

# ICD-11

## International Classification of Diseases for Mortality and Morbidity Statistics

---

Eleventh Revision

---

### Reference Guide



**World Health  
Organization**



## 0 ICD-11 Reference Guide

### 0.1 Copyright page

#### International Classification of Diseases, Eleventh Revision (ICD-11)

##### © World Health Organization 2022

Some rights reserved. This work is available under the Creative Commons Attribution-NoDerivatives 3.0 IGO license (CC BY-ND 3.0 IGO; <https://creativecommons.org/licenses/by-nd/3.0/igo/>).

This license does not allow you to produce adaptations of the work (including translations) without permission from WHO.

Under the terms of this license, you may copy and redistribute the work, provided the work is appropriately cited, as indicated below. In any use of this work, there should be no suggestion that WHO endorses any specific organization, products or services. The use of the WHO logo is not permitted.

Any mediation relating to disputes arising under the license shall be conducted in accordance with the mediation rules of the World Intellectual Property Organization.

This PDF version of ICD-11 was generated to support the user preference for viewing ICD-11 in a portable format. The definitive version of ICD-11 is available from <https://icd.who.int/browse11/l-m/en>.

##### Suggested citation

International Classification of Diseases Eleventh Revision (ICD-11). Geneva: World Health Organization; 2022. License: [CC BY-ND 3.0 IGO](https://creativecommons.org/licenses/by-nd/3.0/igo/).

**Mappings or crosslinks between other classifications and terminologies and ICD-11 and/or translations are not covered by the ICD-11 license and are subject to a separate written agreement from WHO.**

##### Third-party materials

If you wish to reuse material from this work that is attributed to a third party, such as tables, figures or images, it is your responsibility to determine whether permission is needed for that reuse and to obtain permission from the copyright holder. The risk of claims resulting from infringement of any third-party-owned component in the work rests solely with the user.

##### General disclaimers

The designations employed and the presentation of the material in this publication do not imply the expression of any opinion whatsoever on the part of WHO concerning the legal status of any country, territory, city or area or of its authorities, or concerning the

delimitation of its frontiers or boundaries. Dotted and dashed lines on maps represent approximate border lines for which there may not yet be full agreement.

The mention of specific companies or of certain manufacturers' products does not imply that they are endorsed or recommended by WHO in preference to others of a similar nature that are not mentioned. Errors and omissions excepted, the names of proprietary products are distinguished by initial capital letters.

All reasonable precautions have been taken by WHO to verify the information contained in this publication. However, the published material is being distributed without warranty of any kind, either expressed or implied. The responsibility for the interpretation and use of the material lies with the reader. In no event shall WHO be liable for damages arising from its use.

### **Correct use of ICD-11**

Please refer to the reference guide for the correct use of ICD-11 (<https://icdcdn.who.int/icd11referenceguide/en/html/index.html>).

For coding the API must be used. For use of the API or coding tool, (see <https://icd.who.int>).

To prevent the dilution of ICD's purpose to provide a definitive standard for identifying health information, ICD-11 may not be used for the purpose of developing or promoting a different standard.

The use of ICD-11 in software products is subject to the following license: <https://icd.who.int/en/docs/ICD11-license.pdf>. Under the terms of this license, users may not:

- reproduce ICD-11 in part or whole and distribute it under a different name or without attribution;
- reproduce and distribute ICD-11 in part or whole without the ICD-11 codes;
- reproduce ICD-11 in part or whole without the ICD-11 URIs (not applicable for print publications).

**Mappings or crosslinks between other classifications and terminologies and ICD-11 and/or translations are not covered by the ICD-11 license and are subject to a separate written agreement from WHO.**

Adding data fields to ICD-11 concepts is permitted, provided such additions are clearly identified as additions that do not originate from WHO.

Suggestions for changes to ICD-11 should be submitted as a proposal to the ICD-11 maintenance platform (<https://icd.who.int/en>).

## [0 ICD-11 Reference Guide](#)

### [0.1 Copyright page](#)

### [0.2 How to use this Reference Guide](#)

### [0.3 Table of Acronyms and Abbreviations](#)

## [0.4 Glossary](#)

### [1 Part 1 - An Introduction to ICD-11](#)

#### [1.1 International Classification of Diseases \(ICD\)](#)

##### [1.1.1 Intended uses](#)

##### [1.1.2 Classification](#)

##### [1.1.3 ICD in the context of the WHO Family of International Classifications \(WHO-FIC\)](#)

##### [1.1.4 WHO-FIC: Reference Classifications](#)

###### [1.1.4.1 International Classification of Functioning, Disability & Health \(ICF\)](#)

###### [1.1.4.2 The International Classification of Health Interventions \(ICHI\)](#)

###### [1.1.4.3 WHO-FIC: Derived classifications](#)

###### [1.1.4.4 Related classifications](#)

##### [1.1.5 ICD use in health information systems](#)

###### [1.1.5.1 Use of ICD–11 in a digital setting and with web services](#)

###### [1.1.5.2 Use of ICD–11 in an analogue paper-based setting](#)

###### [1.1.5.3 Electronic version](#)

##### [1.1.6 Links with other Classifications and Terminologies](#)

###### [1.1.6.1 Integrated use with Terminologies](#)

###### [1.1.6.2 Functioning in ICD and joint use with ICF overview](#)

#### [1.2 Structure and taxonomy of the ICD](#)

##### [1.2.1 Taxonomy](#)

###### [1.2.1.1 Content model and definition of disease](#)

##### [1.2.2 ICD Chapter structure](#)

##### [1.2.3 Guiding principles for classification of special concepts](#)

##### [1.2.4 General features of ICD-11](#)

###### [1.2.4.1 Code structure](#)

###### [1.2.4.2 Uniform resource identifiers](#)

###### [1.2.4.3 Block codes](#)

###### [1.2.4.4 Stem codes](#)

###### [1.2.4.5 Extension codes and postcoordination](#)

[1.2.4.6 Other general features](#)

[1.2.5 Foundation Component and Tabular lists of ICD–11](#)

[1.2.5.1 Precoordination and Postcoordination in ICD-11](#)

[1.2.5.2 Multiple parenting](#)

[1.2.6 Language independent ICD entities](#)

[1.3 Main uses of the ICD: Mortality](#)

[1.3.1 What is coded: Causes of death](#)

[1.4 Main uses of the ICD: Morbidity](#)

[1.4.1 What is coded: patient conditions](#)

[1.5 Traditional Medicine](#)

[1.6 ICD maintenance](#)

[1.6.1 Guiding principles of authoring process](#)

[1.6.2 Improving user guidance](#)

[1.6.3 Introduction to the ICD–11 Update Process](#)

[1.6.4 National Modifications for morbidity coding](#)

[2 Part 2 - Using ICD-11](#)

[2.1 Basic coding and reporting guidelines](#)

[2.2 Tabular List, Special Tabulation Lists, Qualifiers, and Modifiers](#)

[2.3 Index](#)

[2.4 Reference Guide](#)

[2.5 Browser and coding tool](#)

[2.6 Coding step by step – clinical term](#)

[2.7 ICD–11 conventions](#)

[2.7.1 Inclusions](#)

[2.7.2 Exclusions](#)

[2.7.2.1 ‘Code also’ and ‘Use additional code, if desired’ instructions](#)

[2.7.3 ‘NEC’ and ‘NOS’](#)

[2.7.3.1 ‘NEC’](#)

[2.7.3.2 ‘NOS’](#)

[2.7.4 'Certain'](#)

[2.7.5 Residual categories – 'Other' and 'Unspecified'](#)

[2.7.6 Use of 'And' and 'Or'](#)

[2.7.7 'Due to' and 'Associated with'](#)

[2.7.8 Spelling, parentheses, grammar and other conventions](#)

[2.7.9 General features](#)

[2.8 Stem codes](#)

[2.9 Extension codes](#)

[2.10 Precoordination and postcoordination](#)

[2.10.1 Adding detail – postcoordination and cluster coding with multiple stem codes and extension codes](#)

[2.10.2 Combining stem codes and extension codes, and how to order these in a complex code cluster](#)

[2.10.3 Diagnosis Timing - 'Present on admission' vs. 'Developed after admission'](#)

[2.11 Functioning section](#)

[2.11.1 Functioning assessment](#)

[2.11.1.1 WHO DAS 2.0: features and use cases](#)

[2.11.1.2 WHO DAS 2.0: representation and coding structure](#)

[2.11.2 Generic functioning entity](#)

[2.11.2.1 Functioning entities: features and use cases](#)

[2.11.2.2 Functioning entity: representation and coding structure](#)

[2.12 Electronic recording and reporting](#)

[2.13 Foundation Component and Tabular lists](#)

[2.14 Main uses of the ICD: Mortality](#)

[2.15 Mortality statistics](#)

[2.15.1 What is tabulated: Underlying cause of death](#)

[2.15.2 Data source: The international form of Medical Certificate of Cause of Death \(MCCD\)](#)

[2.15.3 Routine use and special cases](#)

[2.15.3.1 Routine cause of death reporting systems](#)

[2.15.3.2 Verbal autopsy](#)

## [2.16 Basic concepts](#)

### [2.16.1 Terminal cause of death](#)

### [2.16.2 Causal relationship and sequence](#)

### [2.16.3 Starting point](#)

### [2.16.4 Duration](#)

### [2.16.5 First-mentioned sequence](#)

### [2.16.6 Underlying cause of death \(UCOD\)](#)

### [2.16.7 Priority underlying condition](#)

### [2.16.8 Modification](#)

## [2.17 Coding instructions for mortality](#)

### [2.17.1 Basic coding and multiple cause coding guidelines](#)

### [2.17.2 Selecting the underlying cause of death](#)

### [2.17.3 Find the starting point \(Steps SP1 to SP8\)](#)

### [2.17.4 Step SP1 – Single cause on certificate](#)

### [2.17.5 Step SP2 – First condition on the only line used](#)

### [2.17.6 Step SP3 – First condition on the lowest used line causing all entries above](#)

### [2.17.7 Step SP4 – Starting point of the first-mentioned sequence](#)

### [2.17.8 Step SP5 – Terminal cause of death when no sequence](#)

### [2.17.9 Step SP6 – Obvious cause](#)

### [2.17.10 Step SP7 – Ill-defined conditions](#)

### [2.17.11 Step SP8 – Conditions unlikely to cause death](#)

## [2.18 Check for modifications of the starting point \(Steps M1 to M4\)](#)

### [2.18.1 Step M1 – Special instructions](#)

### [2.18.2 Step M2 – Specificity](#)

### [2.18.3 Step M3 – Recheck Steps SP6, M1 and M2](#)

### [2.18.4 Step M4 - Instructions on medical procedures, main injury, poisoning, and maternal deaths](#)

## [2.19 Special instructions on selecting the underlying cause of death](#)

### [2.19.1 Special instructions on accepted and rejected sequences \(Steps SP3 and SP4\)](#)

#### [2.19.1.1 Conflicting durations](#)



[2.19.1.2 Infectious diseases due to other conditions](#)

[Cholera and certain infectious diseases due to other conditions](#)

[Typhoid and certain infectious disease due to other conditions](#)

[HIV due to other conditions](#)

[Infectious diseases not listed above due to other conditions](#)

[2.19.1.3 Malignant neoplasms due to other conditions](#)

[2.19.1.4 Congenital or constitutional haemorrhagic condition due to other conditions](#)

[2.19.1.5 Anaphylaxis due to external causes](#)

[2.19.1.6 Diabetes due to other conditions](#)

[2.19.1.7 Rheumatic fever due to other conditions](#)

[2.19.1.8 Hypertension due to other conditions](#)

[2.19.1.9 Certain ischaemic heart disease due to other conditions](#)

[2.19.1.10 Atherosclerosis due to other conditions](#)

[2.19.1.11 Developmental anomalies due to other conditions](#)

[2.19.1.12 Unintentional cause of morbidity or mortality due to other conditions](#)

[2.19.1.13 Suicide due to other conditions](#)

[2.19.1.14 Obstetric conditions due to other conditions](#)

[2.19.2 Special instructions on obvious cause \(Step SP6\)](#)

[2.19.2.1 Complications of HIV](#)

[Infectious diseases and HIV](#)

[Malignant neoplasms and HIV](#)

[Immune deficiency and HIV](#)

[Pneumonia and HIV](#)

[Cachexia and HIV](#)

[2.19.2.2 Enterocolitis due to Clostridium difficile](#)

[2.19.2.3 Sepsis](#)

[2.19.2.4 Complications of diabetes](#)

[2.19.2.5 Dehydration](#)

[2.19.2.6 Dementia](#)

[2.19.2.7 Disorders of intellectual development](#)

[2.19.2.8 Heart failure and unspecified heart disease](#)

[2.19.2.9 Embolism](#)

[2.19.2.10 Oesophageal varices](#)

[2.19.2.11 Pneumonia](#)

[2.19.2.12 Pulmonary oedema](#)

[2.19.2.13 Nephritic syndrome](#)

[2.19.2.14 Pyelonephritis](#)

[2.19.2.15 Acute renal failure](#)

[2.19.2.16 Primary atelectasis of newborn](#)

[2.19.2.17 Premature rupture of membranes and oligohydramnios](#)

[2.19.2.18 Haemorrhage](#)

[2.19.2.19 Aspiration and inhalation](#)

[2.19.2.20 Surgery and other invasive medical procedures](#)

[2.19.2.21 Common secondary conditions](#)

[2.19.2.22 Secondary peritonitis](#)

[2.19.3 Special instructions on linkages and other provisions \(Step M1\)](#)

[2.19.3.1 Special instructions on Chapter 01 Certain infectious or parasitic diseases](#)

**[Human immunodeficiency virus disease](#)**

[2.19.3.2 Special instructions on Chapter 02 Neoplasms](#)

[2.19.3.3 Special instructions on Chapter 03 Diseases of the blood or blood-forming organs](#)

[2.19.3.4 Special instructions on Chapter 04 Diseases of the immune system](#)

[2.19.3.5 Special instructions on Chapter 05 Endocrine, nutritional or metabolic diseases](#)

[2.19.3.6 Special instructions on Chapter 06 Mental, behavioural or neurodevelopmental disorders](#)

[2.19.3.7 Special instructions on Chapter 07 Sleep-wake disorders](#)

[2.19.3.8 Special instructions on Chapter 08 Diseases of the nervous system](#)

[2.19.3.9 Special instructions on Chapter 09 Diseases of the visual system](#)

[2.19.3.10 Special instructions on Chapter 10 Diseases of the ear or mastoid process](#)

[2.19.3.11 Special instructions on Chapter 11 Diseases of the circulatory system](#)

- [2.19.3.12 Special instructions on Chapter 12 Diseases of the respiratory system](#)
- [2.19.3.13 Special instructions on Chapter 13 Diseases of the digestive system](#)
- [2.19.3.14 Special instructions on Chapter 14 Diseases of the skin](#)
- [2.19.3.15 Special instructions on Chapter 15 Diseases of the musculoskeletal system or connective tissue](#)
- [2.19.3.16 Special instructions on Chapter 16 Diseases of the genitourinary system](#)
- [2.19.3.17 Special instructions on Chapter 17 Conditions related to sexual health](#)
- [2.19.3.18 Special instructions on Chapter 18 Pregnancy, childbirth or the puerperium](#)
- [2.19.3.19 Special instructions on Chapter 19 Certain conditions originating in the perinatal period](#)
- [2.19.3.20 Special instructions on Chapter 20 Developmental anomalies](#)
- [2.19.3.21 Special instructions on Chapter 21 Symptoms, signs or clinical findings, not elsewhere classified](#)
- [2.19.3.22 Special instructions on Chapter 22 Injury, poisoning or certain other consequences of external causes](#)
- [2.19.3.23 Special instructions on Chapter 23 External causes of morbidity or mortality](#)
- [2.19.3.24 Codes not to be used for underlying cause of death](#)
- [2.19.3.25 Codes not to be used if the underlying cause is known or other specific conditions apply](#)
- [2.19.4 Special instructions on surgery and other medical procedures \(Step M4\)](#)
  - [2.19.4.1 Reason for the surgery or procedure stated](#)
  - [2.19.4.2 Reason for the surgery or procedure not stated, complication reported](#)
  - [2.19.4.3 Reason for the surgery or procedure not stated, no complication reported](#)
  - [2.19.4.4 Medical devices associated with adverse incidents due to external causes](#)
- [2.19.5 Special instructions on main injury in deaths from external causes \(Step M4\)](#)
- [2.19.6 Special instructions on poisoning by drugs, medications and biological substances \(Step M4\)](#)
  - [2.19.6.1 The drug most likely to have caused death is specified](#)
  - [2.19.6.2 The drug most likely to have caused death is not specified](#)
  - [2.19.6.3 Identification of the drug most likely to have caused death](#)
- [2.19.7 Special instructions on maternal mortality \(Step M4\)](#)
- [2.20 Coding instructions for mortality: multiple cause coding and other specific instructions](#)

## 2.21 Mortality Rules – Knowledgebase

### 2.21.1 Uncertain diagnosis

#### 2.21.1.1 Either ... or

#### 2.21.1.2 One condition, either one site or another

#### 2.21.1.3 One site or system, either one condition or another condition

#### 2.21.1.4 Either one condition or another, different anatomical systems

#### 2.21.1.5 Either disease or injury

### 2.21.2 Effect of connecting terms

#### 2.21.2.1 Connecting terms implying a causal relationship

#### 'Due to' written or implied by a similar term

#### 'Resulting in' written or implied by a similar term

#### 2.21.2.2 Connecting terms not implying a causal relationship

#### 'And' written or implied by a similar term first or last on a line

#### 'And' written or implied by a similar term but not first or last on a line

#### Diagnostic terms that do not stop at the end of the line

### 2.21.3 Duration of conditions

#### 2.21.3.1 Single duration stated for multiple conditions

#### 2.21.3.2 Modifying temporality of conditions by stated duration

### 2.21.4 'Code also' instructions in mortality use case

### 2.21.5 Malignant neoplasms

#### **Using the coding tool for neoplasms**

#### 2.21.5.1 Behaviour: malignant, in situ, benign, uncertain or unknown behaviour

#### The term itself indicates behaviour

#### Other information on the certificate indicates behaviour

#### 2.21.5.2 Malignant neoplasms: primary or secondary?

#### **Common sites of metastases**

#### **Malignant neoplasm reported as primary**

#### **Other indication of primary malignant neoplasm**

#### **Malignant neoplasm reported as secondary**

[Other indication of secondary malignant neoplasm](#)

[2.21.5.3 More than one primary malignant neoplasm](#)

[2.21.5.4 Site not clearly indicated](#)

[2.21.5.5 Primary site unknown](#)

[2.21.5.6 'Metastatic' cancer](#)

[Malignant neoplasm 'metastatic from' a specified site](#)

[Malignant neoplasm 'metastatic to' a specified site](#)

[Malignant neoplasm metastatic of site A to site B](#)

['Metastatic' neoplasm of a specific histopathology](#)

['Metastatic' malignant neoplasm on the list of common sites of metastases](#)

['Metastatic' malignant neoplasm not on the list of common sites of metastases](#)

['Metastatic' malignant neoplasm, some on the list of common sites of metastases and some not](#)

[2.21.6 Sequelae](#)

[2.21.6.1 Conditions considered to be sequelae](#)

[2.21.6.2 Sequelae of tuberculosis](#)

[2.21.6.3 Sequelae of trachoma](#)

[2.21.6.4 Sequelae of viral encephalitis, diphtheria or other specified infectious diseases](#)

[2.21.6.5 Sequelae of malnutrition or certain specified nutritional deficiencies](#)

[2.21.6.6 Late effects of Chapter 22 and Chapter 23](#)

[2.21.6.7 Sequelae of leprosy](#)

[2.21.6.8 Sequelae of poliomyelitis](#)

[2.21.7 Consistency between sex of patient and diagnosis](#)

[2.21.8 Specific instructions on other ICD categories](#)

[2.21.8.1 Acute or chronic rheumatic heart diseases](#)

[2.21.8.2 Obstetric death of unspecified cause, Obstetric deaths 42 days–1 year after delivery, sequelae of obstetric causes](#)

[2.21.8.3 Deaths due to Certain conditions originating in the perinatal period](#)

[Fetus or newborn affected by maternal factors or by complications of pregnancy, labour or delivery](#)

[2.21.8.4 Special instructions on fetal deaths](#)

[2.21.8.5 Developmental anomalies](#)

[2.21.8.6 Multiple injuries in the same body region and Injuries involving multiple body regions](#)

[2.21.8.7 Complications of surgical and medical care](#)

[2.21.8.8 Intent of external causes](#)

[Undetermined intent](#)

[2.21.8.9 Coding of transport injury events](#)

[2.21.8.10 Factors influencing health status or contact with health services](#)

[2.21.8.11 Infectious agents reported alone on a death certificate](#)

[2.22 Mortality digital end to end solution \(forms, tools and training modules\)](#)

[2.23 Main uses of the ICD: Morbidity](#)

[2.23.1 ICD use in clinical care](#)

[2.23.2 ICD use for epidemiological purposes](#)

[2.23.3 ICD use in quality and patient safety](#)

[2.23.3.1 The quality and safety use case for ICD–11](#)

[2.23.3.2 Reporting on indicators of quality of care and patient safety](#)

[2.23.3.3 Functionality:](#)

[2.23.3.4 Additional information:](#)

[2.23.3.5 Recommendations for use and interpretation of coded data](#)

[2.23.3.6 ICD use for research purposes](#)

[2.23.3.7 ICD use in primary care](#)

[2.23.3.8 ICD use in Casemix groupings](#)

[2.23.4 What is coded: Patient conditions](#)

[2.23.4.1 Main condition](#)

[2.23.4.2 Multiple conditions contributing to need for admission](#)

[2.23.4.3 Other conditions](#)

[2.23.5 Health care practitioner documentation guidelines for morbidity coding](#)

[2.23.5.1 Documentation guidelines involving the term ‘Multiple’-For Single condition reporting](#)

[2.23.5.2 Specificity and detail](#)

- [2.23.5.3 Unconfirmed diagnoses](#)
- [2.23.5.4 Documentation of a ruled out condition](#)
- [2.23.5.5 Contact with health services for reasons other than illness](#)
- [2.23.5.6 Conditions due to external causes](#)
- [2.23.5.7 Documentation of sequelae](#)
- [2.23.6 Coder guidelines for selecting ‘main condition’ and ‘other conditions’ for coding purposes](#)
- [2.23.6.1 MB1 - Several conditions recorded as ‘main condition’](#)
- [2.23.6.2 MB2 - Condition recorded as ‘main condition’ is presenting symptom of diagnosed, treated condition](#)
- [2.23.6.3 MB3 - Signs and symptoms recorded as ‘main condition’ with alternative conditions recorded as the cause](#)
- [2.23.7 Coding using postcoordination in morbidity](#)
- [2.23.7.1 Coder rule for use of extension codes](#)
- [2.23.8 Coding from health care practitioner documentation of ‘causal relationships’](#)
- [2.23.9 Coding of suspected conditions or symptoms, abnormal findings and non-illness situations](#)
- [2.23.10 Coding using combination categories](#)
- [2.23.11 Coding using external causes of morbidity](#)
- [2.23.12 Coding of acute and chronic conditions recorded as main condition](#)
- [2.23.13 Coding of injuries or harm arising from surgical or medical care](#)
- [2.23.14 Coding of adverse events and circumstances in health care that do not cause actual injury or harm](#)
- [2.23.15 Coding of chronic postprocedural conditions](#)
- [2.23.16 Coding ‘History of’ and ‘Family history of’](#)
- [2.23.17 Coding a “ruled out” condition](#)
- [2.23.18 Coding of conditions documented as sequela \(late effect\)](#)
- [2.23.19 Standards and coding instructions for injury events](#)
- [2.23.19.1 Descriptions related to transport injury events](#)
- [2.23.19.2 Classification and coding instructions for unintentional injury caused by transport](#)
- [2.23.20 Conceptual model for quality and patient safety](#)

[2.23.20.1 Overview of code-set in ICD–11 for quality and patient safety](#)

[2.23.20.2 Causation in the context of quality and safety](#)

[2.23.20.3 Chronic postprocedural conditions](#)

[2.23.20.4 Adverse events and circumstances in health care that do not cause actual injury or harm](#)

[2.23.20.5 Recommendations for data capture and organisation](#)

[2.23.21 Chapter-specific notes](#)

[2.23.21.1 Chapter 1: Infectious and parasitic diseases](#)

[2.23.21.2 Chapter 2: Neoplasms](#)

[2.23.21.3 Chapter 3: Diseases of the blood or blood-forming organs](#)

[2.23.21.4 Chapter 5: Endocrine, nutritional or metabolic diseases](#)

[2.23.21.5 Chapter 6: Mental, behavioural or neurodevelopmental disorders](#)

[2.23.21.6 Chapter 8: Diseases of the nervous system](#)

[2.23.21.7 Chapter 9: Diseases of the visual system](#)

[2.23.21.8 Chapter 10: Diseases of the ear or mastoid process](#)

[2.23.21.9 Chapter 11: Diseases of the circulatory system](#)

[2.23.21.10 Chapter 15: Diseases of the musculoskeletal system or connective tissue](#)

[2.23.21.11 Chapter 18: Pregnancy, childbirth or the puerperium](#)

[2.23.21.12 Chapter 21: Symptoms, signs or clinical findings, not elsewhere classified](#)

[2.23.21.13 Chapter 22: Injury, poisoning or certain other consequences of external causes](#)

[2.23.21.14 Chapter 23: External causes of morbidity or mortality](#)

[2.23.21.15 Chapter 24: Factors influencing health status or contact with health services](#)

[2.23.22 Traditional Medicine Conditions - Module 1 \(TM1\)](#)

[2.23.23 Use in Traditional Medicine](#)

[2.23.24 Coding instructions for Traditional Medicine conditions - Module 1 \(TM1\)](#)

[2.24 General statistical recommendations](#)

[2.24.1 Data quality](#)

[2.24.2 Specificity versus ill-defined codes](#)

[2.24.3 Problems of a small population](#)

[2.24.4 'Empty cells' and cells with low frequencies](#)



[2.24.5 Precautions needed when tabulation lists include subtotals](#)

[2.24.6 Ethical Aspects](#)

[2.24.7 Avoidance of Potential Harm](#)

[2.24.8 Security of Privacy – Confidentiality](#)

[2.25 Recommendations in relation to statistical tables for international comparison](#)

[2.25.1 The recommended Special tabulation lists](#)

[2.25.2 International morbidity reporting](#)

[2.25.2.1 Minimum data set and markup for postcoordination](#)

[2.25.3 Presentation of statistical tables](#)

[2.25.3.1 Tabulation of causes of death](#)

[2.25.3.2 Injury mortality](#)

[2.25.4 Standards and reporting requirements for mortality in perinatal and neonatal periods](#)

[2.25.4.1 Terms used in perinatal and neonatal mortality](#)

[2.25.4.2 Definitions in perinatal and neonatal mortality](#)

[Fetal death, spontaneous abortion, stillbirth, live birth, neonatal death](#)

[Artificial termination of pregnancy](#)

[2.25.4.3 Other terminologies used in recording and presentation of perinatal or neonatal mortality](#)

[Fetal death \(i.e. regardless of gestational age; lower limit, if any, should be stated\)](#)

[Stillbirth \(i.e. 22 or more completed weeks\)](#)

[Period of gestation](#)

[Birthweight](#)

[Neonatal death](#)

[Total birth](#)

[2.25.4.4 Certification of stillbirth and live births in the neonatal period](#)

[The international form of medical certificate of cause of death and additional details](#)

[Level of details for recording](#)

[2.25.4.5 Reporting criteria for fetal death, stillbirth and live birth](#)

[Criteria for international reporting](#)

[2.25.4.6 Statistical presentation of perinatal, neonatal, infant or under-five mortality](#)

[Groupings of gestational age groups for fetal death under 22 weeks, stillbirth and neonatal mortality statistics](#)

[Groupings of birthweight for fetal death under 22 weeks, stillbirth and neonatal mortality statistics](#)

[Groupings by chronological age in neonatal mortality statistics](#)

[2.25.4.7 Under-five mortality](#)

[2.25.4.8 Infant mortality](#)

[2.25.5 Standards and reporting requirements related for maternal mortality](#)

[2.25.5.1 Maternal death](#)

[2.25.5.2 Late Maternal death](#)

[2.25.5.3 Comprehensive maternal death](#)

[2.25.5.4 Direct and indirect obstetric deaths](#)

[2.25.5.5 Death occurring during pregnancy, childbirth and puerperium](#)

[2.25.5.6 Recording requirements of maternal mortality](#)

[2.25.5.7 International reporting of maternal mortality](#)

[2.25.5.8 Numerator, denominator, and ratios of published maternal mortality](#)

[3 Part 3 - New in ICD-11](#)

[3.1 ICD-11 new conventions and terminology](#)

[3.1.1 Short Description](#)

[3.1.2 Additional Information](#)

[3.1.3 Code Structure](#)

[3.2 Chapter Structure of ICD-11](#)

[3.2.1 Chapter 01 – Certain infectious or parasitic diseases](#)

[3.2.1.1 Chapter 01 – Structure of chapter 01](#)

[3.2.1.2 Chapter 01 – Rationale for chapter 01](#)

[3.2.1.3 Antimicrobial resistance](#)

[3.2.2 Chapter 02 – Neoplasms](#)

[3.2.2.1 Chapter 02 – Structure of chapter 02](#)

[3.2.2.2 Chapter 02 - Rationale for Chapter 02](#)

[3.2.3 Chapter 03 – Diseases of the blood or blood-forming organs](#)

- [3.2.3.1 Chapter 03 – Structure of chapter 03](#)
- [3.2.3.2 Chapter 03 – Rationale for chapter 03](#)
- [3.2.4 Chapter 04 – Diseases of the immune system](#)
- [3.2.4.1 Chapter 04 – Structure of chapter 04](#)
- [3.2.4.2 Chapter 04 – Rationale for chapter 04](#)
- [3.2.5 Chapter 05 – Endocrine, nutritional or metabolic diseases](#)
- [3.2.5.1 Chapter 05 – Structure of Chapter 05](#)
- [3.2.5.2 Chapter 05 – Rationale for Chapter 05](#)
- [3.2.6 Chapter 06 – Mental, behavioural or neurodevelopmental disorders](#)
- [3.2.6.1 Chapter 06 – Structure of Chapter 06](#)
- [3.2.6.2 Chapter 06 – Rationale for Chapter 06](#)
- [3.2.7 Chapter 07 – Sleep–wake disorders](#)
- [3.2.7.1 Chapter 07 – Structure of Chapter 07](#)
- [3.2.7.2 Chapter 07 – Rationale for Chapter 07](#)
- [3.2.8 Chapter 08 – Diseases of the nervous system](#)
- [3.2.8.1 Chapter 08 – Structure of Chapter 08](#)
- [3.2.8.2 Chapter 08 – Rationale for Chapter 08](#)
- [3.2.9 Chapter 09 – Diseases of the visual system](#)
- [3.2.9.1 Chapter 09 – Structure of Chapter 09](#)
- [3.2.10 Chapter 10 - Diseases of the ear or mastoid process](#)
- [3.2.10.1 Chapter 10 – Structure of Chapter 10](#)
- [3.2.11 Chapter 11 – Diseases of the circulatory system](#)
- [3.2.11.1 Chapter 11 – Structure of Chapter 11](#)
- [3.2.11.2 Chapter 11 – Rationale for Chapter 11](#)
- [3.2.12 Chapter 12 – Diseases of the respiratory system](#)
- [3.2.12.1 Chapter 12 – Structure of Chapter 12](#)
- [3.2.12.2 Chapter 12 – Rationale for Chapter 12](#)
- [3.2.13 Chapter 13 – Diseases of the digestive system](#)
- [3.2.13.1 Chapter 13 – Structure of Chapter 13](#)

[3.2.13.2 Chapter 13 – Rationale for Chapter 13](#)

[3.2.14 Chapter 14 – Diseases of the skin](#)

[3.2.14.1 Chapter 14 – Structure of Chapter 14](#)

[3.2.14.2 Chapter 14 – Rationale for Chapter 14](#)

[3.2.15 Chapter 15 – Diseases of the musculoskeletal system or connective tissue](#)

[3.2.15.1 Chapter 15 – Structure of Chapter 15](#)

[3.2.15.2 Chapter 15 – Rationale for Chapter 15](#)

[3.2.16 Chapter 16 – Diseases of the genitourinary system](#)

[3.2.16.1 Chapter 16 – Structure of Chapter 16](#)

[3.2.16.2 Chapter 16 – Rationale for chapter 16](#)

[3.2.17 Chapter 17 – Conditions related to sexual health](#)

[3.2.17.1 Chapter 17 – Structure of Chapter 17](#)

[3.2.17.2 Chapter 17 – Rationale for Chapter 17](#)

[3.2.18 Chapter 18 – Pregnancy, childbirth or the puerperium](#)

[3.2.18.1 Chapter 18 – Structure of Chapter 18](#)

[3.2.18.2 Chapter 18 – Rationale for Chapter 18](#)

[3.2.19 Chapter 19 – Certain conditions originating in the perinatal period](#)

[3.2.19.1 Chapter 19 – Structure of Chapter 19](#)

[3.2.20 Chapter 20 – Developmental anomalies](#)

[3.2.20.1 Chapter 20 – Structure of Chapter 20](#)

[3.2.20.2 Chapter 20 – Rationale for Chapter 20](#)

[3.2.21 Chapter 21 – Symptoms, signs or clinical findings, not elsewhere classified](#)

[3.2.21.1 Chapter 21 – Structure of Chapter 21](#)

[3.2.21.2 Chapter 21 – Rationale for Chapter 21](#)

[3.2.22 Chapter 22 – Injury, poisoning or certain other consequences of external causes](#)

[3.2.22.1 Chapter 22 – Structure of Chapter 22](#)

[3.2.22.2 Chapter 22 – Rationale for Chapter 22](#)

[3.2.23 Chapter 23 – External causes of morbidity or mortality](#)

[3.2.23.1 Chapter 23 – Structure of Chapter 23](#)

[3.2.23.2 Chapter 23 – Rationale for Chapter 23](#)

[3.2.24 Chapter 24 – Factors influencing health status or contact with health services](#)

[3.2.24.1 Chapter 24 – Structure of Chapter 24](#)

[3.2.24.2 Chapter 24 – Rationale for Chapter 24](#)

[3.2.25 Chapter 25 – Codes for special purposes](#)

[3.2.25.1 Chapter 25 – Structure of Chapter 25](#)

[3.2.26 Chapter 26 - Supplementary Chapter Traditional Medicine Conditions - Module 1](#)

[3.2.27 Section V – Supplementary section for functioning assessment](#)

[3.2.28 Chapter X - Extension Codes](#)

[3.3 Multiple Parenting](#)

[3.4 The Content Model](#)

[3.5 Language independent ICD entities](#)

[3.6 Innovation to mortality coding in ICD-11](#)

[3.7 Innovation to morbidity coding in ICD-11](#)

[3.8 Functioning section](#)

[3.9 General features of ICD–11](#)

[3.10 Traditional Medicine conditions - Module 1 \(TM1\)](#)

[3.11 Preparations for the Eleventh Revision](#)

[3.12 Annex A: ICD-11 Updating and Maintenance](#)

[3.12.1 Background](#)

[3.12.2 Updating Cycle](#)

[3.12.2.1 Types of proposals for ICD-11-MMS maintenance](#)

[3.12.3 Proposal completeness](#)

[3.12.4 Proposal Timelines](#)

[3.12.5 Proposal Workflow](#)

[3.12.6 Changes that cannot be done during the normal updating process](#)

[3.12.7 Applicability and Intellectual Property](#)

[3.13 Annex B: History of the development of the ICD](#)

[3.13.1 Early history](#)

- [3.13.2 Adoption of the International List of Causes of Death](#)
- [3.13.3 The Fifth Decennial Revision Conference](#)
  - [3.13.3.1 International Lists of Diseases](#)
  - [3.13.4 Previous classifications of diseases for morbidity statistics](#)
  - [3.13.5 United States Committee on Joint Causes of Death](#)
  - [3.13.6 Sixth Revision of the International Lists](#)
  - [3.13.7 The Seventh and Eighth Revisions](#)
  - [3.13.8 The Ninth Revision](#)
  - [3.13.9 The Tenth Revision](#)
  - [3.13.10 The WHO Family of International Classifications](#)
  - [3.13.11 Updating of ICD between revisions](#)
  - [3.13.12 Major Steps in the ICD-11 Revision](#)
  - [3.13.13 Preparations for the Eleventh Revision](#)
  - [3.13.14 References for history of ICD](#)
- [3.14 Annex C: Annexes for Mortality Coding](#)
  - [3.14.1 International form of medical certificate of cause of death](#)
  - [3.14.2 Quick reference guide for the International form of medical certificate of cause of death \(MCCD flyer\)](#)
  - [3.14.3 Suggested additional details of perinatal deaths](#)
  - [3.14.4 Workflow diagram for mortality coding](#)
  - [3.14.5 Priority ranking of Nature-of-Injury codes](#)
  - [3.14.6 List of ill-defined conditions](#)
  - [3.14.7 List of conditions that can cause HIV disease](#)
  - [3.14.8 List of conditions that can cause diabetes mellitus](#)
  - [3.14.9 List of conditions to be considered obvious consequences of surgery and other invasive medical procedures](#)
    - [3.14.9.1 List of conditions to be considered direct consequences of surgery](#)
    - [3.14.9.2 List of conditions to be considered direct consequences of other invasive medical procedures](#)
  - [3.14.10 List of conditions unlikely to cause death](#)
  - [3.14.11 List of categories limited to, or more likely to occur in, female persons](#)

- [3.14.12 List of categories limited to, or more likely to occur in, male persons](#)
- [3.14.13 Collection of instructions with coding examples related maternal mortality](#)
- [3.14.14 Target list of causes of death for verbal autopsy](#)
- [3.15 Annex D: Differences between ICD-10 and ICD-11](#)
  - [3.15.1 Chapter 01 – Differences between ICD–10 and ICD–11 in Chapter 01](#)
  - [3.15.2 Differences between ICD–10 and ICD–11 in Chapter 02](#)
  - [3.15.3 Differences between ICD–10 and ICD–11 in Chapter 03](#)
  - [3.15.4 Differences between ICD–10 and ICD–11 in Chapter 04](#)
  - [3.15.5 Differences between ICD–10 and ICD–11 in Chapter 05](#)
  - [3.15.6 Differences between ICD–10 and ICD–11 in Chapter 06](#)
  - [3.15.7 Chapter 07 is a new addition to ICD–11 and was not found in past editions](#)
  - [3.15.8 Differences between ICD–10 and ICD–11 in Chapter 08](#)
  - [3.15.9 Differences between ICD–10 and ICD–11 in Chapter 09](#)
  - [3.15.10 Differences between ICD–10 and ICD–11 in Chapter 10](#)
  - [3.15.11 Differences between ICD–10 and ICD–11 in Chapter 11](#)
  - [3.15.12 Differences between ICD–10 and ICD–11 in Chapter 12](#)
  - [3.15.13 Differences between ICD–10 and ICD–11 in Chapter 13](#)
  - [3.15.14 Differences between ICD–10 and ICD–11 in Chapter 14](#)
  - [3.15.15 Differences between ICD–10 and ICD–11 in Chapter 15](#)
  - [3.15.16 Differences between ICD–10 and ICD–11 in Chapter 16](#)
  - [3.15.17 Chapter 17 is a new addition to ICD–11 and was not found in past editions](#)
  - [3.15.18 Differences between ICD–10 and ICD–11 in Chapter 18](#)
  - [3.15.19 Differences between ICD–10 and ICD–11 in Chapter 19](#)
  - [3.15.20 Differences between ICD–10 and ICD–11 in Chapter 20](#)
  - [3.15.21 Differences between ICD–10 and ICD–11 in Chapter 21](#)
  - [3.15.22 Differences between ICD–10 and ICD–11 in Chapter 22](#)
  - [3.15.23 Differences between ICD–10 and ICD–11 in Chapter 23](#)
  - [3.15.24 Differences between ICD–10 and ICD–11 in Chapter 24](#)
  - [3.15.25 Differences between ICD–10 and ICD–11 in Chapter 25](#)

### [3.16 Annex E: Referred Value Sets](#)

#### 0.2 How to use this Reference Guide

This Reference Guide for ICD-11 is divided into three parts. While each part will contain information valuable for your understanding and use of ICD-11, each has been created to be relevant to your primary purpose for coming to the Guide.

If you are looking to gain a **general, broad understanding of ICD-11**, with little or no prior experience with ICD, we suggest you start with **Part 1**.

If you are looking to **understand how codes are created**, and the details of the organisation behind ICD-11, we suggest you start with **Part 2**.

If you are already familiar with ICD, particularly if you have used ICD-10, we suggest you start with **Part 3** to see **what is new (and what has not changed) in ICD-11**.



### 0.3 Table of Acronyms and Abbreviations

<b>Acronym</b>	<b>In Full</b>
AMR	Antimicrobial Resistance
ATC/DDD	The Anatomical Therapeutic Chemical Classification with Defined Daily Doses
DRG	Diagnostic Related Group
DSAP	Duration Stated, developed After Procedure
DSM-(5 or V)	Diagnostic and Statistical Manual of Mental Disorders (fifth edition)
ICD	The International Classification of Diseases and Related Health Problems
ICD-O	The International Classification of Disease for Oncology
ICECI	The International Classification of External Causes of Injury
ICF	The International Classification of Functioning, Disability, and Health
ICHI	The International Classification of Health Interventions
ICNP	The International Classification of Nursing Practice
ICPC	The International Classification of Primary Care
INN	International Non-proprietary Names
ISO9999	International Standards Organization for Technical aids for persons with disabilities
MMS	Mortality and Morbidity Statistics
NEC	in an ICD category, indicates Not Elsewhere Classified
NOS	in an ICD category, indicates Not Otherwise Specified
OCPR	Other Cause of Procedure Required
PCL	Primary Care Low Resources Settings
SMoL	Startup Mortality List
TAG	Topic Advisory Group
TM	Traditional Medicine
URI	Uniform Resource Identifier
WHODAS	The World Health Organization Disability Assessment Scale
WHO-FIC	The World Health Organization - Family of International Classifications
WM	Western Medicine
WONCA	World Organization of National Colleges, Academies, and Academic Associations of General Practice/Family Practitioners

### 0.4 Glossary

<b>Term</b>	<b>Description</b>
<b>Activity limitations</b>	The level of functioning an individual may have in executing activities.
<b>Body functions</b>	The physiological functions of body systems (including psychological functions).
<b>Body structures</b>	The anatomical parts of the body such as organs, limbs, and their components.
<b>Casemix</b>	A system that groups patients using information about the patient, their diagnoses, procedures, complexity, and needs. Used for resource allocation.
<b>Causal relationship (coding)</b>	A relationship that exists if a condition is caused by another condition (e.g. on the same death certificate or in a morbidity coding situation where one condition or factor causes another condition).
<b>Classification</b>	An exhaustive set of mutually exclusive categories to aggregate data at a pre-prescribed level of specialisation for a specific purpose.
<b>Cluster</b>	A cluster are postcoordinated entities that are joined using either a forward slash (/) or ampersand (&).
<b>Content Model</b>	A structured framework that captures the knowledge that underpins the definition of an entity.
<b>Derived classification</b>	Classifications, often tailored for use at the national or international level, or for use in a specialty, based upon reference classifications.
<b>Dual coding</b>	The process used in situations where clinical terms are coded in to two different classification systems or versions for purposes of comparison, transition, mapping, casemix grouping or understanding the implications of change from one system to another.
<b>Duration (coding)</b>	The time-period between the onset of the disease and the time admission for care or death.
<b>Environmental factors</b>	The physical, social, and attitudinal environment in which people live and conduct their lives.
<b>Extension code</b>	Extension codes are lists of additional information that can be added to a stem code when users and settings are interested in reporting more detail. Extension codes are not mutually exclusive and should not be used alone in the context of statistical classification but must be added to a stem code. Extension codes may be used alone in another context, e.g. for device documentation. Not all extension codes can be used with every stem code. Extension codes can never appear in the first position in a cluster.

<b>Term</b>	<b>Description</b>
<b>Foundation Component</b>	A large collection of terms and their relationships, which describe health and health-related domains. Underlying data base content that holds all necessary information to generate print versions of the Tabular list and the alphabetical index as well as additional information that is needed to generate specialty linearisations of ICD-11 and country specific modifications. The mention of a term or entity in the foundation exclusively serves ontological purposes and indexing. Mention of a term or entity in the foundation does not mean approval or endorsement of a particular condition.
<b>Impairments</b>	The problems in body function or structure such as a significant deviation or loss.
<b>Integrated coding</b>	Full use of all chapters of ICD-11 (including, codes from Western Medicine and Traditional Medicine (TM1) chapters) for classification of clinical terms.
<b>Modification rule</b>	When coding for mortality from death certificates, the procedure by which an ICD code for the starting point is replaced by another code, due to special instructions.
<b>Precoordination</b>	Stem codes which contain all pertinent information about a documented clinical concept in a pre-combined fashion.
<b>Postcoordination</b>	The use of multiple codes (i.e. stem codes and/or extension codes) together to fully describe a documented clinical concept. Postcoordination is permitted by a matter of principle with all codes, as long as at least one stem code is used.
<b>Primary parent</b>	A higher level entity that covers the full range or scope of another entity.
<b>Reference classifications</b>	Classifications that cover the main parameters of the health system – disease (ICD), disability, functioning, and health (ICF), and health interventions (ICHI).
<b>Secondary parents</b>	The ability to connect a specific entity within the classification to more than one parent.
<b>Sequence (coding)</b>	In the context of mortality coding, a set of conditions reported line by line with a causal relationship between each element.
<b>Starting point (coding)</b>	In the context of mortality coding, normally the condition or event reported that started the sequence of acceptable causal relationships ending with the terminal cause of death, or when a death certificate is correctly completed, the condition reported on the lowest used line in Part 1 of the death certificate.
<b>Stem code</b>	Codes in the Tabular list of ICD-11 that can be used alone. Stem codes may be entities or groupings of high relevance in any of the use cases or clinical conditions that should always be described as one single category. Stem codes are designed to ensure that in use cases that require only one code per case, meaningful information is collected.

<b>Term</b>	<b>Description</b>
<b>Terminal cause of death (coding)</b>	The first condition entered on the first used line of Part 1 of the death certificate. Also known as immediate cause of death.
<b>Underlying cause of death</b>	The disease or injury which initiated the train of morbid events leading directly to death, or the circumstances of the unintentional injury or violence which produced the fatal injury.
<b>Verbal autopsy</b>	A method used to ascertain the cause of a death based on an interview with next of kin or other caregivers where no physician can evaluate the deceased.

## 1 Part 1 - An Introduction to ICD-11

### 1.1 International Classification of Diseases (ICD)

The International Classification of Diseases and Related Health Problems (ICD) is a tool for recording, reporting and grouping conditions and factors that influence health. It contains categories for diseases and disorders, health related conditions, external causes of illness or death, anatomy, sites, activities, medicines, vaccines and more.

The purpose of the ICD is to allow the systematic recording, analysis, interpretation and comparison of mortality and morbidity data collected in different countries or regions and at different times.

ICD-11 has been designed to serve semantic interoperability of individual data, reusability of recorded data, for use cases other than health statistics, including decision support, resource allocation, reimbursement, guidelines and more.

The role of the WHO in maintenance and implementation support of ICD is described in the WHO constitution. In addition, implementation and use of the most recent revision of ICD in all member states are legally mandated by the WHO International Nomenclature Regulations and reiterated with revisions of ICD adopted by the World Health Assembly. This includes an updating mechanism between revisions and the ongoing development and implementation of the family of diseases- and health-related classifications (WHO-FIC). The ICD as the core classification linked to other related classifications, specialty versions and terminologies.

In health information systems, data needs to be reusable for epidemiological analysis, resource allocation or research, as well as for individual level uses like health documentation, decision support, or reimbursement. ICD provides highly detailed information, far beyond the level of statistical categories, using unique identifiers. This way for example rare diseases, special findings or individual medicines can be recorded and reported.

The ICD is used to translate diagnoses of diseases and other health problems into alphanumeric codes, allowing storage, retrieval, and analysis of the data. The ICD is the international standard diagnostic classification for all general epidemiological and many health management purposes. These purposes include analysis of general health situations in population groups, monitoring of incidence and prevalence of diseases, and examining

other health problems in relation to other variables, such as the characteristics and circumstances of the affected individuals. ICD is also suitable for studies of financial aspects of a health system, such as billing or resource allocation.

The ICD has evolved over the past 150 years from an International List of Causes of Death to a comprehensive classification and terminology system. The ontology-based design of ICD-11 and the migration of its sibling classifications ICF and ICHI to the same ontological infrastructure has enabled the full integration of terminology and classification in a common platform. In that way lossless clinical documentation is possible (coding all the necessary details), statistical aggregation is an integrated feature, end-to-end digital solutions are provided and links to other terminologies for other uses are enabled.

The ICD is used to allocate the majority of global health resources. Users of the ICD include physicians, nurses, other health care providers, researchers, health information management professionals, coders, health information technology workers, analysts, policymakers, insurers, patient organisations, and many more.

The ICD is used in various settings at different levels of detail. It therefore includes an information framework that contains a fully specified set of health concepts and their characteristics and relationships from which appropriate code sets can be selected. The ICD11 ensures consistency with traditional use cases of earlier ICD versions, because it has been built with the past revisions in mind. Past data analyses based on older versions of ICD can be linked to analyses of data based on ICD11.

The ICD can therefore be used to record, classify and use otherwise data recorded under headings such as cause of death, diagnosis, reason for admission, conditions treated, additional diagnoses, risk factors and reason for consultation, which appear on a wide variety of health records and documents from which statistics are derived.

### 1.1.1 Intended uses

The ICD has been designed to address the needs of a broad range of use cases, such as: causes of death, morbidity, epidemiology, casemix (Diagnosis-Related Groups (DRG)), quality and patient safety, primary care, functioning assessment, research, prevention, substance (medication) or device safety, specific surveillance like antimicrobial resistance (AMR), cancer registration, injury research, as well as ensuring semantic interoperability for clinical documentation, decision support and guidelines or recommendations.

Detailed information and instructions for users on the different use cases are available in other sections of the guide, relating to mortality use and different morbidity uses. Where innovative uses of ICD are envisaged, it is recommended to consult with the WHO to make best use of the flexibility and features of ICD-11.

### 1.1.2 Classification

A classification is 'an exhaustive set of mutually exclusive categories to aggregate data at a pre-prescribed level of specialisation for a specific purpose' (ISO 17115). A classification involves the categorisation of relevant concepts for the purposes of systematic recording or analysis. The categorisation is based on one or more logical rules. The purpose of a health classification varies. For example, it may be used in the analysis of cause of death

(mortality), morbidity, or human functioning. Low frequency concepts tend to be grouped but rare concepts may be individually classified.

Coding is the process of assigning a code from a classification to represent a clinical concept for a specific purpose. Coding rules must be incorporated in the classification to achieve consistency of coding and comparability of coded data over time and place. Classifications are complementary to terminologies, since they are designed to be used for standardised coding of information for statistical purposes.

ICD-11 is combining the elements of classification and terminology and is designed to be linked to other terminologies that may provide additional detail or serve different purposes. Coding in ICD-11 can draw on statistical codes and on Uniform Resource Identifiers (URIs).

### 1.1.3 ICD in the context of the WHO Family of International Classifications (WHO-FIC)

The WHO Family of International Classifications (WHO-FIC) comprises classifications that have been endorsed by the WHO to describe various aspects of health and the health system in a consistent manner.

The WHO-FIC provides standardised building blocks for health information systems and consists of three broad groups: Reference classifications, Derived classifications, and Related classifications.

The Reference and the Derived classifications are based on the Foundation Component, which is a large collection of concepts (with synonyms and preferred terms) and their relationships, which describe health and health-related domains.

Terms and entities related to diseases and health-related problems are organised into the ICD, those pertaining to functioning into the ICF, and those related to interventions into ICHI (International Classification of Health Interventions). Terms from the Foundation Component may be used in more than one Reference classification.

Derived Classifications draw on terms that may come from one or more of the Reference Classifications. Within the WHO-FIC Family, Related classifications are regarded as complementary to the Reference and Derived classifications. Related classifications have their own sets of terms, but can also share terms as part of the WHO-FIC Family.

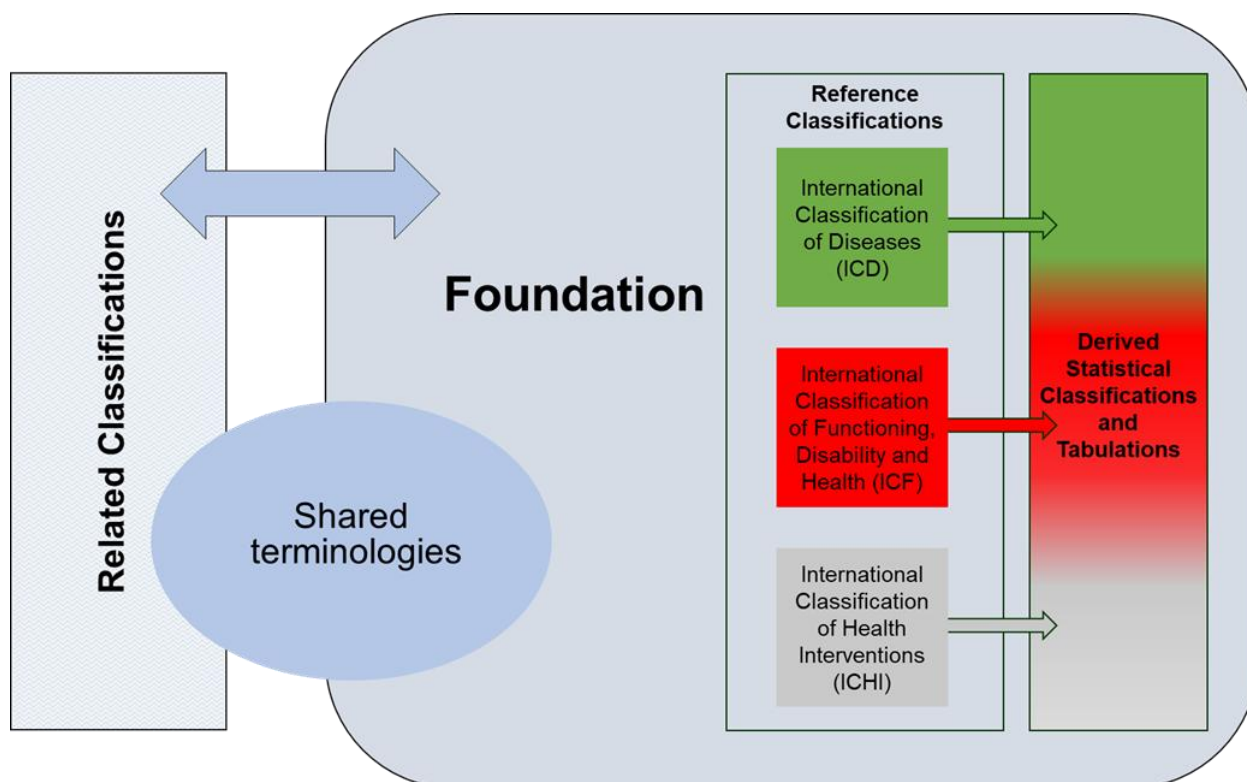

**Figure 1:** Relationships between the WHO Family of International Classifications (WHO-FIC) and Related Classifications, the Foundation Component, and shared terms.

The purpose of the WHO-FIC is to assist the development of reliable statistical and other data systems at local, national, and international levels, with the aim of improving health status and health care. Health related information might sometimes require additional detail to that contained in the ICD. A group or ‘family’ of health relevant classifications covers these needs both by classification of domains different from those of the ICD and provision of more details for specific uses, e.g. cancer registration. The WHO-FIC designates a suite of integrated classification products that share similar features and can be used singularly or jointly to provide information on different aspects of health and health care systems. For example, the ICD as a reference classification is mainly used to capture mortality and morbidity information. Functioning is classified in the International Classification of Functioning, Disability and Health (ICF) and health interventions in the International Classification of Health Interventions (ICHI).

The WHO-FIC provides a conceptual framework of information dimensions which are related to health and health management. In this way, it provides a common language that improves communication and permits comparisons of data within countries, across countries, health care disciplines, services, and time. The WHO and the WHO-FIC Network (including collaborating centres, Non-governmental Organisations (NGOs), and selected experts) (<https://www.who.int/standards/classifications/who-fic-maintenance>) (<https://www.who.int/standards/classifications/who-fic-maintenance>) strive to build the Family of International Classifications based on sound scientific and taxonomic principles, ensure that it is up-to-date, culturally appropriate and internationally applicable, and meet the needs of its different users by focusing on the multi-dimensional aspects of health.

### 1.1.4 WHO-FIC: Reference Classifications

Reference classifications cover the main parameters of the health system, such as death and disease (ICD), disability, functioning, and health (ICF) and health interventions (ICHI). WHO-FIC reference classifications are a product of international agreements. They have achieved broad acceptance and official agreement for use and are approved and recommended as standards for international reporting on health. They may be used as models for the development or revision of other classifications. The three Reference classifications are:

1. International Classification of Diseases and Health Related Problems (ICD)
2. International Classification of Functioning, Disability & Health (ICF)
3. International Classification Health Interventions (ICHI)

The Reference Classifications are based on the same Foundation Component and share sets of Extension Codes.

#### 1.1.4.1 International Classification of Functioning, Disability & Health (ICF)

The ICF is the WHO's framework for measuring health and functioning/disability at both the individual and population levels. While the ICD classifies diseases and causes of death, the ICF classifies health and health-related domains. ICD and ICF together provide a framework to capture the full picture of health.

The ICF classifies health and health-related states in two parts. Part one deals with functioning and disability, described from the perspectives of the body, the individual, and society. It is composed of two components: Body functions and structures, and Activities and participation. Part two covers contextual factors and also has two components: Environmental factors and Personal factors, since an individual's functioning occurs in a context. Work is proceeding on the development of a classification of personal factors to be included in the contextual factors.

Functioning is a generic term for body functions (e.g. memory), body structures (e.g. occipital lobe), and activities and participation (e.g. walking, engaging in paid work). It denotes the positive aspects of the interaction between an individual (related to the individual's health) and that individual's contextual factors (environmental and personal factors).

Disability is an umbrella term for impairments, activity limitations and participation restrictions. It denotes the negative aspects of the interaction between an individual (with a health condition) and that individual's contextual factors (environmental and personal factors). Disabilities are envisioned as a continuum and therefore the ICF and the codes within it do not confer an international binary status of disabled/not disabled. Levels of disability can be used descriptively in clinical settings when formulating a case. Program and policy decision-makers can apply the ICF and specify their own standards for the level of disability as eligibility criteria that are relevant for specific purposes.

ICF includes other relevant descriptions:



- *Body functions* are the physiological functions of body systems (including mental functions).
- *Body structures* are anatomical parts of the body such as organs, limbs and their components.
- *Impairments* are problems in body function or structure such as a significant deviation or loss.
- *Activity* is the execution of a task or action by an individual.
- *Activity limitations* are difficulties an individual may have in executing activities.
- *Participation* is involvement in a life situation.
- *Participation restrictions* are problems an individual may experience in involvement in life situations.
- *Environmental factors* make up the physical, social and attitudinal environment in which people live and conduct their lives.

ICF includes codes for Body Functions (b), Body Structures (s), Activities and Participation (d), and Environmental Factors (e).

ICF codes are only complete with the presence of a qualifier, which denotes the level of health (i.e. severity of the problem from ‘no problem’ to ‘complete problem’). Without qualifiers, codes have no inherent meaning. The ICF acknowledges that every human being can experience a decrement in health and thereby experience some disability. Disabilities can be temporary and may be brief (such as staying home from work for a few days with the flu); they can also be chronic or permanent and may fluctuate in severity over time.

Personal factors are included in the ICF model of functioning and disability, but have not been classified in ICF because of the large social and cultural variants associated with them. The taxonomy has not been operationalized further due to challenges related to establishing cross-cultural applicability, resource constraints, and ethical considerations.

#### **1.1.4.2 The International Classification of Health Interventions (ICHI)**

ICHI includes interventions across all functional sectors of the health system, covering acute care, primary care, rehabilitation, assistance with functioning, prevention, public health, and ancillary services. Interventions delivered by all types of providers have been included. The importance of describing and classifying health interventions has long been understood. An International Classification of Procedures in Medicine (ICPM) was published by WHO in 1978 but was not maintained. ICHI is much broader than the former ICPM because it includes the full range of health interventions. Development of ICHI began in 2007, as a joint effort of the WHO Family of International Classifications (WHO-FIC) Network and WHO, based on the experience gathered with the development of several national classifications of health interventions.

**Table 1:** *Descriptions and terms used in creation of ICHI.*

<b>Axes</b>	<b>Inclusions</b>	<b>Example</b>
The <b>Target axis</b> contains the entities on which the action is carried out.	Anatomy, Human function, Person or client, Group or population	stomach, activities of daily living
The <b>Action axis</b> is defined as a deed which is done by an actor to a target during a health care intervention.	Investigation, Treating, Managing, Informing, Assisting, Preventing	biopsy, vaccination
The <b>Means axis</b> contains the entities describing the processes and methods by which the action is carried out.	<b>Approach:</b> the process by which the target of the action is accessed	open, endoscopic
	<b>Technique</b> used as part of the action	radiation, magnetic resonance
	<b>Method</b> describing how the action is undertaken	law enforcement, method of transport.

The content of the axes has been restricted to attributes that are common to many interventions. In particular:

- Devices have not been included as an axis because most interventions do not involve a device and devices change rapidly, however devices may be included as extension codes
- Drugs or other substances administered through an intervention are classified elsewhere (e.g. ICD, The Anatomical Therapeutic Chemical Classification with Defined Daily Doses (ATC/DDD), INN).

The coding system comprises a seven-character category structure for the three axes:

- Three letters for the Target
- Two letters for the Action
- Two letters for the Means

ICHI codes comprise valid seven letter combinations of the three axes. For each intervention included in ICHI, the appropriate seven letter combination is identified. Not every possible combination of the three axes represents a valid ICHI domain.

### 1.1.4.3 WHO-FIC: Derived classifications

Derived classifications are often tailored for use at the national or international level or for use in a particular specialty. They are based on reference classifications (i.e. ICD, ICF, ICHI). Derived classifications may be prepared by:

- adopting the reference classification structure and classes
- providing additional detail beyond that provided by the reference classification
- rearrangement or by aggregation of items from one or more reference classifications.

ICD-11 has specialty linearisations that are derived from the common foundation. These include a version for dermatology, one for primary care and one for mental health. Others may follow.

#### 1.1.4.4 Related classifications

Related classifications are included in the WHO Family of International Classifications to describe important aspects of health or the health system not covered by reference or derived classifications. Related classifications are:

- International Classification of Primary Care (ICPC)
- International Classification of External Causes of Injury (ICECI)
- Technical aids for persons with disabilities (ISO9999)
- The Anatomical Therapeutic Chemical Classification with Defined Daily Doses (ATC/DDD)
- The International Classification for Nursing Practice (ICNP)

#### 1.1.5 ICD use in health information systems

Health information systems include a range of different components for collection, analysis, and use of health data. Information sources could, for example, be population-based, health facility-based, or focused on particular diseases. The main population-based sources of health information are civil registration and vital statistics (CRVS) systems, census data, and household surveys.

Health facility-related data sources include public health surveillance, health services data (that may be referred to as health management information systems or routine health information systems (RHIS)), and health system monitoring data (e.g. human resources, health infrastructure, financing).

National health accounts (NHA) are designed to provide a comprehensive picture of health financing. Coding enables the recording of health information in a language independent way. Standardisation of coding enables both intra- and international data comparison. For example, ICD coded data can be compared across different sectors of the health system – if the same coding rules are applied.

Health information systems are increasingly based on digital (electronic) reporting and coding. ICD-11 is designed to be used in such environments. The content of this Reference Guide is the only additional document required when coding with ICD-11.

In many places information collection is based on paper reporting in a traditional analogue way. ICD-11 can also be produced in a printed version for use in paper-based systems if needed (see [1.1.5.2](#)).

### 1.1.5.1 Use of ICD-11 in a digital setting and with web services

ICD-11 is used for coding of diagnoses, in electronic health records or with electronic death certificates, or in other digital data collections. Special tools like the ICD-11 Coding Tool facilitate finding specific ICD-11 codes for any of the several dimensions that define an ICD-11 entity or category. Additional details can be added using multiple codes for one condition. Retaining the unique identifier of the coded ICD-11 entity allows the same information to be reused across different translations. WHO has developed ICD web services (<https://icd.who.int/icdapi>); designed to support interoperable machine-to-machine interaction.

### 1.1.5.2 Use of ICD-11 in an analogue paper-based setting

ICD-11 can be used as an analogue printed version, if needed. Information is reported on hard copy documents and then coded manually with the ICD-11. It should be noted that paper-based recording requires manual transcription of the information into electronic systems and consideration should be given to moving to electronic reporting as early as possible in the information chain. Paper-based recording may cause problems with readability and timeliness of coded data. ICD-11 supports many ways of computer assisted coding including embedding of instructions for code combinations and other possible plausibility checks. The long-term goal for all users should be coding using ICD-11 in an electronic environment.

In the print version, the information is divided into 3 volumes, the Tabular list, the Reference Guide, and the Index. All three are needed to use the ICD correctly.

### 1.1.5.3 Electronic version

In the browser version of the ICD, most information is interlinked and visible in the relevant context. The WHO provides this version for browsing ICD-11 in multiple languages (linked from <https://icd.who.int>). This tool allows the user to retrieve concepts by searching for terms, anatomy or any other element of the content model. With the browser, users can also contribute to the updating and continuous improvement of ICD with comments and suggestions. Such input is reviewed for consideration for inclusion on an annual basis.

ICD-11 can also be accessed using web services with user specific software. The IT guide to the ICD provides more details on compatibility requirements can be found on the following page: <https://icd.who.int/icdapi>. Both the web services and the online browser allow access and searching of all Tabular lists of the ICD, including for mortality and morbidity statistics, primary care, or for specialty linearisations for certain specific domains.

## 1.1.6 Links with other Classifications and Terminologies

ICD coded entities or categories can be used in conjunction with other relevant health classifications and terminologies to fully document an episode of care, or a case for research.

### 1.1.6.1 Integrated use with Terminologies

Classification involves grouping information according to logical rules. Terminology allows the reporting of information at any desired level of detail: for example, body parts, findings,

or other elements that constitute a disease. Only items defined in a terminology can be reported (i.e. terminologies have no mechanism to report new information that has not previously been added to the terminology). In contrast, a classification has residual classes ('other specified' and 'unspecified') that ensure that all cases can always be classified. In a terminology, similar to a modern classification, a disease can be defined, for example by establishing linkages between its elements, such as anatomy or findings. Terminologies retain the information without emphasising any aspect of the recorded information.

In contrast, classifications allow for identification of 'relevant parts' of the content, for example, for public health purposes. International agreement about these relevant parts ensures sure that the aggregated information is internationally comparable. The standardised use of the aggregation logic of a classification and the standardised use of the detailed information of a terminology aim at the same result: comparability. Transparent international agreement processes are necessary in both cases, with integration of index and tabular lists, ICD has moved towards having its own terminology component.

Terminologies and classifications should be considered complementary. ICD-11 Foundation is the terminological part of ICD-11 derived from the former ICD-10 Index and other sources. Third party terminologies ideally are linked to the ICD-11 Foundation in 1:1 relationships or "signposted from ICD-11 foundation in 1:n relationships. These links shall follow the recommendations by the mapping paper.

#### **1.1.6.2 Functioning in ICD and joint use with ICF overview**

Historically, the ICD has used certain disability concepts as common disease or disorder entities, such as: blindness, deafness, learning disability, or paraplegia, as well as certain disability concepts for other purposes, such as 'disability as a sequela of injury', and 'limitation of activities due to disability'. The ICF was developed after the publication of ICD-10.

In ICD-11, links with ICF have been created in terms of aligning the concepts of disease and functioning and facilitating the joint use.

Conceptual alignment between ICD-11 and ICF has taken place in several areas.

- Signs and symptoms in the ICD are aligned with body functions in the ICF, and 'factors influencing health status' in the ICD align with contextual factors in the ICF.
- ICD-11 categories related to visual impairment in the Ophthalmology Chapter (Chapter 09) have been aligned with the respective ICF taxonomy and definitions for seeing functions.

Additional selected ICF categories are drawn from the component Activities and Participation and help to describe the functional limitations commonly associated with specific health conditions in a functioning pattern. The impact of a disease or disorder in the daily activities of a person may vary depending on the severity of the condition as well as the contextual factors (e.g. environmental factors) and possible co-morbidities. The ICD takes an approach that identifies 'severity' as a property of the disease/disorder and describes the impact of the health condition on the daily life of a person with a set of functioning codes.

An optional functioning section has been embedded in ICD-11 to enable the classification and measurement of the impact of health conditions in terms of functioning.

The ICD-11 functioning section provides two options for impact assessment and documentation:

- use of an ICF-based generic assessment instrument (i.e. World Health Organization Disability Assessment Schedule (WHODAS) 2.0) and the Model Disability Survey (MDS) to generate an overall and domain specific functioning score. In order to obtain such scores, WHODAS 2.0 (like other clinical rating scales) has to be used as a whole (i.e. the full battery of questions). Further instructions on the use of WHODAS 2.0 are provided in the WHODAS Manual.
- use of a short-list of functioning categories derived from ICF Annex 9. These categories should be used with a generic 5-point qualifier indicating severity for reporting of functioning in health information systems.

Overall, the linkage between ICD-11 and ICF may assist with the following use cases:

- evaluation for general medical practice (e.g. work in capacity assessment)
- evaluation for social benefits (e.g. disability pension)
- payment or reimbursement purposes
- needs assessments (e.g. for rehabilitation, occupational assistance, long-term care)
- outcome evaluation of interventions

Wherever full *functioning* reporting is desired and required, the ICF should be used. (see Section 2.11 for further information)

## 1.2 Structure and taxonomy of the ICD

The chapter and block structure of the ICD has evolved in 11 iterations of the classification over 150 years. The authoring of ICD follows a set of rules that ensure the functional and structural integrity of the classification. The evolution of the ICD carefully balances the need for categories that match current knowledge while allowing statistical comparability over space and time.

The chapter structure of ICD reflects major aspects of diseases. Chapters are not intended to delimit areas of medical expertise or domains of specialties. The link to any specialty or reimbursement schemes is secondary. The ICD has categories for diseases, disorders, syndromes, signs, symptoms, findings, injuries, external causes of morbidity and mortality, factors influencing health status, reasons for encounter of the health system, and traditional medicine. ICD-11 complements these by allowing capture of additional details such as anatomy, substances, medications, medical devices, infectious agents, place of injury, and many more. ICD-11 also comes with a set of rules and explanations for its use and necessary metadata. Required reporting formats are also included.

The most widespread use of ICD over time and geographically is for cause of death (mortality) statistics. ICD is also used for classification of clinical documentation, to provide standardised, language independent information for morbidity use, such as resource allocation, casemix, patient safety and quality of care, as well as primary care and research. ICD and its descriptions are also used as a framework in legislation.

### 1.2.1 Taxonomy

A statistical classification of diseases must be confined to a limited number of mutually exclusive categories able to encompass the complete range of morbid conditions. The categories are chosen to facilitate the statistical study of disease phenomena. Every disease or morbid condition must have a well-defined place in the list of categories. Consequently, throughout the classification, there are residual categories for other and miscellaneous conditions that do not have their own unique category or which cannot be allocated to the more specific categories. However, the ICD-11 Uniform Resource Identifiers (URI) allow retention of such detail for future analysis. The following measures apply in determining whether an entity qualifies to become a unique category:

1. Epidemiological evidence: frequency analyses of coded mortality and morbidity data
2. Clinical evidence: disease evidence provided by the medical specialties
3. Granularity: minimum detail reported and useful in mortality or primary care
4. Continuity: preservation of the level of detail pre-existing in ICD
5. Parsimony: the need to limit the number of categories for international mandatory reporting

A statistical classification can allow for different levels of detail if it has a hierarchical structure and subdivisions. A statistical classification of diseases should retain the ability to both identify specific disease entities and to allow statistical presentation of data for broader groups, thus enabling the attainment of useful and understandable information. The same general principles apply to the classification of other health problems and reasons for contact with health care services, which are also incorporated in the ICD. The ICD was developed as a practical, rather than a purely theoretical classification, in which there are a number of compromises between classification based on aetiology, anatomical site, circumstances of onset, or other criteria.

ICD-11 draws extensively on the method of combining several codes to describe a clinical condition to the desired level of detail. Its electronic architecture allows assignment of unique identifiers to any condition listed - independently whether the condition is grouped in a statistical class or whether it represents a class of its own. The two approaches together allow the option of keeping coding simple where diagnostic detail is limited; and alternatively adding detail where diagnostic reporting requires a high level of comprehensiveness and sophistication.

#### 1.2.1.1 Content model and definition of disease

##### **Content model**

For further information please see [3.4 The Content Model](#).

##### **Definition of disease**

A disease is usually defined using a set of relevant aspects drawn from the pattern below. A disease is a set of dysfunctions in any body system defined by:

Property	Description
Symptomatology or manifestations	Known pattern of signs, symptoms, and related findings
Aetiology	An underlying explanatory mechanism
Course and outcome	A distinct pattern of development over time
Treatment response	A known pattern of response to interventions
Linkage to genetic factors	E.g. genotypes, patterns of gene expression, etc.
Linkage to environmental factors	Factors of the environment that trigger presence of a disease

### 1.2.2 ICD Chapter structure

The ICD is a variable-axis classification. The structure was developed out of that proposed by William Farr in the early days of international discussions on classification structure: epidemic diseases, constitutional or general diseases, local diseases arranged by site, developmental diseases, injuries.

These groups remain in the chapters of ICD–11. The structure has stood the test of time and, though in some ways arbitrary, is still regarded as more useful for general epidemiological purposes than any of the alternatives tested. The conservation of the structure acknowledges the need for stability while allowing incorporation of additional sections.

Special groups bring together conditions that would be inconveniently arranged for epidemiological study if they were to be scattered, for instance in a classification arranged primarily by anatomical site. **These conditions formulate the ‘special groups’ chapters:**

Chapter	Title
1	Certain infectious or parasitic diseases
2	Neoplasms
3	Diseases of the blood or blood-forming organs
4	Diseases of the immune system
18	Pregnancy, childbirth, or the puerperium
19	Certain conditions originating in the perinatal period
20	Developmental anomalies
22	Injury, poisoning or certain other consequences of external cause

The distinction between the ‘special groups’ chapters and the ‘body systems’ chapters has practical implications for understanding the structure of the classification, for coding to it, and for interpreting statistics based on it. It has to be remembered that, in general, conditions are primarily classified to one of the ‘special groups’ chapters.

Where there is any doubt as to where a condition should be positioned, the ‘special groups’ chapters take priority. This principle is enforced in the ‘excludes’ notes at the beginning of each chapter in the ICD.



### 1.2.3 Guiding principles for classification of special concepts

1. Clinical findings are located in Chapter 21 'Symptoms, signs or clinical findings, not elsewhere classified'. (e.g. 'Abnormal serum enzyme levels' or 'Results of function studies of the circulatory system')
2. Manifestations of diseases, a relevant point for health intervention, are 'clinical manifestations' located in the body system chapter where they manifest. The underlying condition has to be coded as well. (e.g. myocarditis)
3. Syndromes, where the aetiology is unknown, are allocated with the most relevant body system. (e.g. Costen syndrome is in the 'Digestive' chapter)
4. The number of categories with 'due to' in the title are restricted to certain exceptions. (e.g. acute bronchiolitis due to respiratory syncytial virus)
5. Very specific, chronic, postprocedural conditions are grouped at the end of the body system chapter where they manifest. (e.g. lymphoedema due to surgery or radiotherapy). Residual categories do not exist for these groups.
6. Acute postprocedural complications are identified by combinations of codes from body system or injury chapters, and external causes chapter (e.g. an unintentional puncture of an organ during an intervention is classified with a code for the injured organ (harm), a code describing what surgery caused the injury (cause), and a code identifying the unintentional puncture as the mode/mechanism of injury.).
7. Categories with mention of 'multiple' are restricted to exceptions and require coding of the different multiple conditions individually (e.g. multiple injuries are to be coded individually when possible).
8. Categories with mention of 'sequelae' are restricted to exceptions. The specific condition resulting as a sequela needs to be coded along with the underlying cause. In some instances, they will continue to exist with the label 'late effects of...' (e.g. late effects of cerebrovascular disease or late syphilis). 'Sequelae' include residual effects of diseases or disorders, injuries or poisonings specified as such, or as late effect of, arrested, cured, healed, inactive, old or quiescent condition unless there is evidence of active disease.
9. Categories with mention of 'history of' are limited to exceptions (e.g. personal history of malignant neoplasms lists only the more frequent anatomical sites).
10. High level groupings need to be meaningful.
11. Residual categories exist only where they are meaningful. (e.g. where conditions are either congenital or acquired, there is no 'other' residual, but there will be an 'unspecified' option)

### 1.2.4 General features of ICD-11

The main structural innovation of ICD–11 is that it is built on a Foundation Component from which the Tabular lists (such as the classification for morbidity and mortality statistics) are derived.

#### 1.2.4.1 Code structure

The codes of the ICD–11 are alphanumeric and cover the range from 1A00.00 to ZZ9Z.ZZ. These are referred to as stem codes. The structure of stem codes is described below:

- The first character of the code always relates to the chapter number. It may be a number or a letter.
- Codes starting with 'X' indicate an extension code (see [2.9](#)).
- There is always a letter in the second position to differentiate ICD-11 codes from the codes in ICD-10.
- The inclusion of a forced number at the third character position prevents spelling 'undesirable words'.
- The letters 'O' and 'I' are omitted to prevent confusion with the numbers '0' and '1'.

For example, [1A00](#) is a code in Chapter 01, and [BA00](#) is a code in Chapter 11.

For example: ED1E.EE

- E corresponds to a 'base 34 number' (0-9 and A-Z; excluding O, I);
- D corresponds to 'base 24 number' (A-Z; excluding O, I); and
- 1 corresponds to the 'base 10 integers' (0-9)
- The first E starts with '1' and is allocated for the chapter. (i.e. 1 is for the first chapter, 2: chapter 02, ... A chapter 10, etc.)

The terminal letter Y is reserved for the residual category 'other specified' and the terminal letter 'Z' is reserved for the residual category 'unspecified'. For the chapters that have more than 240 blocks, 'F' ('other specified') and 'G' ('unspecified') are also used to indicate residual categories (due to limitations in the coding space).

Throughout the Reference Guide a dash indicates that more detailed codes exist, and should be used as appropriate. For example

- [8B24](#) - covers codes from [8B24.0](#) to [8B24.Z](#)
- [CA23.0](#) - covers [CA23.01](#) to [CA23.02](#)

#### 1.2.4.2 Uniform resource identifiers

All entities have a Uniform Resource Identifier (URI) which is a string of characters that uniquely identifies a particular ICD-11 entity. Each entity has a specific place in the hierarchy of groups and categories.

#### 1.2.4.3 Block codes

Higher level entities in ICD-11 (called 'blocks') may be used for reporting aggregated statistics. However, blocks do not have category codes as they are not supposed to be used in coding. Blocks have their own URIs (e.g. the URI for Neoplasms is <http://id.who.int/icd/entity/1630407678>). Blocks may also be referred to by block IDs. The code structure for block IDs are 11 characters long (e.g. "BlockL1-1A0").

#### 1.2.4.4 Stem codes

Codes in the Tabular list of ICD-11 that can be used alone. Stem codes may be entities or groupings of high relevance in any of the use cases, or clinical conditions that should always be described as one single category. Stem codes are designed to ensure that in use cases that require only one code per case, meaningful information is collected.

#### 1.2.4.5 Extension codes and postcoordination

The extension codes are comprised of groups of codes e.g. anatomy, agent, histopathology and other aspects that may be used to add detail to a stem code. Extension codes are not to be used alone in the context of statistical classification but must be added to a stem code. Extension codes may be used in another context, e.g. for device documentation. Not all extension codes can be used with every stem code. Refer to [2.9](#).

Postcoordination is a notable new feature in ICD-11 that creates the ability to link core diagnostic concepts (i.e. stem+stem code concepts) when desired, and/or to add clinical concepts captured in extension codes to primary stem code concepts. The linked diagnostic concepts are called a cluster. It should be emphasised that the postcoordination ability inherent in ICD-11 is one of the significant changes compared with ICD-10. A cluster describes one clinical concept as described by the health care practitioner. Postcoordination is by matter of principle permitted with all axes, as long as at least one stem code is used. API, Browser and coding tool facilitate postcoordination in certain areas. Other areas of postcoordination have to be coded individually, but may be supported by future updates of ICD-11, where need arises.

#### 1.2.4.6 Other general features

- ICD-11 categories have **short descriptions**, plus long descriptions labelled ‘additional information’. The short description is a maximum of 100 words relating to the entity that states things that are always true about a disease or condition which are necessary to understand the scope of the rubric. It appears in the Tabular list of the classification. The long ‘additional information’ is the full description, without length restriction.
- **Special tabulation lists** (refer to section [2.25](#)) continue to exist in ICD-11, but there are three additional lists - the Startup Mortality List (SMoL), the list for verbal autopsy, and the list for infectious diseases by agent. Specialty linearisations allow the representation of content from the perspective of a specialty, such as dermatology or neurology, through the creation of subsets, and through the precoordination of more detail, if desired.

#### 1.2.5 Foundation Component and Tabular lists of ICD-11

The Foundation Component is a multidimensional collection of all ICD entities. It is an underlying database that holds all necessary information to generate print versions of the tabular list and the alphabetical index, as well as additional information that is needed to generate specialty linearisations of ICD-11 and country-specific modifications. Entities can be diseases, disorders, injuries, external causes, signs and symptoms. Some entities may be very broad, for example ‘injury of the arm’, while others are more detailed, for example ‘laceration of the skin of the thumb’. The Foundation Component also has the necessary information to use the entities to build a tabular list. The Foundation Component includes information on where and how a certain entity is represented in a Tabular list, whether it becomes a grouping, a category with a stem code, or whether it is mentioned as an index term in a particular category.

Several different Tabular lists can be built from the Foundation Component. Drawing on the same Foundation Component, a set of tabular lists that builds on the same hierarchical tree structure can be created – producing congruent tabular lists. The Foundation component includes instructions on how to combine certain codes in a Tabular list to achieve more

detail in coding. These rules help coders and computer systems to visualise the permitted code combinations when they are using a Tabular list.

In a Tabular list, entities of the Foundation Component become categories. The categories are mutually exclusive and jointly exhaustive and linked to a mono hierarchical tree (that is, they have only one parent). The information related to an entity that has become a category and has multiple parents is still available from the Foundation Component. This information can be used to visualise that category in more than one place in the Tabular list, e.g. by showing them in black font in its place for reference tabulation and in grey font in any other place for browsing or alternative tabulations. ICD–11 has multiple congruent tabular lists with varying levels of detail.

### **1.2.5.1 Precoordination and Postcoordination in ICD-11**

A health condition may be described to any level of detail, by applying more than one code, or by ‘postcoordinating’ (i.e. combining):

- two or more stem codes, (e.g. code1/code2)
- stem codes with one or more extension codes. (e.g. stem code&extension code1&extension code2)

In this manner, the classification can address a large number of clinical concepts with a limited range of categories.

Stem codes contain all pertinent information in a pre-combined fashion. This is referred to as ‘precoordination’. When additional detail that pertains to a condition is described by combining multiple codes, this is referred to as ‘postcoordination’. The combination of codes is called a cluster. Refer to [2.10](#).

### **1.2.5.2 Multiple parenting**

An entity may be correctly classified in two different places, e.g. by site or by aetiology. For a disease, such as oesophageal cancer, this would mean that it could be classified to cancers (malignant neoplasms) or to conditions of the digestive system. In the same way, cerebral ischaemic conditions could be classified to the vascular system or to the nervous system. A decision about which place a condition is in depends on international agreement and legacy.

### **1.2.6 Language independent ICD entities**

ICD-11 entities are language independent. The maintenance of the ICD-11 on an international level is handled in the English language but the content model of ICD–11 is language independent and allows binding of any desired language to the elements of its Foundation Component. In this way, an international translation base facilitates translations or multilingual browsing. (See [3.12 Annex A: ICD-11 Updating and Maintenance](#))

## **1.3 Main uses of the ICD: Mortality**

Mortality statistics are widely used for medical research, monitoring of public health, evaluating health interventions, and planning and follow-up of health care. Rules adopted by the World Health Assembly (WHA) regarding the selection of a single cause or condition, from death certificates, for routine tabulation of mortality statistics are provided to

standardise production of mortality data. Implementation of the ICD for mortality requires establishment of an infrastructure for reporting and storing information, design of information flows, quality assurance and feedback, and training for classification users working with the input or output of data.

### 1.3.1 What is coded: Causes of death

The description of a single underlying cause of death, and selected approaches to capture further information on causes of death also reported on a death certificate, enables the identification of trends in health for a given population.

Effective public health interventions prevent harm or death by breaking the chain of events that lead to harm. For this purpose, the underlying cause of death has been defined as ‘(a) the disease or injury which initiated the train of morbid events leading directly to death, or (b) the circumstances of the accident or violence which produced the fatal injury’, and is selected for routine single-cause tabulation of mortality statistics. (See Section [2.20](#) for more information.)

## 1.4 Main uses of the ICD: Morbidity

Morbidity data are used for statistical reporting mostly at national or local levels. While some of this statistical reporting is conducted within an academic research context, it is commonly conducted in applied settings to inform health system and public health agency decision-making. ICD coded data also forms the basis for different casemix systems, such as different varieties of Diagnosis Related Groups (DRGs). Coded morbidity data can also be used to inform a variety of clinical guidelines through provision of Foundation Component information on burden of disease.

### 1.4.1 What is coded: patient conditions

The definition of main condition relates to the description of an episode of hospital-based care. The health care practitioner should record and identify as the main condition the one condition that is determined to be the reason for admission, established at the end of the episode of health care.

The health care practitioner responsible for the patient’s treatment is also responsible for documenting the patient’s health conditions. This information should be organised systematically by using standard recording methods. A properly completed record is essential for good patient management. It is also an essential prerequisite to the creation of a valid coded record of patient diagnoses, derived through a coding process from written information describing the patient’s medical condition. When a sound written record of patient conditions is available, successful coding of this information in ICD and associated classifications produces a valuable source of epidemiological and other statistical data on morbidity and other health care problems. The person transforming the information on the stated condition to codes (the ‘coder’) may be the health care practitioner or a clinical coder (who is not responsible for the patient’s treatment). In the latter situation, which is common among member countries, the coder depends on the adequacy of clinical documentation of patient conditions by health care practitioners in the medical record. The importance of clinical documentation by health care practitioners as the starting point for coded health data cannot be overstated, and needs to be underlined as being a matter of key significance

within countries and internationally. This has implications for education on health information and clinical documentation within health care practitioner training programs. (See Section [1.4](#) for more information.)

## 1.5 Traditional Medicine

Traditional Medicine (TM) is an integral part of health services provided in many countries. International standardisation by including Traditional Medicine within the ICD allows for measuring, counting, comparing, formulating questions and monitoring over time. Although some countries have had national Traditional Medicine classification systems for many years, information from such systems has not been standardised or available globally.

It is recommended that coding of cases with ICD-11's chapter on Traditional Medicine disorders and patterns (TM1) be used in conjunction with the Western Medicine concepts of ICD Chapters 1-25.

As with other ICD chapters, the TM1 chapter is not designed to assess TM practice or the efficacy of any TM intervention. However, as a tool for classifying, diagnosing, counting, communicating and comparing TM conditions, it assists research and evaluation to assess the safety and efficacy of TM.

See [3.12 Annex A: ICD-11 Updating and Maintenance](#) for more detailed information.

## 1.6 ICD maintenance

The ICD maintenance process allows for the updating of the ICD following evolution in the understanding of diseases, treatments, and prevention. It also ensures improvements and clarifications coming from daily use of ICD, and requests by Member States or any other interested party.

A standardised open process has been established to ensure that the proposed updates are collected, routed, reviewed, and duly considered before being implemented. A proposal and review mechanism on an online platform makes the process transparent. Workflows ensure that proposed changes are considered both from a medical and scientific perspective and from their value and place in a particular use case (See [3.12 Annex A: ICD-11 Updating and Maintenance](#)).

### 1.6.1 Guiding principles of authoring process

Allocation of entities in the classification follows a set of rules that serve to maintain the structural and functional integrity of the classification. The core set of rules listed here is complemented by additional rules that address special cases or serve to ensure consistent user guidance. They are listed in order of priority.

1. No changes to the classification, including movement of categories or groups between chapters, without rationale and documented change in aetiology or prevention method. (e.g. Chapter 04 - 'Diseases of the immune system' was added as a new chapter as there was sufficient scientific evidence to support this move). Alternatively, it was suggested to move 'wounds of skin' to 'Diseases of the skin'. The

wound of the skin, being an injury, remains grouped with injuries because prevention will focus on the cause of the wound.

2. Conditions are classified predominantly by their aetiology.
  - Local manifestations of important ‘aetiologies’ are located in the aetiology chapter (e.g. Viral hepatitis is in ‘Certain infectious or parasitic disease’).
  - Where one condition can be due to multiple different aetiologies, and it is more relevant to retain the affected body system, it is usually classified with the body system (e.g. some gastric ulcers are caused by bacteria, but they remain in the ‘Digestive system’ chapter).
  - Where the aetiology of the condition is unknown, it is allocated to the most relevant organ system (e.g. Costen syndrome is in the ‘Digestive system’ chapter).
  - Systemic ‘aetiologies’ are primarily in their relevant aetiology chapter (e.g. Idiopathic inflammatory myopathy is in “Diseases of the immune system”).
3. Conditions that could arguably be in two or more places of the classification remain in their legacy location.
  - For example, injuries of the eye are equally important for the eye and their prevention. Despite the suggestion of including them in the eye chapter, they remained where they were, in the injury chapter.
  - Where aetiology and body system are equally important, the legacy location remains unchanged (e.g. ocular motor nerve palsies).
4. Keeping a group of subtypes together in one location may override anatomical or aetiological considerations (e.g. human prion diseases - some have a genetic component, others a transmissible component).

### 1.6.2 Improving user guidance

The following rules serve to provide user guidance. Users may expect to find conditions in certain places when browsing the tree structure. User groups may need to group data or create subsets for other reasons. The multiple parenting in the Foundation Component serves to address that issue. 1. Where a condition could be in two or more places, identify these other places and add them as secondary parents, e.g. malignant neoplasm of the colon is coded to the neoplasm chapter, but is also shown in the chapter of diseases of the digestive system. In case a set of conditions needs to be shown in more than one place and there is no grouping matching that set, create a window (no primary children, no terms, no residual categories) in the appropriate place. 2. Where a condition could be confused with another condition bearing a similar name, add an exclusion note. (e.g. ‘Influenza due to seasonal influenza virus’ has a note ‘Exclusion: Haemophilus influenzae [H. influenzae] meningitis’). 3. Where alternative ways of tabulating data are required, create a special linearisation list as a second parent (e.g. infectious diseases by agent). The coding scheme of the individual entries will remain the one used for the full international classification. 4. Where diseases of certain body systems are spread across different chapters, allow for a specialty linearisation of the pertinent diseases. The coding scheme of the individual entries will remain the one used for the full international classification. Currently there are specialty linearisations for primary care, dermatology, neurology, ophthalmology, and in special cases

such as the International Classification of Disease for Oncology (ICD-O) and the International Classification of External Causes of Injury (ICECI).

### 1.6.3 Introduction to the ICD-11 Update Process

Official releases of the ICD-11 classification are produced annually for international use in mortality and morbidity (This is known as the 'blue browser'). By contrast, the ICD-11 Foundation Component is continuously updated. A standardised process has been established to ensure that the proposed updates are collected, routed, reviewed, and duly considered before being implemented.

The updating is carried out at different levels with different frequencies. Updates that impact on the four- and five-character codes will be published every five years. Updates at a more detailed level are published more frequently. Additions to the index are done on an ongoing basis. Mortality and morbidity rules that have significant impact on statistical output will be updated in long-term cycles of every 10 years.

Any individual user of the classification can submit a proposal for an update to the ICD. Such updates can refer to one or more entities of the ICD. They may address the position of entities in a tabular list, in the Foundation Component, and any element of the content model. The maintenance platform of ICD-11 (known as the 'orange browser') is used for proposals and comments. Any input to ICD-11 and its components requires proper referencing of sources, details of scientific evidence, and permission from the owner of any copyright materials (where applicable).

### 1.6.4 National Modifications for morbidity coding

The use of ICD in the specific context of the health care system of a country may require detail that is not currently part of ICD-11, for example, due to specific settings or due to reimbursement system requirements. Such changes will be subject to the same international process as are all other changes to ICD and will then become part of the Foundation Component and eventually of the Mortality and Morbidity Statistics (MMS), ideally prior to their implementation in the requesting country.

A situation may arise, where a national government or a related national institution needs a modification to be implemented immediately. In such circumstances, conflicts with the current Foundation Component must be avoided, and the relevant changes will be subject to special mechanisms for the international updating process. All countries planning to produce national modifications must make relevant contractual arrangements with WHO. This includes regulations on distribution within and outside the respective country and the resources necessary for the WHO to add such changes to the foundation.

For developing a national modification of ICD-11 the following rules must be adhered to:

1. Ideally, modifications will be agreed by the ICD-11 maintenance bodies before they are implemented nationally.
2. Modifications should not impact on morbidity and mortality statistics, and should not conflict with the foundation.
3. Approval of all national modifications will be subject to consideration of whether suitable additional detail already exists in the foundation.



4. If a change is made to the international version of ICD-11 the respective national modification must incorporate the change as soon as possible.

### Example

'Diabetes Type 1' in the WHO version of ICD-11 is classified to [5A10](#). A national modification may require additional detail to be added to the ICD-11 codes. For example, 'Diabetes Type 1, uncontrolled' could be added as a subcategory to [5A10](#), as 5A10.1 Diabetes Type 1, uncontrolled. However, when the mechanism of postcoordination provides the necessary detail, the addition of a new subcategory may not be necessary.

## 2 Part 2 - Using ICD-11

### 2.1 Basic coding and reporting guidelines

Coding is the assignment of one or more codes in order to represent the meaning of a condition in as much detail as required. Before attempting to code, the coder should be acquainted with the principles of classification and coding. In some instances, using one code will provide sufficient detail. In other instances, it may be necessary to use several codes together to express the level of detail required by the use case, setting, or laws.

For coding, it is recommended to use the ICD-11 Smart coding tool that can be used online and offline. It provides users with a simple automated way to find and select the needed categories. When the search shows a cluster of codes, rather than a single stem code, the tool can return the assembled cluster.

Software must not include lists or other prompts to guide the recording or coding, as these necessarily limit the range of diagnoses and therefore have an adverse effect on the accuracy and usefulness of the record and report.

There may be an alternative way, to use the print version of ICD-11 but this option is not recommended as its time consuming and may cause confusion in finding and selecting the correct codes or code combinations without the hints that the electronic coding tool provide. In case no electronic environment is available, specific solution can be sought in collaboration with WHO.

### 2.2 Tabular List, Special Tabulation Lists, Qualifiers, and Modifiers

The Tabular list is an alphanumeric listing of diseases and disease groups, inclusion and exclusion notes, and some coding rules. Chapters 1 to 25 of the ICD contain approximately 15 000 entities at the four-, five- or six-character level.

In addition, there is a section on extension codes ([2.9](#)) and one on Traditional medicine ([1.5](#)). The Special tabulation lists are presented at the end of the Tabular list. Special tabulation lists are not designed for coding but are for tabulation and reporting only ([2.25](#)).

### 2.3 Index

The Alphabetical Index is a list of more than 120 000 clinical terms (including synonyms or phrases). The index is used to find the relevant ICD codes or code combinations for clinical

terms. The mention of a term in the index exclusively serves coding. Mention of a term in the index does not mean approval or endorsement of a particular condition.

## 2.4 Reference Guide

The Reference Guide contains an introduction to the context, components, and intended use of the ICD. It describes the diverse components of ICD-11, provides guidance for certification, recording, rules for mortality coding (i.e. causes of death statistics) and morbidity coding (e.g. hospital statistics) and lists for tabulation of statistical data.

## 2.5 Browser and coding tool

The WHO provides a browser and coding tool ('blue browser') for ICD-11 in multiple languages <https://icd.who.int>. This tool allows the user to retrieve concepts by searching for terms, anatomy or any other element found within the content of ICD-11 (see [1.2.5 Foundation Component and Tabular lists of ICD-11](#)).

WHO also provides a maintenance platform ('orange browser'), (see [3.12 Annex A: ICD-11 Updating and Maintenance](#)). This tool allows the users to contribute to the updating and continuous improvement of ICD-11. Such input is submitted in the form of a proposal with a detailed rationale, scientific evidence and peer reviewed references to justify consideration for inclusion on an annual basis (see [3.12 Annex A: ICD-11 Updating and Maintenance](#)).

For coding, the WHO provides the ICD-11 Smart coding tool, a simple automated way to find and select the needed categories.

ICD-11 can also be accessed using web services with user-specific software. The IT guide to the ICD provides more details on compatibility requirements.

Both the web services and the online browser allow access to all Tabular lists of the ICD, for mortality and morbidity statistics, primary care, or for a specialty linearisation for use in certain specialised domains.

## 2.6 Coding step by step – clinical term

The table below compares the coding steps in a paper and an electronic environment. The essential component of coding is finding a match to the reported clinical term – having a good dictionary in the relevant language, and verifying the resulting code against additional rules, are necessary. In an electronic environment programmatically embedded instructions can verify compliance with the coding rules.

### Electronic

1. Enter the statement or term in the coding tool
2. Select the matching term, or the one closest to what you are looking for from amongst the displayed options
3. Verify the result in the tabular list browser view for exclusions, inclusions and notes given at the level of that category, its grouping levels and at the chapter level.

### Paper

1. Look up the lead term in the Alphabetical Index and applicable secondary terms.
2. Select the appropriate term, or one closest to what you are looking for, from amongst the listed options
3. Verify the result in the tabular list (Volume 1) for exclusions, inclusions and notes given at the level of that category, its grouping levels and at the chapter level.

The WHO online browser and coding tool are available at <https://icd.who.int>.

## 2.7 ICD–11 conventions

ICD–11 has standard ways of presenting its content. Conventions describe textual content and also apply to the coding structure.

### 2.7.1 Inclusions

Within the coded categories there are typically other optional diagnostic terms. These are known as ‘inclusion terms’ and are given, in addition to the title, as examples of the diagnostic statements to be classified to that category. They may refer to different conditions or be synonyms. They are not a sub-classification of the category.

Inclusion terms are listed primarily as a guide to the content of the category, in addition to the descriptions. Many of the items listed relate to important or common terms belonging to the category. Others are borderline conditions or sites listed to distinguish the boundary between one subcategory and another. The lists of inclusion terms are by no means exhaustive.

Alternative names of diagnostic entities (synonyms) are included and shown in the electronic coding tool and the Alphabetic Index.

It is sometimes necessary to read inclusion terms in conjunction with titles. This usually occurs when the inclusion terms describe lists of sites or pharmaceutical products, where appropriate words from the title (e.g. ‘malignant neoplasm of ...’, ‘injury to ...’, ‘toxic effects of ...’) need to be understood. General diagnostic descriptions common to a range of categories, or to all the subcategories in a four-character category, are to be found in the notes heading ‘Inclusions’, immediately following a chapter, group, or category title.

### 2.7.2 Exclusions

Certain categories contain lists of conditions preceded by the word ‘Exclusions’. These are terms which are classified elsewhere. An example of this is [5A60](#) *Hyperfunction of pituitary gland* which excludes Cushing syndrome.

Exclusions serve as a cross reference in ICD and help to delineate the boundaries of a category.

General exclusions for a range of categories or for all subcategories are found in the notes heading 'Excludes', immediately following a chapter, group or category title.

Multiple parenting in ICD-11 shows categories in the context of siblings that are placed elsewhere in the classification. This is also an indication of an exclusion and means 'a sibling is coded elsewhere'. In the print and the electronic version this is marked with the label 'code elsewhere'.

### 2.7.2.1 'Code also' and 'Use additional code, if desired' instructions

'Code also' instructions inform the user about required additional aetiological information which is mandatory to be coded in a cluster with certain categories because that additional information is relevant for primary tabulation. The 'code also' statement marks the categories that must be used in conjunction with the indicated second code(s). However, in some instances aetiology may be unknown although the condition requires treatment in its own right. In this circumstance, the code may be reported alone.

For example, the category Diabetic cataract indicates 'code also' type of diabetes. This means that in conjunction with the code for 'diabetic cataract', the code for the type of diabetes should be assigned. Both stem codes for the type of diabetes and the diabetic cataract are always reported in a cluster.

'Use additional code, if desired' - instructions inform the user about optional additional detail that can be coded.

### 2.7.3 'NEC' and 'NOS'

#### 2.7.3.1 'NEC'

The stem 'not elsewhere classified', when used in a category title, serve as a warning that certain specified variants of the listed conditions may appear in other parts of the classification. For example, [NF09](#) Adverse effects, not elsewhere classified. Codes to which the NEC description is appended should only be used if one of the other options available in the classification is not suitable.

#### 2.7.3.2 'NOS'

The letters NOS are an abbreviation for the term 'not otherwise specified', implying that the documentation that is used for classifying does not provide more detail beyond the term provided. It implies 'unspecified', 'incompletely specified' or 'unqualified'. Sometimes an unqualified term is nevertheless classified to a rubric for a more specific type of the condition. This is because, in medical terminology, the most common form of a condition is often known by the generic name of the condition itself and only the less common types are qualified. For example, 'pharyngitis' is commonly used to mean 'acute pharyngitis'. These inbuilt assumptions have been taken into account in order to avoid incorrect classification.

Careful inspection of inclusion terms will reveal where an assumption of cause has been accounted for. Coders should be careful not to code a term as unqualified unless it is quite clear that no information is available that would permit a more specific assignment elsewhere. Similarly, in interpreting statistics based on the ICD, some conditions assigned to an apparently specified category will not have been so specified on the record that was

coded. When comparing trends over time and interpreting statistics, it is important to be aware that assumptions may change from one revision of the ICD to another. For example, before the Eighth Revision, an unqualified aortic aneurysm was assumed to be due to syphilis (this is no longer the case since the introduction of ICD–10). In ICD-11 in most instances the ‘NOS’ terminology points to unspecified categories, so that future data analysis can take care of assumptions regarding the linguistic meaning.

Additional terms permitted in ICD coding:

- Certain
- Other
- Unspecified
- And
- Or
- Due to
- With
- Caused by
- Attributed to
- Secondary to
- Associated with

#### 2.7.4 ‘Certain’

The term ‘certain’ is used where certain entities that could be grouped in a specific location in the classification are grouped somewhere else outside the current chapter or block. For example, [8B22](#) *Certain specified cerebrovascular diseases* means that only some specified cerebrovascular diseases are coded here, whereas other specific types of cerebrovascular disease are located elsewhere in the classification.

#### 2.7.5 Residual categories – ‘Other’ and ‘Unspecified’

ICD-11 coding should always be completed to include the most specific level of detail possible with the use of one code or multiple codes as described above. There are, however, circumstances when that is not possible and for that reason the ICD-11 includes categories titled ‘other’ and ‘unspecified’. In some instances, necessary information to select a specific category may not be available in the source documentation. When this is the case, the residual category ‘unspecified’ is selected. Conversely, there are instances where the information in the source documentation is very specific, but the tabular list does not include a specific category. In this case, users identify the closest category match, and code to the residual category titled ‘other’.

#### 2.7.6 Use of ‘And’ and ‘Or’

The words ‘and’ and ‘or’ in ICD–11 are used in their meaning in formal logic. A term that includes a statement of the kind ‘A and B’ means that both A and B, have to be present in order to use that category. A term that includes a statement of the kind ‘A or B’ means that the category may be used if either A or B are present.

### 2.7.7 'Due to' and 'Associated with'

'Due to' is the preferred term for categories where two conditions are mentioned, and a causal sequence exists between them. Other terms, such as 'caused by' or 'attributed to' are allowable synonyms. The phrase 'secondary to' is equivalent and may also be included as a synonym. 'Associated with' is the preferred term for categories where two conditions are mentioned but there is no causal sequence implied.

### 2.7.8 Spelling, parentheses, grammar and other conventions

Spelling and grammar of ICD-11 follow the British rules with exceptions and amendments conforming to WHO spelling rules. The detailed conventions are listed below. The ICD-11 terminology uses the following conventions:

- Terms are listed in their singular form. For example, 'Superficial injury of scalp' instead of 'Superficial injuries of scalp'. There are exceptions when the singular form doesn't apply, such as 'Multiple injuries of head', and when a term describes a group of diseases, such as "Benign vascular neoplasms".
- No use of apostrophes with eponyms. For example, 'Hodgkin lymphoma' (instead of 'Hodgkin's lymphoma')
- Entities are described using natural language. For example, 'myocardial infarction' (instead of 'infarction, myocardial').
- Abbreviations are printed using upper case letters and followed by the complete title in full. For example, 'MI – [myocardial infarction]'.
- Parentheses are used in the tabular list to enclose the code to which an exclusion term refers. For example, [9A01.3](#) *Infectious blepharitis* Exclusions: Blepharoconjunctivitis ([9A60.4](#))

### 2.7.9 General features

The main structural innovation of ICD-11 is that it is built on a Foundation component from which the tabular lists (such as the classification for morbidity and mortality statistics) is derived. See [1.2.5 Foundation Component and Tabular lists of ICD-11](#).

#### **Table 1: ICD-11 Terminology**

ICD-11 Term	Explanation
Foundation component	Underlying data base content that holds all necessary information to generate print versions of the tabular list and the alphabetical index, as well as additional information that is needed to generate specialty linearisations of ICD-11 and country specific modifications.
Stem code	Stem codes are codes that can be used alone. They are found in the tabular list of ICD-11 for Mortality and Morbidity Statistics. Stem codes may be entities or groupings of high relevance, or clinical conditions that should always be described as one single category. The design of stem codes makes sure that in use cases that require only one code per case, a meaningful minimum of information is collected.
Extension code	Extension codes are lists of additional information that can be added to a stem code when users and settings are interested in reporting more detail. Extension codes are not mutually exclusive. They are not designed to be a classification but may show hierarchies and can never be used without a stem code in the context of statistical classification. Extension codes can never appear in the first position in a cluster. Extension codes may be used alone in another context, e.g. for device documentation.
Precoordination	Stem codes may contain all pertinent information about a clinical concept in a pre-combined fashion. This is referred to as 'precoordination'. <b>Example:</b> <a href="#">BD50.40</a> <i>Abdominal aortic aneurysm with perforation</i> <b>Example:</b> <a href="#">CA40.04</a> <i>Pneumonia due to Mycoplasma pneumoniae</i>
Postcoordination	The use of multiple codes (i.e. stem codes and/or extension codes) together to fully describe a documented clinical concept. Postcoordination is by matter of principle permitted with all axes, as long as at least one stem code is used. API, Browser and coding tool facilitate postcoordination in certain areas. Other areas of postcoordination have to be coded individually, but may be supported by future updates of ICD-11, where need arises.
Cluster	A cluster is the postcoordinated entities that are joined using either a forward slash (/) or ampersand (&). <b>Example:</b> Diagnosis: Duodenal ulcer with acute haemorrhage Cluster: <a href="#">DA63.Z/ME24.90</a> Condition - <a href="#">DA63</a> <i>Duodenal ulcer, unspecified</i> Has manifestation (use additional code, if desired) - <a href="#">ME24.90</a> <i>Acute gastrointestinal bleeding, not elsewhere classified</i>

ICD-11 Term	Explanation
Primary and secondary parents	<p>The hierarchy of ICD-11 is defined the same as it was in previous versions of ICD. The ability to connect specific diseases and concepts within the classification to another parent code was introduced to enable specific extracts of the Tabular list for medical specialties or for specific use cases.</p> <p><b>Example:</b> A code for a malignant neoplasm of the skin is in the chapter for malignant neoplasms. The primary parent for this code is a code or a block from this chapter. However, a medical doctor treating only skin diseases might want to see only codes from the classification that are relevant for his or her specific clinical purpose. Therefore, a secondary parent was defined in the skin chapter which will only show the code in this chapter if the specific extract of codes for his or her use case is selected.</p>

## 2.8 Stem codes

ICD-11 stem codes are codes in a particular tabular list that can be used alone. Stem codes may be entities or groupings of high relevance, or clinical entities that should always be described as one entity. The design of stem codes makes sure that in use cases that require only one code per case a meaningful minimum of information is collected.

The stem codes of the ICD-11 are organised in 26 chapters that follow the traditional pattern of the ICD, relating to aetiology, relevant organ system, maternal status, perinatal status, external causes, and factors influencing health status.

## 2.9 Extension codes

Extension codes are provided for use as supplementary or additional codes when it is desired to identify more detail in classification entities elsewhere. The inclusion of the new Extension codes in ICD-11 provides capacity for coding qualifying information and are linked to stem codes. Extension codes have been designed to standardise the way additional information is added to stem codes, and the adoption of multi-dimensional coding results in a substantially reduced amount of stem codes. Extension codes may be used alone in other contexts, e.g. device documentation.

Extension codes are not mutually exclusive. They are not a classification and can never be used without a stem code for statistical purposes. Extension codes can never appear in the first position in a classification cluster. One or more extension codes can be linked when coding a specific condition.

There are two main types of Extension codes:

- Type 1 extension codes allow the user to add detail to a stem code in terms of severity, temporality, anatomy, histopathology of the condition or other dimensions like substances and medical devices. For example, if the diagnostic statement reads 'cervical disc prolapse C5-C6' the anatomy extension code [XA1X49](#) *Cervical intervertebral disc or space C5-C6* can be added to the stem code [FA80.1](#) *Intervertebral disc degeneration of cervical spine with prolapsed disc* in order to capture the detail of contained in the diagnostic statement.



- Type 2 extension codes represent diagnosis code descriptors which indicate how the diagnosis is to be used and/or interpreted. The meaning of the code refers to the same condition, but the use of type 2 – diagnosis code descriptor extension code alters its interpretation. For example, for adverse event reporting it is important to code diagnosis timing in terms of [XY6M](#) *Present on admission*, [XY69](#) *Developed after admission*, or [XY85](#) *Uncertain timing of onset relative to admission*.

### Overview of the Type 1 Extension codes

- Severity scale value
- Temporality (course of the condition)
- Aetiology
- Topology Scale Value
- Anatomy and topography
- Histopathology
- Dimensions of injury
- Dimensions of external causes
- Consciousness
- Substances
- ICD-O
- Health Devices, Equipment and Supplies

### Overview of Type 2 – Extension codes - Diagnosis Code Descriptors

- Discharge diagnosis types
- Diagnosis timing
- Diagnosis timing in relation to surgical procedure
- Diagnosis method of confirmation
- Diagnosis certainty
- Obstetrical diagnosis timing
- Encounter descriptors
- Capacity or context

## 2.10 Precoordination and postcoordination

Some stem codes contain all pertinent information about a clinical concept in a pre-combined fashion. This is referred to as ‘precoordination’.

A health condition may be further described to any level of detail, by applying more than one code, or by ‘postcoordinating’ (i.e. combining codes):

- two or more stem codes, (i.e. code1/code2)
- stem codes with one or more extension codes. (i.e. stem code&extension code1&extension code2)

A group of codes that have been postcoordinated is called a ‘cluster’. A forward slash (/) or ampersand (&) is used to show the linkage between postcoordinated codes. In this manner, the classification can address many clinical concepts with a limited range of categories.

## Example

Precoordination of concepts in a single code Condition: [2C25.2 Squamous cell carcinoma of bronchus or lung](#) has precoordination, both site and pathology are combined in a single precoordinated stem code.

## Example

Postcoordination of concepts combined in a cluster: the condition urinary tract infection due to Extended spectrum beta-lactamase producing Escherichia coli' is expressed through a combination of two linked or postcoordinated stem codes. Condition: [GC08.0 Urinary tract infection, site not specified, due to Escherichia coli](#) Associated with (use additional code, if desired): [MG50.27 Extended spectrum beta-lactamase producing Escherichia coli](#) Cluster code: [GC08.0/MG50.27](#)

### Postcoordination axis

'Has causing condition' - this field is indicating the causing condition that must be coded when known. The causing condition can be compared to the 'dagger' code in ICD-10. This option is found at entities that are typically caused by a range of different conditions and is referred to as mandatory postcoordination in the Coding tool.

'Has manifestation' - prompts the user to code any manifestations. Manifestations can be compared to the 'asterisk' codes in ICD-10. This option is found at entities that can develop manifestations.

'Associated with' - when conditions are captured together for a full picture but do not necessarily represent a cause and effect scenario.

### Description

It is mandatory to code the causing condition for primary tabulation when it is known. 'Has causing condition' is added to categories that are caused by an underlying disease. For example, retinopathy has a 'causing condition' of diabetes. Causing conditions should be considered required in almost all situations, and must be used for conditions that are manifestations.

It is optional to code manifestations of a disease. For example, diabetes 'Has manifestations' such as retinopathy. This coding should be considered 'Allowed' in almost all situations. The listed manifestations are usually a sample of the ones frequently resulting from the condition.

This field is used when multiple codes are required to fully describe a condition. For example, 'Associated with' is used to link the codes for antimicrobial resistance to the codes for the infection. This coding can be either 'Allowed' or 'Required' depending on the situation.

Special cases for postcoordination:

1. External cause codes are 'allowed' to identify the cause of an injury and are 'associated with' the injuries.
2. The external cause code to identify a specific drug is 'allowed' with entities beginning with or including the phrase 'Drug -induced'.
3. External cause codes for the mode and mechanism of health care related harm are 'associated with' the codes for the harm.

### 2.10.1 Adding detail – postcoordination and cluster coding with multiple stem codes and extension codes

Information about the aetiology and the manifestation of the condition of interest should be coded. In some instances, the ICD category refers to both (i.e. precoordinated), while in other instances more than one stem code (and/or extension code) needs to be used in order to express the relevant detail. This requires postcoordination.

E.g. Acute bleeding duodenal ulcer

Stem Code: [DA63.Z](#) Duodenal ulcer, unspecified Has manifestation (use additional code, if desired): [ME24.90](#) Acute gastrointestinal bleeding, not elsewhere classified Cluster: [DA63.Z/ME24.90](#)

However, postcoordination must never be used to replicate the meaning of a condition that is a precoordinated concept. The precoordinated code should be used.

E.g. Acute RSV bronchiolitis

Code: [CA41.0](#) Acute bronchiolitis due to respiratory syncytial virus Explanation: Since RSV bronchiolitis is a precoordinated concept in ICD-11, it is incorrect/prohibited to replicate the meaning of the diagnostic statement using a stem code and extension code (i.e. do not code: [\[CA41.Z\]](#) Acute bronchiolitis, unspecified&[XN275](#) *Human respiratory syncytial virus*)

E.g. Fracture, shaft of ulna

Code: [NC32.2](#) Fracture of shaft of ulna Explanation: Since fracture of shaft of ulna is a precoordinated concept in ICD-11, it is incorrect/prohibited to replicate the meaning of the diagnostic statement using a stem code and extension code (i.e. do not code: [NC32.Z](#) Fracture of forearm, unspecified&[XA8U33](#) shaft of the ulna)

There may be less obvious cases across the ICD. In an electronic environment, programmatically embedded instructions will help to avoid this kind of mistake. For reporting purposes, any correlated codes are linked using a forward slash (/) between stem codes and an ampersand (&) to separate stem codes with extension codes.

### 2.10.2 Combining stem codes and extension codes, and how to order these in a complex code cluster

Stem codes from other parts of ICD and extension codes can be linked together to describe a clinical concept in detail. They have to be grouped together in data transmission and evaluation in order to not lose the information conveyed by the joint group of codes. Such a group of codes is called a cluster. Cluster coding requires use of a specific syntax to indicate which codes belong together when postcoordination is used. This syntax has to comply with the following rules:

1. If only one stem code is coded, no clustering mechanisms need to be observed.

E.g. Condition: Acute ST elevation myocardial infarction [BA41.0](#) *Acute ST elevation myocardial infarction*

2. When postcoordinating to form a cluster, stem codes are always coded before extension codes. (Note, however, the complex clustering scenario depicted in Example 5 below, where a combination of multiple stem codes and linked extension codes are combined in a single complex cluster).
3. If one stem code is postcoordinated with one or more extension codes, the combining syntax used is the ampersand (&).

#### Example 1: Acute ST elevation myocardial infarction, anterior wall, LAD

Condition (code) - Acute ST elevation myocardial infarction [BA41.0](#) *Acute ST elevation myocardial infarction* Specific anatomy - [XA7RE3](#) *Anterior wall of heart*

Specific anatomy - [XA7NQ7](#) *Left anterior descending coronary artery* **Cluster:** [BA41.0&XA7RE3&XA7NQ7](#)

#### Example 2: Acute pyelonephritis, left side, E. coli Condition (code) - [GB51](#) *Acute pyelonephritis*

Laterality - [XK8G](#) *Left* Infectious agent - [XN6P4](#) *Escherichia coli* **Cluster:** [GB51&XK8G&XN6P4](#)

4. If two stem codes are postcoordinated to provide additional detail, it is important to follow the order (within a cluster) according to the use case (e.g. mortality or morbidity). The first stem code will be separated from the second stem code by a slash (/).

If only one code can be retained during data analysis for mortality (underlying cause of death) and public health prevention, priority of order should be given to the code that best describes the aetiology of a condition. If only one code can be retained for morbidity data analysis, priority should be given to the main condition (reason for admission after study established at the end of the episode of health care).

#### Example 3: Mortality (underlying cause of death) code ordering within a cluster

Patient died because of their diabetic coma. The patient had Type 2 diabetes mellitus. Condition (terminal cause of death): [5A23](#) *Diabetic coma* Condition (underlying cause of death): [5A11](#) *Type 2 diabetes mellitus* **Mortality cluster order:** [5A11/5A23](#)

#### Example 4: Morbidity (main condition) code ordering within a cluster (if only one code can be retained during data analysis)

Patient admitted to hospital in a diabetic coma. The patient had Type 2 diabetes mellitus. Main condition: [5A23](#) *Diabetic coma* Other condition: [5A11](#) *Type 2 diabetes mellitus* **Morbidity cluster order:** [5A23/5A11](#)

5. If a stem code is postcoordinated with extension codes and another stem code with some more extension codes is also coded within a cluster, the specific syntax should be designed to make a clear distinction between which extension codes in the cluster belong to which stem codes. The following syntax must be followed: The first stem code is reported, followed by an '&' followed by one or more extension codes, each of them separated by '&'. Then a slash '/' separates this first section of the cluster from the next stem code which is followed by '&' and the extension codes for this specific stem code, each again separated by '&'.

#### Example 5: stem code & extension code / stem code & extension code & extension code

Left inguinal hernia with acute obstruction Condition (code) - [DD51](#) *Inguinal hernia*  
Laterality - [XK8G](#) *Left*  
Has manifestation (use additional code, if desired) - [ME24.2](#) *Digestive system obstruction*  
Temporal pattern and onset - [XT5R](#) *Acute* **Cluster:** [DD51](#)&[XK8G](#)/[ME24.2](#)&[XT5R](#)

Postcoordination is only to be used to combine codes to describe and fully characterise a documented clinical concept. If the documentation describes two distinct clinical concepts that are represented by separate stem codes, they should not be reported together in a postcoordinated cluster.

#### Example 6: Pedestrian fall injury

Concussion and open fracture shaft of left ulna due to fall on uneven sidewalk:

Condition (code) 1 - [NA07.0Z](#) *Concussion, unspecified*  
Associated with (use additional code, if desired) - [PA60](#) *Unintentional fall on the same level or from less than 1 metre*  
Object or substance producing injury - [XE1DA](#) *Uneven surface, not elsewhere classified*  
Place of occurrence - [XE53A](#) *Sidewalk* **Cluster** - [NA07.0](#)/[PA60](#)&[XE1DA](#)&[XE53A](#)

Condition (code) 2 - [NC32.2](#) *Fracture of shaft of ulna*  
Laterality - [XK8G](#) *Left*  
Fracture open or closed - [XJ7YM](#) *Open fracture*  
Associated with: [PA60](#) *Unintentional fall on the same level or from less than 1 metre*  
Objects of living things involved in causing - [XE1DA](#) *Uneven surface, not elsewhere classified*  
Place of occurrence - [XE53A](#) *Sidewalk* **Cluster:** [NC32.2](#) & [XK8G](#)& [XJ7YM](#) /[PA60](#) & [XE1DA](#) & [XE53A](#)

Programmatically embedded instructions in the Foundation component of ICD-11 facilitate use of frequently used code combinations. Code combinations are not limited to the ones facilitated by these instructions. Additional instructions are added, based on user demands.

### 2.10.3 Diagnosis Timing - 'Present on admission' vs. 'Developed after admission'

Among the new Type 2 Extension codes -Diagnosis Code Descriptors, diagnosis timing is the particularly important set of extension codes that allow for distinction of diagnoses present on admission from diagnoses arising after admission, i.e. during the period of hospitalisation.

The latter distinction is particularly important, because it allows for the targeted identification of a number of in-hospital diagnoses that may represent adverse events associated with health care. The majority of coded concepts in a hospital record are conditions present on admission. Recognising this, it will be of significant interest to flag a diagnosis that developed after admission.

#### Example 1:

A patient with long-standing type 1 diabetes, admitted to hospital because of a myocardial infarction.

Main condition: Myocardial infarction

Other condition: Diabetes mellitus, type 1

In this instance, both conditions are present at admission, but one of them (myocardial infarction) does not need to be coded as being 'present on admission' because it is the main condition, designated in this example as being 'the condition that is determined to be the reason for admission, established at the end of the episode of health care'. The appropriate coding of this scenario therefore includes two clusters, each of which involves a stem code linked to an accompanying extension code i.e.:

- ‘Stem code for acute myocardial infarction’&‘Discharge Diagnosis Type Extension code for main condition’; [BA41.Z&XY0Y](#)
- ‘Stem code for diabetes mellitus type 1’&‘Diagnosis timing Extension code for present on admission’; [5A10&XY6M](#)

Note that for both coded entities in the above example, an ampersand (&) is used. In the first cluster, the stem code for myocardial infarction is linked to a diagnosis type extension code for main condition diagnosis type. In the second cluster, the stem code for diabetes mellitus type 1 is linked to a diagnosis timing extension code for present on admission.

#### Example 2:

A patient with long-standing type 1 diabetes, admitted to hospital because of chest pain. After assessment diagnosed with myocardial infarction. The patient develops deep vein thrombosis in right lower limb as an in-hospital complication of care.

Main condition: Myocardial infarction

Other conditions: Diabetes mellitus, type 1; Deep vein thrombosis (arising after hospital stay began)

In this example, a diagnosis timing extension code for ‘developed after admission’ is linked by cluster coding to a stem code for ‘deep vein thrombosis’. The first two diagnostic concepts, meanwhile, are coded exactly as per the preceding example. i.e.

- ‘Stem code for acute myocardial infarction’&‘Discharge Diagnosis Type Extension code for main condition’; [BA41&XY0Y](#)
- ‘Stem code for diabetes mellitus type 1’&‘Diagnosis Timing Extension code for present on admission’; [5A10&XY6M](#)
- ‘Stem code for lower limb deep vein thrombosis’&‘Right’&‘Diagnosis Timing Extension code for developed after admission’; [BD71.4&XK9K&XY69](#)

Again, each of the three cluster entities uses an ampersand ‘&’ because the second code (and third code) in the cluster is an extension code.

## 2.11 Functioning section

The Functioning section of ICD-11 allows coding and assessment of functioning in line with ICF but at an operational level. For detailed recording and assessment, the full ICF should be used. This section’s concepts are aligned with ICF and allow an easy transition to ICF. The design of the functioning section in ICD-11 addresses documentation and assessment of the level of functioning of persons, for

- general medical practice, as work incapacity assessment
- social benefits as for disability, or accident pension
- payment or reimbursement purposes
- needs assessment as in rehabilitation, occupational assistance, or long term care
- outcome evaluation of treatment

The functioning section in ICD-11 provides clinician-friendly tools for standardized assessment and documentation of functioning. The functioning section of ICD-11 allows for adding future additional assessment instruments.

## 2.11.1 Functioning assessment

### 2.11.1.1 WHO DAS 2.0: features and use cases

The WHO Disability Assessment Schedule (WHO-DAS 2.0) is the internationally, culturally and socioeconomically validated generic functioning assessment instrument for an adult population. WHO DAS 2.0 is focused on ICF Activity and Participation domains and allows to compute an overall and domain specific functioning score covering the following domains:

- Cognition – understanding & communicating
- Mobility– moving & getting around
- Self-care– hygiene, dressing, eating & staying alone
- Getting along– interacting with other people
- Life activities– domestic responsibilities, leisure, work & school
- Participation – joining in community activities, participating in society

WHO DAS scoring takes into account multiple levels of difficulty for each WHODAS 2.0 item (i.e. IRT based scoring). This type of scoring for WHODAS 2.0 allows for more fine-grained analyses that make use of the full information of the response categories for comparative analysis across populations or subpopulations. It takes the coding for each item response as “none”, “mild”, “moderate”, “severe” and “extreme” separately, and then uses a computation to determine the summary score by differentially weighting the items and the levels of severity.

The scoring has three steps:

- Step 1 – Summing of recoded item scores within each domain.
- Step 2 – Summing of all six domain scores.
- Step 3 – Converting the summary score into a metric ranging from 0 to 100 (where 0 = no disability; 100 = full disability).

The WHO DAS 2.0 scoring syntax is listed online via the link shared below.

Key features of WHO-DAS 2.0 include:

- ICF derived clinical scale with well-established psychometric properties of validity, reliability and sensitivity to change over time.
- Cardinal measure which is applicable across all health conditions and allows to generate an overall and domain specific functioning scores.
- Established population norms.

The combination of this features sets WHO DAS 2.0 apart from other clinical instruments.

WHO DAS 2.0 can be used for assessment of functioning in multiple use cases:

- Clinicians can quantify the effectiveness of their intervention within their clinical population and with reference to the general population.
- Disability evaluators can determine disability status in fair, transparent, impartial and comparable way.

- Reimbursement experts can measure quality (functioning outcome) of Case-mix/DRG groups.

WHO DAS 2.0 has been developed for use in adult population and currently does not assess body impairments or environmental factors. Users who wish to assess impairments in body functions and can make use of the WHO Model Disability Survey (MDS)[1] items which are also included in the function assessment part of the V Chapter.

WHO DAS 2.0 versions in three different formats (i.e. clinician administered, self-administered and proxy-administered) can be found via the link below.

WHO DAS 2.0 manual provides practical guidance for administering and scoring WHO DAS 2.0. including information on the simple and complex (Item-Response-Theory, IRT) scoring algorithm and population norms for the WHO DAS 12 and 36 item version. The WHO DAS 2.0 manual can be downloaded from the WHO website link - WHO Disability Assessment Schedule (WHODAS 2.0) - <https://www.who.int/standards/classifications/international-classification-of-functioning-disability-and-health/who-disability-assessment-schedule> together with other languages version of the WHO DAS 2.0.

[1] The MDS is a ICF based general population survey developed by WHO and the World Bank that provides detailed and nuanced information on the lives of people with disability. It allows direct comparison between groups with differing levels and profiles of disability.

#### **2.11.1.2 WHO DAS 2.0: representation and coding structure**

To enable easy information retrieval each WHO DAS 2.0 item has an assigned alphanumeric code to represent the captured concepts of the respective item. The code starts with the letters “VD” followed by a randomly assign number. Additional item specific information and values (i.e. item question, five-point response scale) are included in the ICD-11 APIs to allow for easy integration of the instrument and the automated scoring computation in any software application (e.g. integration of WHO DAS 2.0 as health outcome measure in EMR software). The six WHO DAS 2.0 domains under which the 36 items of the instrument are grouped are represented as block heading. Like other ICD-11 block headings they are assigned an URI but not a code. Table 1 below shows an example of how a WHO DAS 2.0 item are represented.



WHO DAS 2.0 item	ICD-11 Code	URI
Attention functions	<a href="#">VD00</a>	<a href="http://id.who.int/icd/entity/532448599">http://id.who.int/icd/entity/532448599</a>
Item description question	Item response scale value set	Mapped ICF category
Because of your health condition, in the past 30 days, how much difficulty did you have in concentrating on doing something for ten minutes?	1=no difficulty, 2=mild difficulty, 3=moderate difficulty, 4=severe difficulty, 5=complete difficulty	d160 Focusing attention

## 2.11.2 Generic functioning entity

### 2.11.2.1 Functioning entities: features and use cases

The main tool for documenting functioning is a list of generic functioning domains derived from the ICF Annex 9 and the ICF generic core set.

The generic list allows clinicians to generate a coded functioning profile of an individual which can be used for multiple purposes like - goal setting - monitoring change - communicating across the continuum of care.

Because the list is directly linked to the ICF, it may - Facilitate joint use of ICD & ICF (code once – use multiple times) - Serve as an entry point the use of the full ICF.

### 2.11.2.2 Functioning entity: representation and coding structure

In accordance with the WHO FIC content model a functioning entity has two components i.e. category and a qualifier. Both have an assigned alphanumeric code and an URI to represent the captured concepts. The code starts with the letters “VV” followed by a randomly assign number. The functioning category and the qualifier are linked through postcoordination.

## 2.12 Electronic recording and reporting

Electronic documentation will follow the principle of lossless collection of information at the source. Best practice includes reporting of:

1. A text field that captures the clinical term or cause of death with the exact wording reported by the health provider, and
2. A data field that retains the identifier (URI) of the chosen entity of ICD-11 (index, code title or other element) that represents the most exact match for that text.
3. A data field for the relevant ICD-11 code.

In this way, the quality of the coding can be verified at any point in time. Also, specific conditions can be identified and analysed, independently of them being linked to an individual ICD code or lumped together in a code with other conditions.

Coding shall be done using tools based on the ICD-11 API, like the ICD-11 coding tool. Software must not include lists or other prompts to guide the recording or coding, as these

necessarily limit the range of diagnoses and therefore have negative impact on the accuracy and usefulness of the record and report.

## 2.13 Foundation Component and Tabular lists

The Foundation Component is a multi-dimensional collection of all ICD entities. Entities can be diseases, disorders, injuries, external causes, signs and symptoms. Some entities may be very broad, for example 'Injuries to the elbow or forearm', while others are more detailed, for example 'Fracture of upper end of ulna, extending into joint'. The Foundation Component also has the necessary information to use the entities to build a tabular list. The Foundation Component includes information on where and how a certain entity is represented in a tabular list, whether it becomes a grouping, a category with a stem code, or whether it is mentioned as an inclusion term in a particular category.

Several different tabular lists can be built from the Foundation Component. Drawing on the same Foundation Component, a set of tabular lists that builds on the same hierarchical tree structure can be created – producing congruent tabular lists. The Foundation Component includes instructions on how to combine certain codes in a tabular list to achieve more detail in coding. These rules help coders and computer systems to visualise the permitted code combinations when they are using a tabular list.

### **Core tabular lists for international use:**

- Mortality and Morbidity Statistics (MMS)
- Primary care low resources settings (PCL)
- Verbal Autopsy (VA)
- Startup Mortality List (SMoL)

The full name of such a tabular list will always include 'ICD-11', e.g. ICD-11 MMS.

In a Tabular list, entities of the Foundation Component become categories. The categories are mutually exclusive and jointly exhaustive and linked to a mono hierarchical tree (they have only one parent). The information related to an entity that has become a category and has multiple parents is still available from the Foundation. This information can be used to visualise that category in more than one place in the Tabular list, e.g. showing them in black in its place for reference tabulation and in grey in any other place for browsing or alternative tabulations. ICD-11 has multiple congruent tabular lists with varying levels of detail.

The Foundation Component is also the data source for production and maintenance of Tabular lists, index and the Reference Guide. It also includes additional content (see 'content model') that goes beyond the traditional paper-based use of a classification. Depending on the setting within a country, it may be decided to use the full Foundation Component or to focus on the parts that are essential to production and maintenance of the Index and the Tabular list.

The Foundation Component serves to align the content of the different tabular lists and to define their categories. As such it allows standardised use of the ICD-11, independent of the setting in which it is used. The Foundation Component includes, for example, links to other classifications or terminologies that can be expanded in the future. Please note that the

mention of a term or entity in the Foundation exclusively serves ontological purposes. Mention of a term or entity in the Foundation does not mean approval or endorsement of a particular condition.

## 2.14 Main uses of the ICD: Mortality

This section concerns the rules and guidelines adopted by the World Health Assembly regarding the selection of a single cause or condition for routine tabulation from death certificates. Guidelines are also provided for the application of the rules and for coding of the condition selected for tabulation. Implementation of the ICD for mortality requires setting up an infrastructure for reporting and storing information, designing information flows, quality assurance and feedback, and training for classification users working with the input or output of data.

Following the introductory information in this Section and [2.15](#), Section [2.16](#) explains the basic concepts used in mortality coding. Sections [2.17](#) - [2.20](#), supplemented by Annexes in Section [3.14](#), guides how to code and identify the underlying cause of death, and Section [2.25](#) explains descriptions used in statistical tabulation and international reporting for mortality.

## 2.15 Mortality statistics

Mortality statistics are widely used for medical research, monitoring of public health, evaluating health interventions, allocation of health resources and planning and for, and follow-up of health care. Analysis of mortality data typically involves comparisons of data sets, for example those representing different geographical regions or different points in time. Unless the data have been produced by the same methods and according to the same standards, such comparisons will yield misleading results.

To standardise production of mortality data, WHO issues international instructions on data collection, coding and classification, and statistical presentation of causes of death. It is of utmost importance that production of mortality data follows the procedures detailed next, since any deviation from the international instructions will impair international comparability. The description of a single underlying cause of death, and selected approaches to capture further information on causes of death also reported on a certificate, enables the identification of trends in health for a given population. The following sections contain information on coding causes of death for mortality statistics. They explain the basic concepts, how to code conditions reported on death certificates, and how to select and tabulate the underlying cause of death.

The aim of these instructions is to optimise the mortality statistics from a public health point of view. Some of the instructions may appear wrong or questionable from a purely medical perspective. They should still not be set aside, since they may be motivated by well-founded epidemiological and public health principles. If an apparent error is found, it should be reported to WHO through the online proposal mechanism. WHO will either explain the rationale or take steps to correct the error at the international level. Individual countries should not correct what is assumed to be an error, since changes at the national level will lead to data that are less comparable to data from other countries, and thus less useful for analysis.

### 2.15.1 What is tabulated: Underlying cause of death

Effective public health interventions prevent harm or death by breaking the chain of events that lead to harm. For this purpose, the underlying cause of death has been defined as ‘(a) the disease or injury which initiated the train of morbid events leading directly to death, or (b) the circumstances of the accident or violence which produced the fatal injury’, and is selected for routine single-cause tabulation of mortality statistics. See Sections [2.17.2 Selecting the underlying cause of death](#) and [2.17 Coding instructions for mortality](#) for specific coding instructions to identify the underlying cause of death.

### 2.15.2 Data source: The international form of Medical Certificate of Cause of Death (MCCD)

The international mortality coding instructions presuppose that data have been collected with a death certificate conforming to the international form of Medical Certificate of Cause of Death as recommended by the WHO. Frame A, the medical data part of the international form is split into two parts: Part 1 is for diseases related to the chain of events directly leading to death, and Part 2 is for other significant conditions contributing to death. Other information in the form is also used in identifying the underlying cause of death for tabulation.

In order to align the way this information is collected internationally, the form should be followed as closely as possible. Otherwise, the causes of death cannot be coded and selected according to the international standard and the data will not be internationally comparable. For example, some coding instructions apply to conditions reported as caused by certain other conditions, and in such cases, it is important to have a clear distinction between causes reported in Part 1 and in Part 2 of the death certificate. Further, information reported elsewhere on the certificate, such as manner of death or whether pregnancy contributed to the death, is essential when assigning multiple cause codes to the conditions stated on the certificate and selecting an underlying cause for tabulation.

It is the responsibility of the medical practitioner or other qualified certifier signing the death certificate to indicate which morbid conditions led directly to death and to state any pre-existing conditions giving rise to this cause. The certifier should use his or her clinical judgement in completing the medical certificate of cause of death. Automated systems must not include lists or other prompts to guide the certifier, as these necessarily limit the range of diagnoses and therefore have an adverse effect on the accuracy and usefulness of the report.

<b>Administrative Data</b> (can be further specified by country)																	
Sex	<input type="checkbox"/> Female				<input type="checkbox"/> Male				<input type="checkbox"/> Unknown								
Date of birth	D	D	M	M	Y	Y	Y	Y	Date of death	D	D	M	M	Y	Y	Y	Y
<b>Frame A: Medical data: Part 1 and 2</b>																	
<b>1</b> Report disease or condition directly leading to death on line a  Report chain of events in due to order (if applicable)  State the underlying cause on the lowest used line		a	Cause of death	Time interval from onset to death													
		b	Due to:														
		c	Due to:														
		d	Due to:														
<b>2</b> Other significant conditions contributing to death (time intervals can be included in brackets after the condition)																	
<b>Frame B: Other medical data</b>																	
Was <b>surgery</b> performed within the last 4 weeks? <input type="checkbox"/> Yes <input type="checkbox"/> No <input type="checkbox"/> Unknown																	
If yes please specify date of surgery																	
If yes please specify reason for surgery (disease or condition)																	
Was an autopsy requested? <input type="checkbox"/> Yes <input type="checkbox"/> No <input type="checkbox"/> Unknown																	
If yes were the findings used in the certification? <input type="checkbox"/> Yes <input type="checkbox"/> No <input type="checkbox"/> Unknown																	
<b>Manner of death:</b>																	
<input type="checkbox"/> Disease			<input type="checkbox"/> Assault			<input type="checkbox"/> Could not be determined											
<input type="checkbox"/> Accident			<input type="checkbox"/> Legal intervention			<input type="checkbox"/> Pending investigation											
<input type="checkbox"/> Intentional self harm			<input type="checkbox"/> War			<input type="checkbox"/> Unknown											
If external cause or poisoning:								Date of injury		D	D	M	M	Y	Y	Y	Y
Please describe how external cause occurred (If poisoning please specify poisoning agent)																	
<b>Place of occurrence of the external cause:</b>																	
<input type="checkbox"/> At home		<input type="checkbox"/> Residential institution		<input type="checkbox"/> School, other institution, public administrative area				<input type="checkbox"/> Sports and athletics area									
<input type="checkbox"/> Street and highway		<input type="checkbox"/> Trade and service area		<input type="checkbox"/> Industrial and construction area				<input type="checkbox"/> Farm									
<input type="checkbox"/> Other place (please specify):								<input type="checkbox"/> Unknown									
<b>Fetal or infant Death</b>																	
Multiple pregnancy								<input type="checkbox"/> Yes		<input type="checkbox"/> No		<input type="checkbox"/> Unknown					
Stillborn?								<input type="checkbox"/> Yes		<input type="checkbox"/> No		<input type="checkbox"/> Unknown					
If death within 24h specify number of hours survived								Birth weight (in grams)									
Number of completed weeks of pregnancy								Age of mother (years)									
If death was perinatal, please state conditions of mother that affected the fetus and newborn																	
<b>For women, was the deceased pregnant?</b> <input type="checkbox"/> Yes <input type="checkbox"/> No <input type="checkbox"/> Unknown																	
<input type="checkbox"/> At time of death								<input type="checkbox"/> Within 42 days before the death									
<input type="checkbox"/> Between 43 days up to 1 year before death								<input type="checkbox"/> Unknown									
Did the pregnancy contribute to the death?								<input type="checkbox"/> Yes		<input type="checkbox"/> No		<input type="checkbox"/> Unknown					

The 2016 International form of the Medical Certificate of Cause of Death

See [3.14 Annex C: Annexes for Mortality Coding](#) for further details and guidance.

## 2.15.3 Routine use and special cases

### 2.15.3.1 Routine cause of death reporting systems

In routine cause of death reporting systems, every individual death is certified by a qualified medical doctor who carries out an accurate postmortem examination, collects history from relatives, and has access to all pre-existing medical information about the defunct. The medical certification of the cause of death is usually the responsibility of the attending physician and should be in line with international recommendations. Administrative procedures should ensure confidentiality of data from death certificates or other medical records.

In the case of deaths certified by coroners or other legal authorities, the medical evidence supplied to the certifier should be stated on the certificate in addition to any legal findings.

Routine cause of death reporting is usually embedded in the certification of death process. Death certificates are a legal requirement for burial and for inheritance.

### 2.15.3.2 Verbal autopsy

Verbal autopsy (VA) is a method used to ascertain the cause of a death based on an interview with next of kin or other caregivers where no medical certification is available. This is done using a standardised instrument that elicits information on signs, symptoms, medical history, and circumstances preceding death. The cause of death, or the sequence of causes that led to death, are assigned based on the data collected by the instrument and other available information. Rules and guidelines, algorithms or computer programs, may assist in evaluating the information to determine the cause of death.

The main objective of the VA is to describe the causes of death at the community or population level in areas, where civil registration and death certification systems are weak and where most people die at home without having had contact with the health system. A standard VA instrument comprises a VA questionnaire, cause of death or mortality classification system, and diagnostic criteria (either expert or data derived algorithms) for deriving causes of death.

The VA process consists of interviews, data recording, and identification of the cause of death from the reports. At any step, factors can influence the cause-specific mortality fractions estimated throughout the process. Besides research, VA is a viable method for causes of death identification in settings where no physician can evaluate the deceased. More information can be found on the [WHO Verbal autopsy webpage](#).

See [3.14.14 Target list of causes of death for verbal autopsy](#) with corresponding ICD-11 codes.

## 2.16 Basic concepts

Mortality coders must be familiar with the basic concepts introduced in this section.

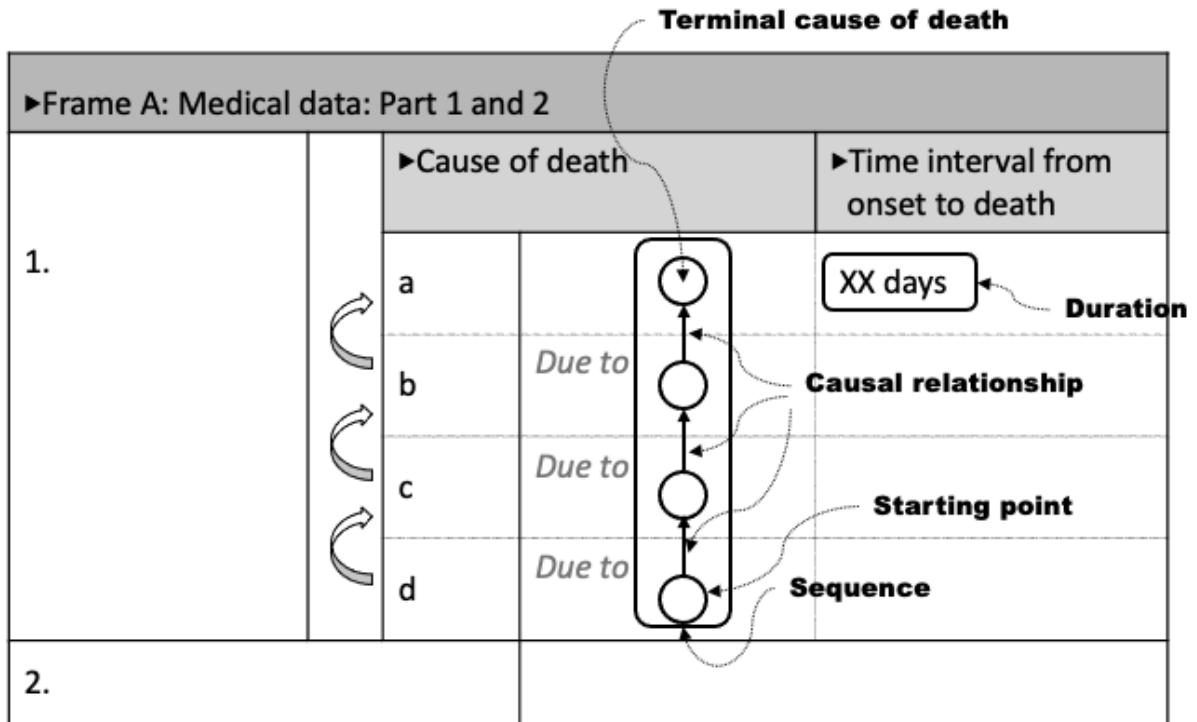

### Basic Concepts

Basic concepts for mortality coding in the international form of the Medical Certificate of Cause of Death

#### 2.16.1 Terminal cause of death

The disease or condition entered first on the first used line of Part 1 of the death certificate is the cause directly leading to death. This is known as the terminal or immediate cause of death.

#### Example 1

- 1 (a) Myocardial infarction  
*due to*
- (b) Coronary atherosclerosis  
*due to*
- (c)  
*due to*
- (d)

2

The myocardial infarction is the terminal cause of death, since it is entered first on the first used line of the certificate.

## Example 2

- 1 (a) Myocardial infarction and pulmonary oedema  
*due to*
  - (b) Coronary atherosclerosis  
*due to*
  - (c)  
*due to*
  - (d)
- 2

The myocardial infarction is the terminal cause of death, since it is entered first on the first used line of the certificate.

### 2.16.2 Causal relationship and sequence

A causal relationship exists if a condition mentioned on the death certificate can be caused by another condition also mentioned on the certificate. The term 'sequence' refers to a chain or series of medical events in which each step is a complication of, or is caused by, the previous step. A causal relationship can exist between any two conditions, including conditions assigned to the same ICD-11 code, regardless of where each condition was reported. In a correctly completed death certificate, a sequence is a set of conditions reported line by line with a causal relationship between each element. Four lines are provided in Part 1 of the certificate for recording the sequence of events leading to the death. A certifier may only use as many lines as are required to describe the sequence.

A causal relationship is considered acceptable for mortality coding if it is founded not only on a medical assessment but also on epidemiological and public health considerations. Therefore, a medically acceptable relationship might be listed as unacceptable in the coding instructions because a later step in the sequence is more important from a public health point of view.

In addition, a reported sequence that appears improbable should be accepted if one or more intervening steps would explain the causal relationship, even if these have not been reported. However, such assumed intervening causes are not to be coded, as they are assumptions and not reported conditions.

To decide whether a stated causal relationship is acceptable, always apply the instructions in Section [2.19.1 Special instructions on accepted and rejected sequences \(Steps SP3 and SP4\)](#). Stated relationships that are not listed in Section [2.19.1](#) should be accepted as far as possible, because the certifier's opinion about the causes leading to death should not be disregarded.



### Example 1

- 1 (a) Myocardial infarction  
*due to*
  - (b) Coronary thrombosis  
*due to*
  - (c) Coronary atherosclerosis  
*due to*
  - (d)
- 2

The terminal cause of death is myocardial infarction. It is caused by the coronary thrombosis, which, in turn, is caused by coronary atherosclerosis. Consequently, the sequence is: myocardial infarction due to coronary thrombosis due to coronary atherosclerosis.

### Example 2

- 1 (a) Extensive haemorrhage  
*due to*
  - (b) Traumatic amputation of right leg  
*due to*
  - (c) Run over by a bus  
*due to*
  - (d)
- 2

The terminal cause of death is haemorrhage. It is a complication of the traumatic amputation of the right leg, which, in turn, is caused by the bus accident. Consequently, the sequence is: extensive haemorrhage due to traumatic amputation of the right leg due to being run over by a bus.

### 2.16.3 Starting point

The starting point is the condition or event that started the sequence of acceptable causal relationships ending with the terminal cause of death. In a correctly completed death certificate, the condition reported first on the lowest used line in Part 1 is the starting point of the sequence. The instructions on how to identify the starting point is provided in [Section 2.17.3 Find the starting point \(Steps SP1 to SP8\)](#).

If the death certificate is not correctly filled out, the starting point may be reported elsewhere, and instructions are given to identify the starting point also for such cases in a standardised manner. Therefore, it is important to apply the instructions in [Section 2.17.3](#) in a sequential manner.

The condition provisionally considered as the starting point when applying the instructions step by step is referred to as the 'tentative starting point (TSP)' and may change several times as the instructions are applied to the death certificate.

### Example 1

- 1 (a) Myocardial infarction and pulmonary oedema  
*due to*
  - (b) Coronary atherosclerosis  
*due to*
  - (c)  
*due to*
  - (d)
- 2

Coronary atherosclerosis is the starting point, since it led to the myocardial infarction.

### Example 2

- 1 (a) Pneumonia  
*due to*
  - (b) Hip fracture  
*due to*
  - (c) Tripped on carpet  
*due to*
  - (d)
- 2

Tripped on carpet is the starting point, since it started the sequence of events leading to death.

#### 2.16.4 Duration

On death certificates, each reported condition should also include information about duration. The duration refers to the interval from the onset of the disease or condition to the time of death. Note that it is not always the same as the time of diagnosis of the condition, which may be at the same time as, or after, the onset of symptoms.

#### 2.16.5 First-mentioned sequence

A death certificate may contain several sequences of acceptable causal relationships ending with the terminal cause of death. The coding instructions are given to identify the starting point of the first-mentioned sequence in Part 1 (See also Step SP4).

The figures below illustrate examples of certificates where each condition reported is shown by a circle. The starting point of the first-mentioned sequence is in grey, and the causal relationship of the first-mentioned sequence is indicated by an arrow.

To identify the first-mentioned sequence, begin with the terminal cause of death (the condition entered first on the first used line of Part 1). Check if the conditions on the next line in Part 1 can result in the terminal cause of death. If several conditions are reported on the same line, check from left to right in turn until you find a condition that could cause the terminal cause.

If no condition on the next line can cause the terminal cause of death, there is no sequence ending with the terminal cause of death. The terminal cause of death is the tentative starting point. Specific instruction is given also when you find no sequence (see Step SP5).

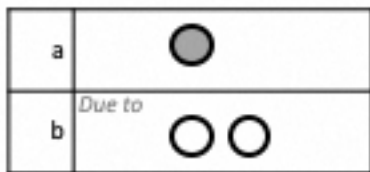

*NoSequence*

No Sequence ending with the terminal cause of death

If there is a condition that can cause the terminal cause of death, the first condition found to be able to cause the terminal cause of death is the tentative starting point. If there are no conditions reported on lower lines, the sequence between this tentative starting point and the terminal cause is the first-mentioned sequence.

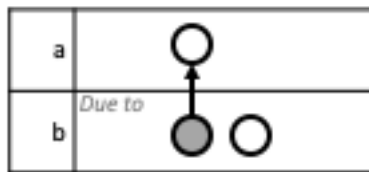

*First Mentioned Sequence A*

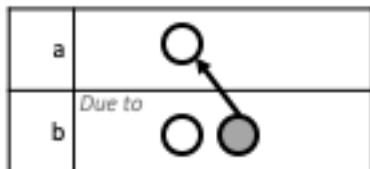

*First Mentioned Sequence B*

If there are conditions reported on lower lines in Part 1, repeat the procedure for the next lower line. Start with the tentative starting point identified in the previous step. Check the conditions on the next lower line in Part 1, from left to right, to determine if they can cause the tentative starting point. Continue until you have found a condition that can cause the tentative starting point. This is the new tentative starting point.

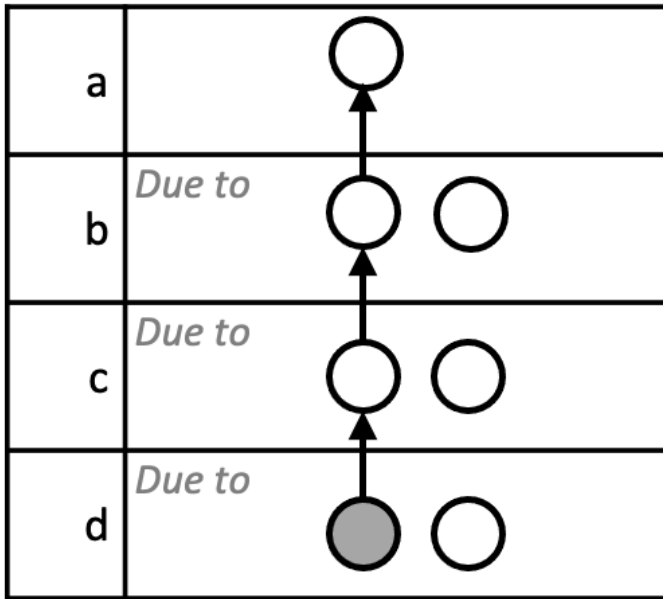

*First Mentioned Sequence C*

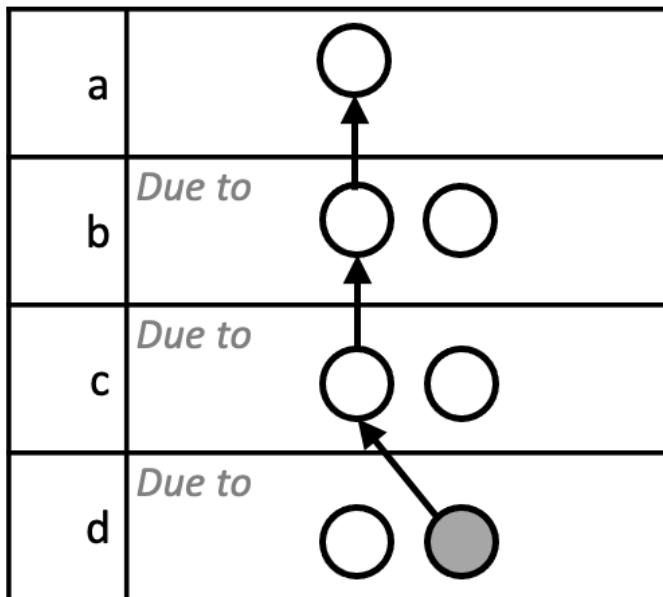

*First Mentioned Sequence D*

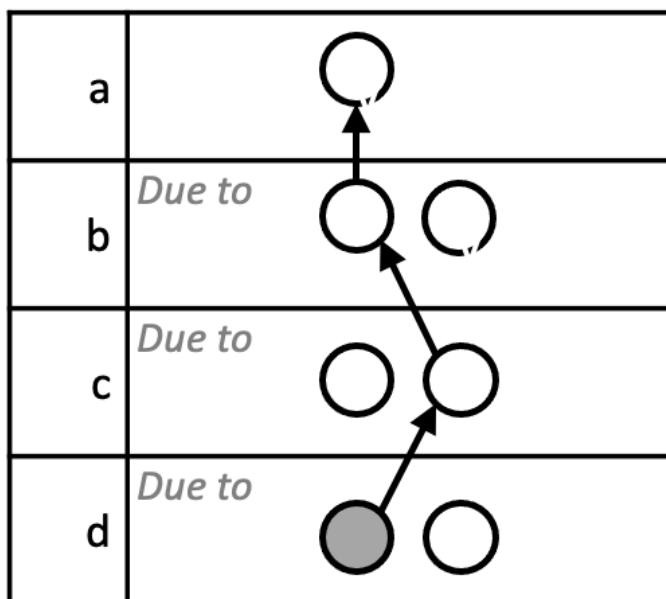

*First Mentioned Sequence E*

If there are still conditions reported on lower lines in Part 1, repeat the procedure for as long as a new tentative starting point can be identified. When no condition can be found that could cause the tentative starting point, the last identified tentative starting point is also the starting point of the first-mentioned sequence.

Example 1

- 1 (a) Pneumonia  
*due to*
- (b) Hip fracture and heart failure  
*due to*
- (c) Tripped on carpet, coronary atherosclerosis  
*due to*
- (d)
- 2

Pneumonia can be due to hip fracture, and therefore hip fracture is the tentative starting point. Hip fracture can be due to tripping, which is the new tentative starting point. Since there are no causes reported below line 1(c), tripping on carpet is the starting point of the first-mentioned sequence.

### Example 2

- 1 (a) Pneumonia  
*due to*
  - (b) Heart failure and hip fracture  
*due to*
  - (c) Coronary atherosclerosis and tripped on carpet  
*due to*
  - (d)
- 2

Pneumonia can be due to heart failure, and therefore heart failure is the tentative starting point. Heart failure can be due to coronary atherosclerosis, which is the new tentative starting point. Since there are no causes reported below line 1(c), coronary atherosclerosis is the starting point of the first-mentioned sequence.

### Example 3

- 1 (a) Pneumonia  
*due to*
  - (b) Hip fracture and heart failure  
*due to*
  - (c) Coronary atherosclerosis and tripped on carpet  
*due to*
  - (d)
- 2

Pneumonia can be due to hip fracture, and therefore hip fracture is the tentative starting point. However, hip fracture cannot be due to coronary atherosclerosis, but hip fracture can be due to tripping, which is the new tentative starting point. Since there are no causes reported below line 1(c), tripped on carpet is the starting point of the first-mentioned sequence.

### 2.16.6 Underlying cause of death (UCOD)

The underlying cause of death (UCOD), as defined in Section [2.15.1](#), is the condition selected for single-cause tabulation of mortality statistics.

A condition that is provisionally considered as the underlying cause of death when applying the instructions step by step is referred to as a 'tentative underlying cause of death (TUC)' and may change several times as the instructions are applied to the death certificate.

Example 1

- 1 (a) Myocardial infarction  
*due to*
- (b) Coronary atherosclerosis  
*due to*
- (c) Generalised atherosclerosis  
*due to*
- (d)
- 2

Generalised atherosclerosis started the sequence of events leading to death, so it is the starting point. There are special modification instructions relating to atherosclerosis and coronary heart disease in the ICD, and, in the next step, coronary atherosclerosis is selected as the tentative underlying cause of death. But there are further instructions on coronary atherosclerosis and myocardial infarction, and in the final step, myocardial infarction is selected as the tentative underlying cause, and is the underlying cause of death in this case.

2.16.7 Priority underlying condition

Some mortality coding instructions (e.g. Steps SP6, M1) refer to the ‘priority underlying condition’. It is a concept to set a priority order giving precedence to the underlying condition, when specific requirements in each instruction apply to several conditions in the death certificate.

To identify the priority underlying condition, start from the first condition reported on the lowest used line of Part 1. If there are several conditions reported, search from the lowest used line, and the next line above in turn, and from left to right for each line. If you cannot find the priority underlying condition in Part 1, then search Part 2, again from left to right.

1	a		⑦	⑧	
	b	<i>Due to</i>	⑤	⑥	
	c	<i>Due to</i>	③	④	
	d	<i>Due to</i>	①	②	
2			⑨	⑩	

*Priority Underlying Condition*

## 2.16.8 Modification

Special coding instructions on specific sequences and ICD categories may have the effect that a condition other than the starting point is selected as the underlying cause of death for use in the statistics. In such cases, the code for underlying cause often expresses a combination of the starting point with another reported condition, or a complication or consequence of the starting point that is of particular importance to public health. The procedure by which the ICD code for the starting point is replaced by another code is called modification. Instructions on how to apply these special instructions to identify the underlying cause of death is given in Section [2.18 Check for modifications of the starting point \(Steps M1 to M4\)](#).

### Example 1

- 1 (a) Heart disease  
*due to*
  - (b) Generalised atherosclerosis  
*due to*
  - (c)  
*due to*
  - (d)
- 2

Generalised atherosclerosis started the sequence of events leading to death, so it is the starting point. However, according to a special instruction on generalised atherosclerosis, generalised atherosclerosis leading to heart disease is assigned to atherosclerotic heart disease in mortality statistics. Because of this modification, atherosclerotic heart disease is the underlying cause of death.

## 2.17 Coding instructions for mortality

When coding causes of death, first assign ICD codes to all the conditions mentioned on the death certificate. Many coding instructions are based on specific ICD codes, and to determine whether or not any of the instructions apply, all conditions on the certificate must be coded. Other conditions reported on the certificate may affect the coding any condition. Assigning codes for all reported conditions and applying any effect one code has on another is called multiple cause coding.

### 2.17.1 Basic coding and multiple cause coding guidelines

To start coding, refer to basic coding guidelines given in sections in the beginning of Part 2 (for example Sections [2.1](#), [2.6](#), and [2.10.1](#)). When multiple causes are reported also refer to Section [2.20 Coding instructions for mortality: multiple cause coding and other specific instructions](#). Multiple cause coding permits in-depth analysis of causes of death, for example of serious but avoidable complications of certain underlying causes, and the impact of coexisting conditions on the outcome of a disease process. Therefore, in mortality coding, both underlying cause and multiple causes should be recorded. Complete multiple cause coding is essential for a correct application of the ICD instructions for selection and modification of the underlying cause of death.



To ensure consistent reporting of emerging conditions of international public health importance, WHO may sometimes publish special instructions for coding of named conditions, or selection of the underlying cause of death where named conditions are mentioned on the Medical Certificate Cause of Death (MCCD). This will usually involve codes in Chapter 25: Codes for special purposes - International provisional assignment of new diseases of uncertain aetiology and emergency use. Such special instructions should be applied in preference to any instructions in the Reference Guide that would otherwise apply.

Once ICD codes are assigned to each disease or condition on the certificate, apply the instructions to select the underlying cause of death.

### 2.17.2 Selecting the underlying cause of death

For most death certificates, selecting the underlying cause of death is a straightforward procedure. There are, however, many cases where the underlying cause is not immediately obvious. To ensure that both straightforward and complex cases are coded according to the ICD mortality rules, it is important to follow the coding instructions carefully, step by step. Otherwise, the resulting mortality statistics will not be internationally comparable, which seriously reduces the value of the data for public health purposes.

Selecting the underlying cause of death involves two separate steps. The first step is to identify the starting point (Steps SP1 through SP8 below). The next step is to modify the starting point, if any of the modification instructions apply, to reflect further information provided on the death certificate (Steps M1 through M4 below). See Sections [2.18](#) - [2.19](#) for specific instructions. In addition, Mortality Annex [3.14.4](#) includes a workflow diagram to illustrate the coding instructions for the selection of the underlying cause of death. This is intended as a supplement to help coders follow the coding instructions.

Note that the purpose of the selection procedure is to produce the most useful mortality statistics possible. Thus, the following instructions may reflect the importance of some conditions for public health rather than what is correct from a purely medical point of view. The following instructions always apply, whether they might be considered medically correct or not.

In the coding examples that follow, the 'due to' statement between the lines in Part 1 is not included. But it is important to bear in mind that anything reported on an upper line in Part 1 is meant to be due to what is reported on the line below.

First assign ICD codes to all conditions mentioned on the death certificate see Section 'Coding Instructions for mortality: multiple causes'

**Workflow diagram of the application of the coding instruction for the selection of underlying cause of death**

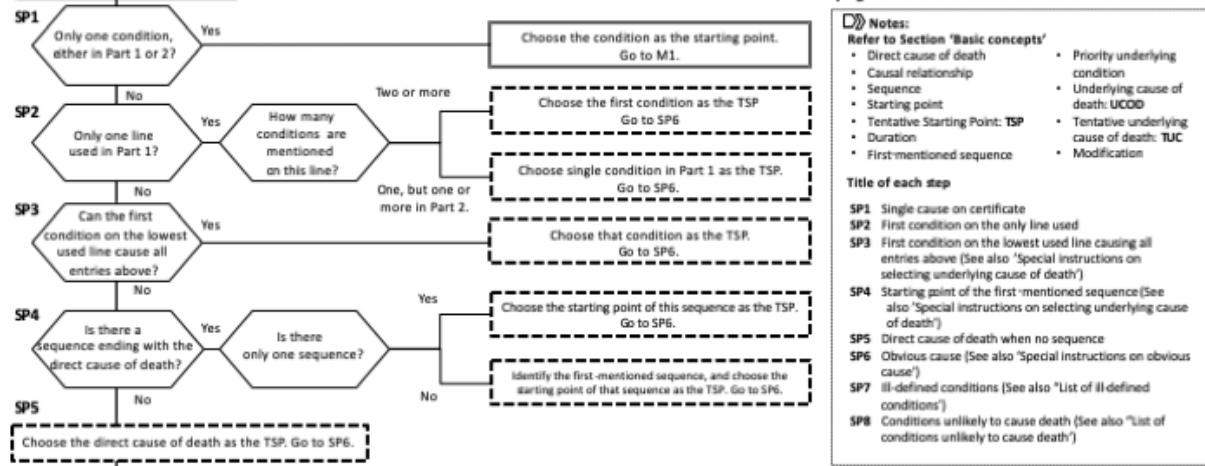

- Notes:**
- Refer to Section 'Basic concepts'
  - Direct cause of death
  - Causal relationship
  - Sequence
  - Starting point
  - Tentative Starting Point: TSP
  - Duration
  - First-mentioned sequence
  - Priority underlying condition
  - Underlying cause of death: UCOD
  - Tentative underlying cause of death: TUC
  - Modification
- Title of each step**
- SP1 Single cause on certificate
  - SP2 First condition on the only line used
  - SP3 First condition on the lowest used line causing all entries above (See also 'Special instructions on selecting underlying cause of death')
  - SP4 Starting point of the first-mentioned sequence (See also 'Special instructions on selecting underlying cause of death')
  - SP5 Direct cause of death when no sequence
  - SP6 Obvious cause (See also 'Special instructions on obvious cause')
  - SP7 Ill-defined conditions (See also 'List of ill-defined conditions')
  - SP8 Conditions unlikely to cause death (See also 'List of conditions unlikely to cause death')

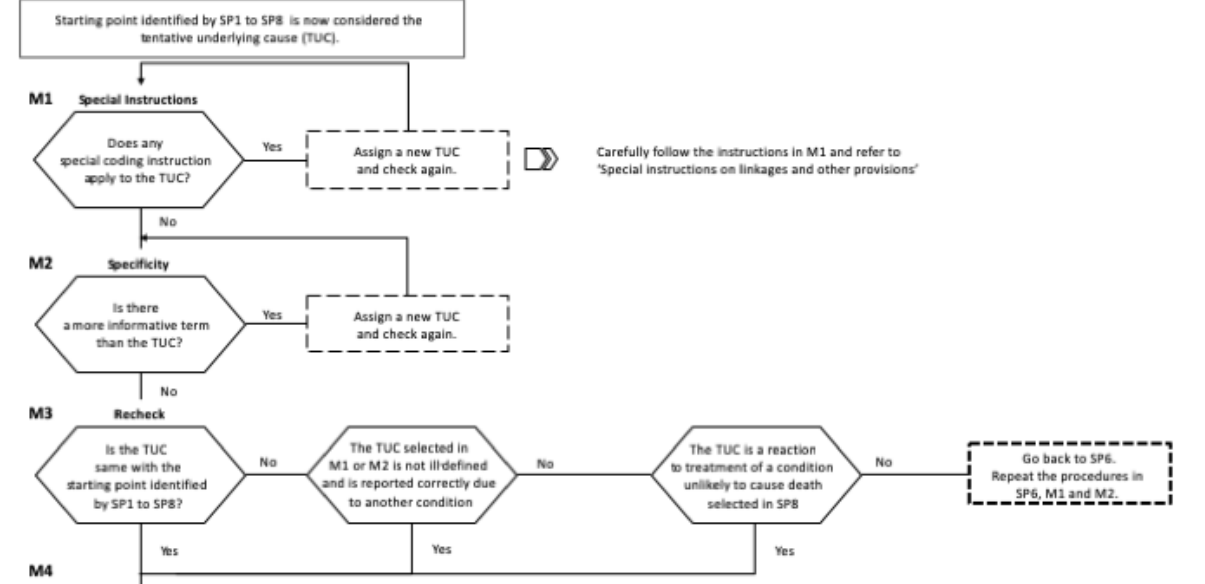
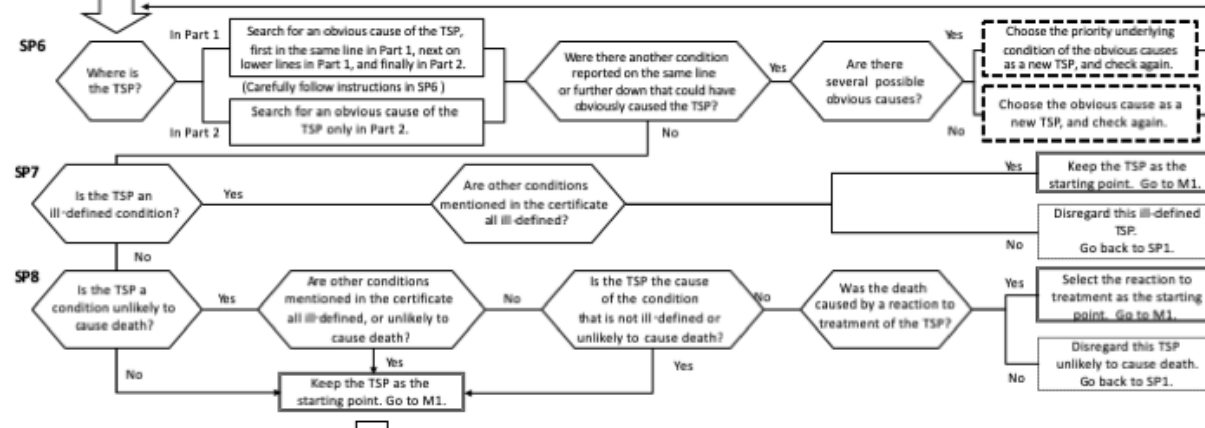

TUC is...	Special instructions	Refer to Section...
Surgery or medical procedure		'Surgery and other medical procedures'
Chapter 22 Injury or poisoning	Code the external cause as the UCOD and add the main injury	
Chapter 23 External cause	Add the main injury.	'Main injury in death from external causes'
Poisoning and more than toxic substance is reported	Identify the most important drug involved.	'Poisoning by drugs etc.'
Decedent is a woman and pregnancy, childbirth or puerperium is reported.	Determine whether to assign Chapter 18 as the UCOD	'Maternal mortality'

## Workflow

Workflow diagram of steps SP1 to SP8, and to Steps M1 to M4 for mortality coding.

### 2.17.3 Find the starting point (Steps SP1 to SP8)

To identify the starting point, follow the eight steps specified in this section. The steps are named SP1 to SP8 (Starting point rule 1 to Starting point rule 8). Each step contains one selection rule. At each step, there is a description of the selection rule itself and an instruction on what to do next.

### 2.17.4 Step SP1 – Single cause on certificate

If there is only one condition reported on the certificate, in either Part 1 or Part 2, this is the starting point. Next verify whether either step M1 or M4 apply, go to Section [2.18 Check for modifications of the starting point \(Steps M1 to M4\)](#).

If there are two or more conditions on the certificate, go to Step SP2.

### 2.17.5 Step SP2 – First condition on the only line used

If the certifier has used only one line in Part 1 and:

- has reported only one condition on this line, but has reported one or more conditions in Part 2, then the single condition in Part 1 is the tentative starting point. Next, go to Step SP6.
- has reported two or more conditions on this line, then the first condition is the tentative starting point. This applies whether or not one or more conditions are reported in Part 2. Next, go to Step SP6.

If the certifier has used more than one line in Part 1, go to Step SP3.

If the certifier has used only Part 2, but has reported two or more conditions there, then the first condition is the tentative starting point.

#### Example 1

- 1 (a) Myocardial infarction and diabetes mellitus  
(b)  
(c)  
(d)
- 2

Myocardial infarction is mentioned first on the certificate and is the tentative starting point. Next, go to Step SP6, to check whether further selection and modification rules apply.

### Example 2

- 1 (a) Myocardial infarction
- (b)
- (c)
- (d)
- 2 Diabetes mellitus

Myocardial infarction is mentioned first on the certificate and is the tentative starting point. Next, go to Step SP6, to check whether further selection and modification rules apply.

#### 2.17.6 Step SP3 – First condition on the lowest used line causing all entries above

If there are conditions reported on more than one line in Part 1, check if each of the conditions reported on the line(s) above the lowest used line in Part 1 can be caused by the first condition on the lowest used line.

- If yes, then this condition is the tentative starting point. Next, go to Step SP6.
- If not, go to Step SP4.

To assess causal relationship, refer to Section [2.16.2 Causal relationship and sequence](#), and to Section [2.19.1 Special instructions on accepted and rejected sequences \(Steps SP3 and SP4\)](#).

### Example 1

- 1 (a) Bronchopneumonia
- (b) Hemiplegia
- (c) Cerebral infarction
- (d)
- 2

Both bronchopneumonia and hemiplegia can be caused by cerebral infarction. This means that cerebral infarction is the tentative starting point.

### Example 2

- 1 (a) Liver metastases 2 months
- (b) Bronchopneumonia 4 days
- (c) Stomach cancer 6 months
- (d)
- 2

Both liver metastases and bronchopneumonia can be caused by stomach cancer. This means that stomach cancer is the tentative starting point, even though bronchopneumonia cannot cause liver metastases and the bronchopneumonia has a shorter duration than the liver metastases.

### Example 3

- 1 (a) Liver metastases
  - (b) Bronchopneumonia
  - (c) Stomach cancer and cerebral infarction
  - (d)
- 2

Both liver metastases and bronchopneumonia can be caused by stomach cancer, which is the first condition mentioned on the lowest used line in Part 1. This means that stomach cancer is the tentative starting point.

### Example 4

- 1 (a) Liver metastases
  - (b) Bronchopneumonia and stomach cancer
  - (c)
  - (d)
- 2

Liver metastases cannot be due to bronchopneumonia. This means that no tentative starting point can be identified at Step SP3. Therefore, go to Step SP4.

#### 2.17.7 Step SP4 – Starting point of the first-mentioned sequence

The first-mentioned sequence is always found in Part 1 (see Section [2.16.5](#)).

- If one or more sequences ending with the terminal cause of death are reported in Part 1, identify the first-mentioned sequence (see Section [2.16.5](#)). The starting point of this sequence is the tentative starting point. Next go to Step SP6.

If no sequence ending with the terminal cause of death is reported in Part 1, go to Step SP5.

To assess causal relationship, refer to Section [2.16.2 Causal relationship and sequence](#), and to Section [2.19.1 Special instructions on accepted and rejected sequences \(Steps SP3 and SP4\)](#).

### Example 1

- 1 (a) Liver metastases
  - (b) Bronchopneumonia and stomach cancer
  - (c)
  - (d)
- 2

Bronchopneumonia cannot cause liver metastases (Step SP3 does not apply), but liver metastases can be due to stomach cancer. This is the first-mentioned sequence ending with the terminal cause of death, so stomach cancer is the tentative starting point.

### Example 2

- 1 (a) Bronchopneumonia
  - (b) Cerebral infarction and liver metastases
  - (c) Atherosclerosis and stomach cancer
  - (d)
- 2

Atherosclerosis cannot cause liver metastases (Step SP3 does not apply). There are three acceptable sequences on the certificate: (1) bronchopneumonia caused by cerebral infarction, in its turn caused by atherosclerosis; (2) bronchopneumonia caused by cerebral infarction, in its turn caused by stomach cancer; and (3) bronchopneumonia caused by liver metastases, in its turn caused by stomach cancer. The first-mentioned sequence is bronchopneumonia caused by cerebral infarction, in its turn caused by atherosclerosis. Consequently, atherosclerosis is the tentative starting point.

#### 2.17.8 Step SP5 – Terminal cause of death when no sequence

If no sequence ending with the terminal cause of death is reported in Part 1, the terminal cause of death is also the tentative starting point. Next, go to Step SP6.

### Example 1

- 1 (a) Liver metastases
  - (b) Cerebral infarction
  - (c) Atherosclerosis
  - (d)
- 2 Stomach cancer

Atherosclerosis cannot cause liver metastases (Step SP3 does not apply). Cerebral infarction cannot cause liver metastases (Step SP4 does not apply). No sequence ending with the terminal cause of death is reported in Part 1, so the terminal cause of death – liver metastases – is the tentative starting point.

#### 2.17.9 Step SP6 – Obvious cause

If the tentative starting point selected in Steps SP1 to SP5 was obviously caused by another condition on the certificate, select the obvious cause as the new tentative starting point. Conditions that are considered to have an ‘obvious’ causal relationship are specified in Section [2.19.2 Special instructions on obvious cause \(Step SP6\)](#). To identify which Part of the certificate you should search for, apply following rules:

- If the tentative starting point is in Part 1, the obvious cause must be either on the same or lower line, in Part 1, or in Part 2. Do not look for obvious causes on lines above the tentative starting point.
- If the tentative starting point is in Part 2, the obvious cause must also be in Part 2. Do not look for obvious causes in Part 1.

Next, reapply Step SP6 to the new tentative starting point. Continue looking for a new tentative starting point until you find a tentative starting point that is not obviously caused by a condition reported on the same line or further down on the certificate. Then go to Step SP7.

If there is no condition reported on the certificate that obviously caused the tentative starting point selected in Steps SP2 to SP5, go to Step SP7.

An obvious causal relationship is a type of causal relationship (see Section [2.19.1](#)) and a rejected sequence in Section [2.19.2] should also be rejected in considering an 'obvious' relationship between conditions. However, in considering accepting sequences, the word 'obviously' is important, and there must be no doubt about the relationship between the conditions. It is not sufficient that the sequence would have been accepted if the tentative starting point had been reported as due to the other condition. In applying Step SP6, always refer to Section [2.19.2](#).

Do not apply Step SP6 if the tentative starting point has a longer duration than the obvious cause.

If more than one obvious cause of the tentative starting point is reported, select the priority underlying condition (see Section [2.16.7](#)).

#### Example 1

- 1 (a) Sepsis  
(b) Peritonitis  
(c)  
(d)
- 2 Appendicitis with rupture

Sepsis can be caused by peritonitis, and peritonitis is the tentative starting point (Step SP3). Appendicitis with rupture is an obvious cause of peritonitis, and appendicitis with rupture is the new tentative starting point.

#### Example 2

- 1 (a) Liver metastases  
(b) Cerebral infarction  
(c)  
(d)
- 2 Stomach cancer

Cerebral infarction cannot cause liver metastases, and liver metastases is the tentative starting point (Step SP5). Stomach cancer is an obvious cause of liver metastases, and stomach cancer is the new tentative starting point.

#### Example 3

- 1 (a) Sepsis  
(b) Peritonitis, mesenteric embolism  
(c)  
(d)
- 2

Sepsis can be caused by peritonitis, and peritonitis is the tentative starting point (Step SP3). Mesenteric embolism is an obvious cause of peritonitis, and mesenteric embolism is the new tentative starting point.

#### Example 4

- 1 (a) Sepsis  
(b) Peritonitis  
(c)  
(d)
- 2 Mesenteric embolism, rupture appendicitis

Sepsis can be caused by peritonitis, and peritonitis is the tentative starting point (Step SP3). Next, both mesenteric embolism and ruptured appendicitis are obvious causes of peritonitis. Because mesenteric embolism is mentioned first and is the priority underlying condition, it is the new tentative starting point.

#### Example 5

- 1 (a) Sepsis  
(b) Peritonitis  
(c)  
(d)
- 2 Necrosis of intestine, mesenteric infarction

Sepsis can be caused by peritonitis, and peritonitis is the tentative starting point (Step SP3). Necrosis of intestine is an obvious cause of peritonitis, so necrosis of intestine is the new tentative starting point. Next, mesenteric infarction is an obvious cause of necrosis of intestine, and mesenteric infarction is the final starting point.

#### 2.17.10 Step SP7 – Ill-defined conditions

If the tentative starting point selected in Steps SP1 to SP6 is in the [List of ill-defined conditions](#), and:

- If there is at least one condition that is not ill-defined, then disregard the ill-defined condition. Go to Step SP1 and select another starting point, as if the ill-defined condition had not been mentioned on the certificate.
- If all other conditions reported on the certificate, are ill- defined, go to Step M1.

If the tentative starting point is not ill-defined, go to Step SP8.

Note that the following are not considered ill-defined:

#### [3.14.6 List of ill-defined conditions.](#)

#### Example 1

- 1 (a) Respiratory failure  
(b)  
(c)  
(d)
- 2 Mesenteric embolism

Respiratory failure is the only condition mentioned in Part 1 and it is the tentative starting point according to Steps SP2. Respiratory failure is in the table of ill-defined conditions, and there is a condition not ill-defined, Mesenteric embolism, so disregard respiratory failure and restart the selection procedure. Mesenteric embolism is the new starting point according to Step SP1.



### 2.17.11 Step SP8 – Conditions unlikely to cause death

If the tentative starting point selected in Steps SP1 to SP7 is in the [List of conditions unlikely to cause death](#) (see Mortality Annex [3.14.10](#), and:

- If all other conditions reported on the certificate are also unlikely to cause death or ill-defined, then keep this condition ‘unlikely to cause death’ as the starting point. Next, go to Step M1.
- If this condition was the cause of another condition that is not ‘unlikely to cause death’ and that is not ill-defined, then keep this condition unlikely to cause death as the starting point. Next, go to Step M1.
- If the death was caused by a reaction to treatment of the condition unlikely to cause death, select the reaction to treatment as the starting point. Next, go to Step M1
- If none of these three apply, and there is at least one condition that is not ‘unlikely to cause death’ and not ‘ill-defined’, then disregard the condition unlikely to cause death. Go to Step SP1 and select another starting point, as if the condition unlikely to cause death had not been mentioned on the certificate.

If the tentative starting point is not in the ‘List of conditions unlikely to cause death’, keep that condition as the starting point and go to Step M1.

If the certificate mentions more than one treatment for the condition unlikely to cause death, select the first-mentioned treatment.

#### Example 1

- 1 (a) Hearing loss  
(b)  
(c)  
(d)
- 2 Ischaemic heart disease

Hearing loss is the tentative starting point (Step SP2), but it is in the ‘List of conditions considered unlikely to cause death’. There is another condition on the certificate, ischaemic heart disease, which is not in the ‘List of conditions considered unlikely to cause death’. Disregard hearing loss and restart the selection procedure from Step SP1. Ischaemic heart disease is the new starting point (Step SP1).

#### Example 2

- 1 (a) Liver failure  
(b) Excessive use of paracetamol  
(c) Migraine-type headache  
(d)
- 2

Migraine type headache is the tentative starting point (Step SP3), but it is in the ‘List of conditions considered unlikely to cause death’. Migraine type headache was treated with paracetamol and there was a reaction to the treatment, liver failure. Select the reaction to the treatment, liver failure, as the starting point.

### Example 3

- 1 (a) Sepsis  
(b) Submandibular abscess  
(c) Caries  
(d)
- 2

Caries is the tentative starting point (Step SP3), but it is in the 'List of conditions considered unlikely to cause death'. In this case caries caused submandibular abscess, a condition that is not unlikely to cause death and that is not ill-defined. Because of that, keep caries as the starting point.

### Example 4

- 1 (a) Headache  
(b) Caries  
(c)  
(d)
- 2 Ischaemic heart disease

Caries is the tentative starting point (Step SP3), but it is in the 'List of conditions considered unlikely to cause death'. In this case caries caused headache, a condition that is in the list of ill-defined conditions. Disregard both caries (Step SP8) and headache (Step SP7) and restart the selection procedure from Step SP1. Ischaemic heart disease is the new starting point (Step SP1).

## 2.18 Check for modifications of the starting point (Steps M1 to M4)

The starting point identified using Steps SP1 to SP8 is now considered the tentative underlying cause. There may be special coding instructions on this tentative underlying cause, or other reasons to modify the tentative underlying cause. Check whether the tentative underlying cause should be modified by applying the modification rules described in steps M1 to M3 (Modification rule 1 to Modification rule 3). Each step contains one modification rule. At each step, there is a description of the modification rule itself and what to do next. There are also bullet points with more detailed instructions and explanations.

### 2.18.1 Step M1 – Special instructions

If the tentative underlying cause (TUC) selected in Steps SP1 to SP8 applies to a special instruction listed in Section [2.19.3 Special instructions on linkages and other provisions \(Step M1\)](#), assign a new tentative underlying cause according to the instruction.

Next, reapply Step M1 to the new tentative underlying cause. Repeat until you have found a tentative underlying cause that is not affected by any further special coding instruction. Next, go to Step M2.

If the tentative underlying cause does not apply to instructions in Section [2.19.3](#), go to Step M2.

If more than one instruction in Section [2.19.3](#) applies to the tentative underlying cause, select the instruction relating to the priority underlying condition (see Section [2.16.7](#)).

Note that there are two types of combinations of codes, 'with mention of' and 'when reported as a cause of'. Refer to Section [2.19.3](#) for details.

Sometimes the classification itself indicates a code for a combination of the tentative underlying cause with another cause mentioned on the certificate. Use the combination code unless an instruction on mortality coding in Section [2.19.3](#) indicates otherwise.

Examples of 'with mention of':

Example 1

- 1 (a) Myocardial infarction
- (b) Ischaemic heart disease
- (c)
- (d)

2

Ischaemic heart disease is the tentative starting point (Step SP3). There is a special instruction on ischaemic heart disease reported with mention of myocardial infarction, and, according to this instruction, myocardial infarction is the new tentative underlying cause.

Example 2

- 1 (a) Ischaemic heart disease
- (b) Atherosclerosis
- (c)
- (d)

2 Cerebral infarction

Atherosclerosis is the tentative starting point (Step SP3). There is a special instruction on 'atherosclerosis reported with ischaemic heart disease', and another one on 'atherosclerosis reported with cerebral infarction'. Ischaemic heart disease is the priority underlying condition, so apply the instruction on 'atherosclerosis reported with ischaemic heart disease' and select ischaemic heart disease as the new tentative underlying cause.

Example 3

- 1 (a) Cerebrovascular infarction
- (b) Atherosclerosis
- (c) Hypertension
- (d)

2 Myocardial infarction

Hypertension is the tentative starting point (Step SP3). There are special instructions on 'hypertension reported with mention of cerebrovascular infarction' and with myocardial infarction. Cerebrovascular infarction is the priority underlying condition, so apply the instruction on 'hypertension reported with mention of cerebrovascular infarction' and select cerebrovascular infarction as the new tentative underlying cause.

#### Example 4

- 1 (a) Ischaemic heart disease  
(b) Atherosclerosis  
(c)  
(d)
- 2 Myocardial infarction

Atherosclerosis is the tentative starting point (Step SP3). There is a special instruction on 'atherosclerosis reported with mention of ischaemic heart disease', and another one on 'atherosclerosis reported with mention of myocardial infarction'. Ischaemic heart disease is the priority underlying condition, so apply the instruction on 'atherosclerosis reported with mention of ischaemic heart disease' and select ischaemic heart disease as the new starting point. Next, there is a special instruction on 'ischaemic heart disease reported with mention of myocardial infarction'. Apply this instruction and select myocardial infarction as the new tentative underlying cause.

Examples of 'when reported as the cause of':

#### Example 5

- 1 (a) Chronic kidney disease  
(b) Atherosclerosis  
(c)  
(d)
- 2

Atherosclerosis is the tentative starting point (Step SP3). There is a special instruction on 'atherosclerosis reported as the cause of chronic kidney disease'. Apply this instruction and select hypertensive renal disease ([BA02](#)) as the new tentative underlying cause.

#### Example 6

- 1 (a) Atherosclerosis  
(b)  
(c)  
(d)
- 2 Chronic kidney disease

Atherosclerosis is the tentative starting point (Step SP2). Although there is a special instruction on 'atherosclerosis reported as the cause of chronic kidney disease', this instruction does not apply here because chronic kidney disease is reported in Part 2 and not as caused by atherosclerosis. In this case, atherosclerosis remains the tentative starting point.

### 2.18.2 Step M2 – Specificity

If the tentative underlying cause describes a condition in general terms and another term that provides more precise information about the site or nature of the same condition is reported on the certificate, use the more informative term. This rule will often apply when the general term becomes an adjective, qualifying the more precise term.

If the tentative underlying cause is an infectious disease reported as the cause of a specific manifestation, there may be a provision in the classification to combine the two codes into

one code providing more precise information about the site or nature of the tentative starting point. This code is the new tentative underlying cause of death.

Next, reapply Step M2 to the new tentative underlying cause. Repeat until you have found a tentative underlying cause that cannot be specified further.

- If there is no term that further specifies the tentative underlying cause (TUC), go to Step M3.
- If there are several other expressions that provide more precise information on the tentative underlying cause, select the priority underlying condition (see Section [2.16.7](#)).
- If the TUC is an unspecified condition and this condition appears with more specificity somewhere on the death certificate, this last more specific condition should be considered as the new TUC.

#### Example 1

- 1 (a) Meningitis [1D01.Z](#)  
(b) Tuberculosis [1B1Z](#)  
(c)  
(d)
- 2

Tuberculosis is the tentative starting point (Step SP3). A term providing more precise information about the site or nature of this condition is reported on the certificate: meningitis. There is a provision in the classification to combine the two codes, and according to instruction of step M2, tuberculous meningitis ([1B11.0](#)) is a new tentative underlying cause.

#### Example 2

- 1 (a) Syphilis, unspecified [1A6Z](#)  
(b)  
(c)  
(d)
- 2 Primary genital syphilis [1A61.0](#)

Syphilis, is the tentative starting point (Step SP2). A more specific condition for syphilis appears elsewhere on the death certificate: primary genital syphilis, and according to instruction of step M2, primary genital syphilis is a new tentative underlying cause.

#### Example 3

- 1 (a) Acute gastrointestinal bleeding [ME24.90](#)  
(b) Malignant neoplasms of colon, unspecified [2B90.Z](#)  
(c)  
(d)
- 2 Malignant neoplasm of transverse colon [2B90.2](#)

Malignant neoplasms of colon, is the tentative starting point (Step SP3). A more specific condition appears elsewhere on the death certificate: malignant neoplasm of transverse colon, and according to instruction of step M2, malignant neoplasm of transverse colon [2B90.2](#) is a new tentative underlying cause.

Regarding coding, this specificity can occur even between parents:

#### Example 4

- 1 (a) Sepsis without septic shock [1G40](#)
  - (b) Diabetes mellitus [5A14](#)
  - (c)
  - (d)
- 2 Type 1 diabetes mellitus [5A10](#)

Diabetes mellitus, type unspecified, is the tentative starting point (Step SP3). A more specific condition appears elsewhere on the death certificate: Type 1 diabetes mellitus, and according to instruction of step M2, Type 1 diabetes mellitus [5A10](#) is a new tentative underlying cause.

#### Example 5

- 1 (a) Stroke [8B20](#)
  - (b)
  - (c)
  - (d)
- 2 Intracerebral Haemorrhage [8B00](#)

Stroke, not known if ischaemic or haemorrhagic, is the tentative starting point (Step SP2). A term providing more precise information about the nature of this condition is reported on the certificate: intracerebral haemorrhage. According to instruction of step M2, intracerebral haemorrhage [8B00](#) is a new tentative underlying cause.

#### Example 6

- 1 (a) Acute pancreatitis [DC31.Z](#)
  - (b) Cytomegaloviral disease [1D82.Z](#)
  - (c)
  - (d)
- 2

Cytomegaloviral disease, unspecified, is the tentative starting point (Step SP3). The manifestation is described as acute pancreatitis, unspecified, and the two terms combine into cytomegaloviral pancreatitis ([1D82.1](#)), which is the new tentative underlying cause.

### 2.18.3 Step M3 – Recheck Steps SP6, M1 and M2

If, at this point, the tentative underlying cause is not the same as the starting point you selected in Steps SP1 to SP8, then go back to Step SP6. Repeat the procedures described in Steps SP6, M1 and M2.

If the tentative underlying cause is the same with the starting point selected in Step SP1 to SP8, go to Step M4.

- Do not go back to Step SP6 if the cause selected in Step M1 or M2 is correctly reported as due to another condition, except when this condition is ill-defined.
- Also, do not go back to Step SP6 if the tentative underlying cause is a reaction to treatment of a condition unlikely to cause death, as selected in Step SP8.

#### Example 1

- 1 (a) Sepsis
  - (b) Arterial disease, arterial embolism of left leg
  - (c)
  - (d)
- 2 Colon cancer

Arterial disease is the tentative starting point according to Step SP3. Arterial embolism of left leg, reported as the second condition on line 1(b), is a specific type of arterial disease. Therefore, select arterial embolism of left leg as the tentative underlying cause in Step M2. Reapply Step SP6, because the tentative starting point is not the same as the one selected in Steps SP1 to SP8. But colon cancer is an obvious cause of arterial embolism, and colon cancer is the new starting point. No further modifications apply. Code colon cancer ([2B90.Z](#)), Malignant neoplasms of colon, unspecified) as the underlying cause of death.

#### Example 1

- 1 (a) Sepsis
  - (b) Arterial disease, arterial embolism of left leg
  - (c) Atherosclerosis
  - (d)
- 2 Colon cancer

Atherosclerosis is the tentative starting point (Step SP3). There is a special instruction on 'atherosclerosis reported as the cause of arterial disease', and, according to this instruction, arterial disease is the new starting point according to Step M1. Arterial embolism of left leg, reported as the second condition on line 1(b), is a more specific description of the type of arterial disease and is selected as the tentative starting point in Step M2. Do not reapply Step SP6, because arterial embolism of left leg is reported as due to atherosclerosis, and this is a correct causal relationship. No further modifications apply. Code 'arterial embolism of left leg' as the underlying cause of death.

### 2.18.4 Step M4 - Instructions on medical procedures, main injury, poisoning, and maternal deaths

Finally, apply the following instructions to the tentative underlying cause selected by applying Steps SP1 to SP8 and Steps M1 to M3.

If the tentative underlying cause is:

- Surgery, another type of medical procedure, a complication or postprocedural condition, apply the instructions in Section [2.19.4 Special instructions on surgery and other medical procedures \(Step M4\)](#).
- In Chapter 22 'Injury, poisoning or certain other consequences of external causes', first code the external cause of the injury or poisoning as the underlying cause of

death. Also add the main injury to the cluster by following instructions in Section [2.19.5 Special instructions on main injury in deaths from external causes \(Step M4\)](#).

- In Chapter 23 'External causes of morbidity and mortality' also add the main injury to the cluster by following instructions in Section [2.19.5 Special instructions on main injury in deaths from external causes \(Step M4\)](#).
- Poisoning, use additional extension code from Section X (Extension Codes), if applicable, to identify the specific name of drug or toxic substance reported. If more than one drug or toxic substance is reported on the certificate, apply instructions in Section [2.19.6 Special instructions on poisoning by drugs, medications and biological substances \(Step M4\)](#), to identify the drug, medicament or substance most likely to have caused the death.

If the decedent is a woman, and pregnancy, childbirth or puerperium is reported on the certificate, determine whether to code the tentative underlying cause to Chapter 18 'Pregnancy, childbirth and the puerperium' according to the instructions in Section [2.19.7 Special instructions on maternal mortality \(Step M4\)](#).

When creating a cluster in Step M4, always put the code for the underlying cause of death at the beginning of the cluster.

After applying Step M4, the tentative underlying cause, modified or not, becomes the underlying cause of death.

If Step M4 does not apply, the tentative underlying cause becomes the underlying cause of death.

Note that other restrictions may apply, for example that the cause is limited to one of the sexes (see also Sections [2.21.7](#) and [3.14](#) (3.14.11 and 3.14.12)) or to a specific age range, or that the cause of death is improbable, considering the geographical setting. Therefore, always check whether any such restrictions apply to the underlying cause you selected.

## 2.19 Special instructions on selecting the underlying cause of death

The following sections are to be referred to in applying each instruction of Section [2.17.3](#) (Steps SP1 to SP8) and Section [2.18](#) (Steps M1 to M4).

### 2.19.1 Special instructions on accepted and rejected sequences (Steps SP3 and SP4)

This section lists sequences of causes of death that should be accepted or rejected when selecting the underlying cause of death. As described in Section [2.16.2 Causal relationship and sequence](#), these instructions are set with the aim of producing the most useful mortality statistics. Individual countries should not correct what is assumed to be an error, since changes at the national level will lead to data that are less comparable to data from other countries, and thus less useful for analysis.

A reported causal relationship not listed as rejected in this section should be accepted, as far as possible, because the certifier's opinion about the causes leading to death should not be disregarded lightly.

When applying Steps SP3 and SP4, reject the relationships listed in this section. Exceptions are listed as 'accept' in the table following each instruction.



Note that all information on causal relationship provided on the certificate should be considered. This applies also if the information appears in the 'wrong' place of the certificate. For example, if the sequence in Part 1 starts with a disease 'A', and information elsewhere on the certificate states that disease 'A' was due to a disease 'B', then consider 'B' as the tentative starting point. This also applies if disease 'A' and disease 'B' are coded to the same ICD-11 code and reported on separate lines of Part 1.

### 2.19.1.1 Conflicting durations

**Do not accept** a condition with a stated duration as due to a condition with a shorter duration.

#### **Consequence**

A condition with a stated duration

#### **Caused by**

**Do not accept** a condition with a shorter duration

When a duration of a condition is unknown or not stated assume the duration do not conflict, and do not reject a causal relationship by duration in such case.

### 2.19.1.2 Infectious diseases due to other conditions

#### *Cholera and certain infectious diseases due to other conditions*

**Do not accept** the following infectious and parasitic diseases as due to any other causes, **not even** human immunodeficiency virus (HIV) disease, malignant neoplasms or conditions impairing the immune system:

<b>Condition</b>	<b>Code</b>
<a href="#">1A00</a>	Cholera
<a href="#">1A11</a>	Botulism
<a href="#">1B20</a>	Leprosy
<a href="#">1B50</a>	Scarlet fever
<a href="#">1B91</a>	Leptospirosis
<a href="#">1B93</a>	Plague
<a href="#">1B94</a>	Tularaemia
<a href="#">1B95</a>	Brucellosis
<a href="#">1B97</a>	Anthrax
<a href="#">1C11.1</a>	Trench fever
<a href="#">1C12</a>	Whooping cough
<a href="#">1C13</a>	Tetanus
<a href="#">1C14</a>	Obstetrical tetanus
<a href="#">1C15</a>	Tetanus neonatorum
<a href="#">1C17</a>	Diphtheria
<a href="#">1C1C</a>	Meningococcal disease
<a href="#">1C22</a>	Infections due to Chlamydia psittaci
<a href="#">1C23.Z</a>	Trachoma
<a href="#">1C3Z</a>	Rickettsioses
<a href="#">1C80-1C8Z</a>	Viral infections of the central nervous system
<a href="#">1D20-1D2Z</a>	Dengue
<a href="#">1D47</a>	Yellow fever
<a href="#">1D40</a>	Chikungunya virus disease
<a href="#">1D42</a>	O'nyong-nyong fever
<a href="#">1D44</a>	Rift Valley fever
<a href="#">1D46</a>	West Nile virus infection
<a href="#">1D48</a>	Zika virus disease
<a href="#">1D49</a>	Crimean-Congo haemorrhagic fever
<a href="#">1D4A</a>	Omsk haemorrhagic fever
<a href="#">1D4B</a>	Kyasanur Forest disease
<a href="#">1D4C</a>	Alkhurma haemorrhagic fever
<a href="#">1D40-1D4Z</a>	Certain arthropod-borne viral fevers
<a href="#">1D60.0</a>	Ebola disease
<a href="#">1D60.1</a>	Marburg disease
<a href="#">1D61.0</a>	Argentinian haemorrhagic fever
<a href="#">1D61.1</a>	Bolivian haemorrhagic fever
<a href="#">1D61.2</a>	Lassa fever

<b>Condition</b>	<b>Code</b>
<a href="#">1D62.0</a>	Haemorrhagic fever with renal syndrome
<a href="#">1D65</a>	Severe acute respiratory syndrome
<a href="#">1D80</a>	Mumps
<a href="#">1D86</a>	Viral haemorrhagic fever, not elsewhere classified
<a href="#">1E30-1E32</a>	Influenza
<a href="#">1E50.1</a>	Acute hepatitis B
<a href="#">1E50.2</a>	Acute hepatitis C
<a href="#">1E51.0</a>	Chronic hepatitis B
<a href="#">1E51.1</a>	Chronic hepatitis C
<a href="#">1E51.2</a>	Chronic hepatitis D
<a href="#">1E70</a>	Smallpox
<a href="#">1E71</a>	Mpox (Monkeypox)
<a href="#">1F02</a>	Rubella
<a href="#">1F03</a>	Measles
<a href="#">1F40-1F4Z</a>	Malaria
<a href="#">1F51</a>	African trypanosomiasis
<a href="#">1F53</a>	Chagas disease
<a href="#">1F54</a>	Leishmaniasis
<a href="#">8A45.01</a>	Subacute sclerosing panencephalitis
<a href="#">8E02.0</a>	Genetic Creutzfeldt-Jakob disease
R -	Other emerging diseases reportable to WHO (e.g. <a href="#">RA01</a> .- COVID-19)

**Consequence condition**    **Causal condition**  
Cholera etc., listed above    **Do not accept** other causes

*Typhoid and certain infectious disease due to other conditions*

**Do not accept** the following infectious diseases as due to other causes, **except** HIV disease, malignant neoplasms and conditions impairing the immune system:

- [1A02](#) Intestinal infections due to Shigella
- [1A07](#) Typhoid fever
- [1A08](#) Paratyphoid fever
- [1A09](#) Infections due to other Salmonella
- [1B10-1B1Z](#) Tuberculosis

<b>Consequence condition</b>	<b>Causal condition</b>
Intestinal infections due to Shigella	<b>Accept</b> HIV disease, malignant neoplasms, and conditions impairing the immune system
Typhoid fever	<b>Do not accept</b> other causes
Paratyphoid fever	
Infections due to other Salmonella	
Tuberculosis	

### *HIV due to other conditions*

**Do not accept** HIV disease (1C60 - 1C62) as due to other conditions, **except**:

- conditions necessitating blood transfusion, such as haemophilia, anaemia and major injuries
- invasive procedures, such as surgery
- drug abuse

Examples of such conditions are given in the Mortality Annex [3.14](#). Note that the list in Mortality Annex [3.14](#) is not complete and should be considered indicative.

<b>Consequence condition</b>	<b>Causal condition</b>
HIV	<p><b>Accept</b></p> <ul style="list-style-type: none"> <li>- conditions necessitating blood transfusion, such as haemophilia, anaemia and major injuries</li> <li>- invasive procedures, such as surgery</li> <li>- drug abuse</li> </ul> <p>(for examples, refer to Mortality Annex <a href="#">3.14</a>.)</p> <p><b>Do not accept</b> other causes</p>

### *Infectious diseases not listed above due to other conditions*

Infectious diseases not listed above are accepted to be caused by other conditions.

<b>Consequence condition</b>	<b>Causal condition</b>
Infectious diseases not listed above	<b>Accept</b> other causes

### 2.19.1.3 Malignant neoplasms due to other conditions

**Do not accept** a malignant neoplasm as due to any other cause, except the following malignant neoplasms as due to HIV disease ([1C60](#) - [1C62](#)) :

- [2A60.5](#) Blastic plasmacytoid dendritic cell neoplasm, *specified as* primary in brain
- [2A80](#) Follicular lymphoma, *specified as* primary in brain
- [2A81](#) Diffuse large B-cell lymphomas, *specified as* immunoblastic
- [2A85.5](#) Mantle cell lymphoma, *specified as* primary in brain
- [2A85.6](#) Burkitt lymphoma including Burkitt leukaemia
- [2A86](#) B-cell lymphoma, mixed features, *specified as* primary in brain
- [2A87](#) Mature B-cell neoplasms, unspecified, *specified as* primary in brain
- [2A90-2B2Z](#) Mature T-cell or NK-cell neoplasms, *specified as* primary in brain
- [2B30](#) Hodgkin lymphoma, *specified as* primary in brain
- [2B57](#) Kaposi sarcoma, primary site
- [2B6A](#) Malignant neoplasms of oropharynx
- [2C00](#) Malignant neoplasms of anus or anal canal
- [2C70](#) Malignant neoplasms of vulva
- [2C71](#) Malignant neoplasms of vagina
- [2C77](#) Malignant neoplasms of cervix uteri, *specified as* invasive
- [2C81](#) Malignant neoplasms of penis

#### Consequence condition

Malignant neoplasm of oropharynx etc., listed above

Malignant neoplasms not listed above

#### Causal condition

**Accept** HIV diseases

**Do not accept** other causes

**Do not accept** other causes

### 2.19.1.4 Congenital or constitutional haemorrhagic condition due to other conditions

**Do not accept** congenital or constitutional haemorrhagic condition [3B10-3B1Z](#) as due to any other cause.

#### Consequence condition

Congenital or constitutional haemorrhagic condition

#### Causal condition

**Do not accept** other causes

### 2.19.1.5 Anaphylaxis due to external causes

**Do not accept** Anaphylaxis ([4A84](#)) as due to any other causes except Intentional self-harm ([PB80-PD3Z](#)) or Assault ([PD50-PF2Z](#)).

<b>Consequence</b>	<b>Caused by</b>
Anaphylaxis	<b>Accept</b> Intentional self-harm or Assault <b>Do not accept</b> other causes

### 2.19.1.6 Diabetes due to other conditions

**Do not accept** Type 1 diabetes mellitus as due to any other cause except conditions causing autoimmune destruction of beta-cells.

**Do not accept** Type 2 diabetes mellitus as due to any other cause except conditions causing insulin resistance.

**Do not accept** ‘Other and Unspecified diabetes mellitus’ as due to any other cause except conditions causing damage to the pancreas.

See Mortality Annex [3.14.8](#) for a list of the conditions that can cause diabetes.

<b>Consequence condition</b>	<b>Causal condition</b>
Type 1 diabetes mellitus	<b>Accept</b> conditions causing autoimmune destruction of beta cells <b>Do not accept</b> other causes
Type 2 diabetes mellitus	<b>Accept</b> conditions causing insulin resistance <b>Do not accept</b> other causes
Other and Unspecified diabetes mellitus	Accept conditions causing damage to the pancreas <b>Do not accept</b> other causes

### 2.19.1.7 Rheumatic fever due to other conditions

**Do not accept** Acute rheumatic fever (1B40-1B42), Heart valve diseases (BB60-BC0Z) with fifth character .0 rheumatic (if the fifth character is available), and [BC20](#) Chronic rheumatic heart diseases, not elsewhere classified due to other cause, except:

- [1B50](#) Scarlet fever
- [1B51](#) Streptococcal pharyngitis
- [CA03.0](#) Streptococcal tonsillitis

<b>Consequence condition</b>	<b>Causal condition</b>
Acute rheumatic fever	<b>Accept</b>
Rheumatic heart valve diseases	- Scarlet fever
Chronic rheumatic heart diseases NEC	- Streptococcal pharyngitis
	- Acute tonsillitis
	<b>Do not accept</b> other causes

### 2.19.1.8 Hypertension due to other conditions

**Do not accept** hypertensive conditions as due to a neoplasm, **except**:

- [Endocrine neoplasms](#)
- [Renal neoplasms](#)
- [Carcinoid tumours](#)

<b>Consequence condition</b>	<b>Causal condition</b>
Hypertensive conditions	<b>Accept</b>
	- endocrine neoplasms
	- renal neoplasms
	- carcinoid tumours
	<b>Do not accept</b> other neoplasms

### 2.19.1.9 Certain ischaemic heart disease due to other conditions

**Do not accept** Angina pectoris ([BA40](#)) and Chronic ischaemic heart disease ([BA50-BA5Z](#)) or Coronary atherosclerosis ([BA52](#)) as due to a neoplasm.

<b>Consequence condition</b>	<b>Causal condition</b>
Angina pectoris	<b>Accept</b> other causes
Chronic ischaemic heart disease	
Coronary atherosclerosis	<b>Do not accept</b> neoplasms

### 2.19.1.10 Atherosclerosis due to other conditions

**Do not accept** an atherosclerotic condition as due to a neoplasm.

<b>Consequence condition</b>	<b>Causal condition</b>
An atherosclerotic condition	<b>Accept</b> other causes
	<b>Do not accept</b> neoplasms

### 2.19.1.11 Developmental anomalies due to other conditions

**Do not accept** [Developmental anomalies] as due to any other cause, including immaturity, except:

- developmental anomalies due to a chromosome abnormality or a congenital malformation syndrome
- Congenital hypoplasia of lung ([LA75.2](#)) due to a congenital anomaly

<b>Consequence condition</b>	<b>Causal condition</b>
A developmental anomaly	<b>Accept</b> chromosome abnormality, congenital malformation syndrome <b>Do not accept</b> other causes, including immaturity
Congenital hypoplasia of lung	<b>Accept</b> a developmental anomaly <b>Do not accept</b> other causes, including immaturity

### 2.19.1.12 Unintentional cause of morbidity or mortality due to other conditions

**Do not accept** unintentional cause of morbidity or mortality as due to causes coded in other chapters, except:

- Fall or a fracture as due to a 'Certain specified disorders of bone density or structure' or 'Low bone mass disorders'
- Fall as due to a (pathological) fracture caused by 'Certain specified disorders of bone density or structure' or 'Low bone mass disorders'
- Inhalation or aspiration as due to other causes



**Consequence condition**

Unintentional cause of morbidity or mortality [PA00-PB6Z](#) *not listed below*

Fall [PA60-PA6Z](#)

[PB6Z](#) , *specified as fracture*

[PB04](#) Unintentional threat to breathing by inhalation or ingestion of gastric contents

[PB05](#) Unintentional threat to breathing by inhalation or ingestion of liquids

[PB06](#) Unintentional threat to breathing by inhalation or ingestion of food

[PB07](#) Unintentional threat to breathing by inhalation or ingestion of other objects or materials

**Causal condition**

**Do not accept** causes in other chapters

**Accept** [FB80](#) or [FB83](#)

**Accept** a (pathological) fracture caused by [FB80](#) or [FB83](#)

**Do not accept** other causes in other chapters

**Accept** [FB80](#) or [FB83](#)

**Do not accept** other causes in other chapters

**Accept** other causes

**Accept** other causes

**Accept** other causes

**Accept** other causes

**2.19.1.13 Suicide due to other conditions**

**Do not accept** suicide ([PB80-PD3Z](#)) as due to any other cause.

<b>Consequence condition</b>	<b>Causal condition</b>
Suicide	<b>Do not accept</b> other causes

**2.19.1.14 Obstetric conditions due to other conditions**

**Do not accept** Ectopic pregnancy ([JA01](#)) and Molar pregnancy ([JA02](#)) as due to other causes.

<b>Consequence condition</b>	<b>Causal condition</b>
<b>JA01</b> Ectopic pregnancy	<b>Do not accept</b> other causes
<b>JA02</b> Molar pregnancy	—

**Do not accept** Hypertensive disorders in pregnancy, childbirth, or the puerperium (JA20-21, JA23-JA25) as due to other causes.

**Consequence condition**

**JA20-JA21, JA23-JA25** Hypertensive disorders in pregnancy, childbirth, or the puerperium

**Causal condition**

**Do not accept** other causes

**Do not accept** Maternal care related to placenta praevia or low lying placenta ([JA8B](#)) as due to other causes.

**Consequence condition**

**JA8B** Maternal care related to placenta praevia or low lying placenta

**Causal condition**

**Do not accept** other causes

### 2.19.2 Special instructions on obvious cause (Step SP6)

This section lists conditions that should be considered an obvious cause of conditions selected as tentative starting point in Steps SP1 to SP5.

#### 2.19.2.1 Complications of HIV

##### *Infectious diseases and HIV*

Consider HIV disease ([1C60-1C62](#)) and ([MA14.0](#) *Laboratory evidence of human immunodeficiency virus*) as an obvious cause of infectious diseases:

- [1A32](#) Cryptosporidiosis
- [1A33](#) Cystoisosporiasis
- [1B21](#) Infections due to non-tuberculous mycobacteria
- [EA5Y](#) Cutaneous involvement by other specified bacterial infection
- [8A45.02](#) Progressive multifocal leukoencephalopathy
- Herpes simplex infection, of skin or mucous membrane ([1F00.0](#)), disseminated ([1F00.3](#)), other ([1F00.Y](#)) or unspecified ([1F00.Z](#)), *specified as* chronic ulcers, bronchitis, pneumonia, or oesophagitis
- [1D82](#) Cytomegaloviral disease, **except** Cytomegaloviral hepatitis ([1D82.0](#)), and **except for** liver, spleen, lymph nodes
- [1F23.2](#) Candidosis of gastrointestinal tract, *specified as* oesophagus
- [1F23.31](#) Pulmonary candidosis
- [1F25](#) Coccidioidomycosis
- [1F2A](#) Histoplasmosis
- [1F27](#) Cryptococcosis
- [CA40.20](#) Pneumonia due to pneumocystis

Consider HIV disease ([1C60 - 1C62](#)), but not [Laboratory evidence of human immunodeficiency virus] ([MA14.0](#)), as an obvious cause of infectious diseases (Chapter 01) not listed above, except those listed in Section ([2.19.1.2 Infectious diseases due to other conditions](#)).

### *Malignant neoplasms and HIV*

Consider both HIV disease ([1C60-1C62](#)) and Laboratory evidence of HIV ([MA14.0](#)) as obvious causes of the following malignant neoplasms:

- [2A80](#) Follicular lymphoma, *specified as primary in brain*
- [2A81](#) Diffuse large B-cell lymphomas, *specified as immunoblastic*
- [2A85.5](#) Mantle cell lymphoma, *specified as primary in brain*
- [2A85.6](#) Burkitt lymphoma including Burkitt leukaemia
- [2A86](#) B-cell lymphoma, mixed features, *specified as primary in brain*
- [2A87](#) Mature B-cell neoplasms, unspecified, *specified as primary in brain*
- [2B30](#) Hodgkin lymphoma, *specified as primary in brain*
- [2B57](#) Kaposi sarcoma, primary site
- [2C77](#) Malignant neoplasms of cervix uteri, *specified as invasive*

### *Immune deficiency and HIV*

Consider HIV disease ([1C60-1C62](#)) as an obvious cause of immune deficiency.

### *Pneumonia and HIV*

Consider HIV disease ([1C60-1C62](#)) as an obvious cause of pneumonia ([CA40](#)).

### *Cachexia and HIV*

Consider HIV disease ([1C60-1C62](#)) as an obvious cause of Cachexia, unspecified ([MG20.Z](#)).

## **2.19.2.2 Enterocolitis due to Clostridium difficile**

Consider enterocolitis due to Clostridium difficile ([1A04](#)) as an obvious consequence of ([Drugs, medicaments or biological substances associated with injury or harm in therapeutic use] ([P100](#)), *specified as antibiotic therapy*).

## **2.19.2.3 Sepsis**

Consider the following as obvious causes of sepsis ([1G40-1G41](#)):

- [Conditions that impair the immune system](#)
- [Wasting Diseases](#)
- [Diseases causing paralysis - sepsis](#)
- [Serious respiratory conditions](#)
- [Serious injuries](#) (grade 1–4 according to the injury priority list in the Mortality Annex ([3.14.5](#))).
- [Diseases of infectious origin](#) (this includes all the infections across the classification such as meningitis, peritonitis, osteomyelitis, pancreatitis, etc.)

## **2.19.2.4 Complications of diabetes**

Consider Diabetes mellitus ([5A10-5A14](#)) as an obvious cause of the following conditions:

- [5C73](#) Acidosis
- [8C0Z](#) Polyneuropathy, unspecified
- [8C12](#) Certain specified mononeuropathies
- [8C7Y](#) Other specified primary disorders of muscles, *specified as* amyotrophy but without specification of aetiology
- [8D8Z](#) Disorders of autonomic nervous system, unspecified
- [9A96.Z](#) Anterior uveitis, unspecified
- [9B10.Z](#) Cataract, unspecified
- [9B65.2](#)] Chorioretinal inflammation
- [9B74](#) Retinal vascular occlusions
- [9B78.1](#) Background retinopathy and retinal vascular changes
- [9B78.2](#) Other proliferative retinopathy
- [9B78.5](#) Retinal haemorrhage
- [9B7Z](#) Disorders of the retina, unspecified
- [BD40.0](#) Lower limb atherosclerosis
- [BD4Z](#) Chronic arterial occlusive disease, unspecified
- [EE80.1](#) Necrobiosis lipoidica
- [ME60.2](#) Ulcer of skin of uncertain nature, *specified as* lower limb
- [FA2Z](#) Inflammatory arthropathies, unspecified
- [MG30.5Z](#) Chronic neuropathic pain, unspecified
- [GB40](#) Nephritic syndrome
- [GB41](#) Nephrotic syndrome
- [GB42](#) Persistent proteinuria or albuminuria
- [GB61](#) Chronic kidney disease
- [GB6Z](#) Kidney failure, unspecified
- [MF54.0](#) Smooth contracted kidney
- [GC2Z](#) Diseases of the urinary system, unspecified, *specified as* kidney conditions
- [MC85](#) Gangrene
- [MB20.1](#) Coma
- [MA18.Y](#) Other specified abnormal findings of blood chemistry, *specified as* acetonæmia, azotaemia, or related conditions

#### 2.19.2.5 Dehydration

Consider any intestinal infectious disease as an obvious cause of Volume depletion ([5C70](#)).

#### 2.19.2.6 Dementia

Consider conditions that typically involve [irreversible brain damage] as obvious causes of dementia if no other cause of the dementia is stated. - [8B00-8B2Z](#) Cerebrovascular diseases (Exclusions : [8B10](#) Transient ischaemic attack and [8B21](#) Cerebrovascular disease with no acute cerebral symptom) - [8E44](#) Post anoxic brain damage - [8E40-8E4A.Z](#) Other specified disorders of the nervous system (inclusion terms) - [8B24.0](#) Anoxic-ischaemic encephalopathy - [KA40.0](#) Intracranial laceration or haemorrhage due to birth injury - [KA40.1](#)

Cerebral oedema due to birth injury - [KA40.Y](#) Other specified birth injury to central nervous system

Consider trisomy 21 (Down syndrome) ([LD40.0](#)) as an obvious cause of Dementia due to Alzheimer disease ([6D80](#)), Dementia, unknown or unspecified cause ([6D8Z](#)) or Alzheimer disease ([8A20](#)).

### 2.19.2.7 Disorders of intellectual development

Consider the following conditions as obvious causes of disorders of intellectual development ([6A00](#)):

- [8D64.2](#) Post haemorrhagic hydrocephalus, *specified as* neonatal
- [KA00-KA0Z](#) Fetus or newborn affected by maternal factors or by complications of pregnancy, labour or delivery
- [KA20](#) Disorders of newborn related to slow foetal growth or foetal malnutrition
- [KA21](#) Disorders of newborn related to short gestation or low birth weight, not elsewhere classified
- [KA40.0](#) Intracranial laceration or haemorrhage due to birth injury
- [KA40.1](#) Cerebral oedema due to birth injury
- [KA40.Z](#) Birth injury to central nervous system, unspecified
- [KA4Z](#) Birth injury, unspecified
- [KA61](#) Other bacterial infections of the newborn
- [KA62](#) Viral infection in the fetus or newborn
- [KA63](#) Fungal infection of fetus or newborn
- [KA64](#) Parasitic diseases in the fetus or newborn
- [KA6Y](#) Other specified infections of the fetus or newborn
- [KA6Z](#) Infections of the fetus or newborn, unspecified
- [KB20](#) Intrauterine hypoxia
- [KB21](#) Birth asphyxia
- [KA82](#) Intracranial nontraumatic haemorrhage of fetus or newborn
- [KA86](#) Neonatal kernicterus
- [KB00](#) Neonatal cerebral ischaemia
- [KB01](#) Periventricular cysts of newborn
- [KB02](#) Neonatal cerebral leukomalacia
- [KB03](#) Neonatal encephalopathy
- [KB04](#) Hypoxic ischaemic encephalopathy of newborn
- [KB05](#) Neonatal hydrocephalus
- [KB06](#) Neonatal seizures

### 2.19.2.8 Heart failure and unspecified heart disease

Consider other heart conditions as obvious causes of Diseases of the myocardium or cardiac chambers, unspecified ([BC4Z](#)) and Heart failure ([BD10-BD1Z](#)).

### 2.19.2.9 Embolism

Consider [Venous thrombosis](#), [Phlebitis or thrombophlebitis](#), [Valvular heart disease](#), [Childbirth](#) or any [Operation](#) as obvious causes of diseases described as ‘[Embolic](#)’. However, there must be a clear route from the place where the thrombus formed and the place of the embolism.

### 2.19.2.10 Oesophageal varices

Consider the following liver diseases as obvious causes of Oesophageal varices ([DA26.0](#)):

- [1E51](#) Chronic viral hepatitis
- [DB92](#) Non-alcoholic fatty liver disease
- [DB93](#) Hepatic fibrosis or cirrhosis
- [DB94](#) Alcoholic liver disease
- [DB96.1](#) Primary biliary cholangitis
- [DB97.2](#) Chronic hepatitis, not elsewhere classified
- [DB98.0](#) Infarction of liver
- [DB98.1](#) Peliosis hepatis
- [DB98.6](#) Hepatic veno-occlusive disease
- [DB98.7](#) Portal hypertension
- [DB98.8](#) Passive congestion of liver
- [DB99.2](#) Hepatorenal syndrome
- [DB99.Y](#) Other diseases of liver
- [DB9Z](#) Diseases of liver, unspecified

### 2.19.2.11 Pneumonia

Consider the following as obvious causes of Pneumonia ([CA40](#)) or Pneumonitis due to solids and liquids ([CA71](#)) except those due to oils or essences ([CA71.1](#)):

- [Conditions that impair the immune system](#)
- [Wasting Diseases](#)
- [Diseases causing paralysis](#)
- [Serious respiratory conditions](#)
- [Conditions that affect the process of swallowing](#)

Other diseases that limit the ability to care for oneself, including dementia and degenerative diseases of the nervous system, poisoning, and Other diseases that limit the ability to care for oneself, including dementia and degenerative diseases of the nervous system, poisoning, and [Serious injuries](#) (grade 1–4 according to the injury priority list in the Mortality Annex ([3.14.5](#))).

### 2.19.2.12 Pulmonary oedema

Consider the following conditions as obvious causes of Pulmonary oedema ([CB01](#)):

- heart disease (including pulmonary heart disease)
- conditions affecting the lung parenchyma, such as:
  - lung infections
  - aspiration and inhalation
  - respiratory distress syndrome
  - high altitude
  - circulating toxins
- conditions causing fluid overload, such as:
  - kidney failure
  - hypoalbuminaemia
- congenital anomalies affecting the pulmonary circulation, such as:
  - congenital stenosis of pulmonary veins

### 2.19.2.13 Nephritic syndrome

Consider any streptococcal infection (scarlet fever, streptococcal sore throat, etc.) as the obvious cause of Nephritic syndrome ([GB40](#)) or Nephrotic syndrome ([GB41](#)).

### 2.19.2.14 Pyelonephritis

Consider any urinary obstruction from conditions such as hyperplasia of prostate or ureteral stenosis as the obvious cause of the following Renal tubulo-interstitial diseases:

- [GB50](#) Acute tubulo-interstitial nephritis
- [GB51](#) Acute pyelonephritis
- [GB54](#) Tubulo-interstitial nephritis, not specified as acute or chronic
- [GB55.Y](#) Other specified chronic tubulo-interstitial nephritis
- [GB55.Z](#) Chronic tubulo-interstitial nephritis, unspecified

### 2.19.2.15 Acute renal failure

Consider a urinary tract infection as an obvious cause of Acute kidney failure ([GB60](#)), provided there is no indication that the renal failure was present before the urinary tract infection developed.

### 2.19.2.16 Primary atelectasis of newborn

Consider the following congenital kidney conditions, fetus or newborn affected by premature rupture of membranes ([KA01.1](#)) or by oligohydramnios ([KA01.2](#)) as obvious causes of Primary atelectasis of newborn ([KB2B](#)):

- [GB82](#) Autosomal dominant tubulointerstitial disease
- [GB8Y](#) Other specified cystic or dysplastic kidney disease
- [GB8Z](#) Cystic or dysplastic kidney disease, unspecified
- [LB31.8](#) Atresia or stenosis of ureter
- [LB31.9](#) Agenesis of ureter
- [LB31.Y](#) Other specified structural developmental anomalies of urinary tract
- [LD2F.13](#) Meckel-Gruber syndrome

#### 2.19.2.17 Premature rupture of membranes and oligohydramnios

Consider the following congenital kidney conditions as obvious causes of fetus or newborn affected by premature rupture of membranes ([KA01.1](#)) or by oligohydramnios ([KA01.2](#)):

- [GB82](#) Autosomal dominant tubulointerstitial disease
- [GB8Y](#) Other specified cystic or dysplastic kidney disease
- [GB8Z](#) Cystic or dysplastic kidney disease, unspecified
- [LB31.8](#) Atresia or stenosis of ureter
- [LB31.9](#) Agenesis of ureter
- [LB31.Y](#) Other specified structural developmental anomalies of urinary tract
- [LD2F.13](#) Meckel-Gruber syndrome

#### 2.19.2.18 Haemorrhage

Consider anticoagulant poisoning or overdose as obvious causes of haemorrhage. However, do not consider anticoagulant therapy, without mention of poisoning or overdose, as an obvious cause of haemorrhage. Further, consider treatment with steroid, aspirin, and nonsteroidal anti-inflammatory drugs (NSAIDs) as obvious causes of gastric haemorrhage ([ME24.Y](#)). Consider gastrointestinal haemorrhage ([ME24.9](#)) as an obvious cause of secondary ([3A00.0] ) or unspecified anaemia ([3A9Z] ).

#### 2.19.2.19 Aspiration and inhalation

Consider conditions listed under Section [2.19.2.11 Pneumonia](#), as obvious causes of aspiration and inhalation [PB04.-PB07](#).

#### 2.19.2.20 Surgery and other invasive medical procedures

Consider surgery or other invasive medical procedures, carried out within four weeks before death, as obvious causes of conditions that are considered common postprocedural complications. This applies also if the surgery or procedure is reported in a separate space on the certificate and not in Part 1 or Part 2.

A list of such conditions, with specific instructions, is given in Mortality Annex ([3.14.9 List of conditions to be considered obvious consequences of surgery and other invasive medical procedures](#)). If a condition that can be treated by surgery or other invasive medical procedures is reported on the certificate and surgery or a procedure of the same site is also reported on the certificate, then assume that this condition was the cause of the surgery or procedure.



### 2.19.2.21 Common secondary conditions

Consider the following as the obvious cause of the common secondary conditions listed in the table below:

- [Wasting Diseases](#) (such as malignant neoplasms and malnutrition)
- [Diseases causing paralysis](#) (such as cerebral haemorrhage or thrombosis)
- other disease that limits the ability to care for oneself, including dementia and degenerative diseases of the nervous system
- [Serious injuries](#) (grade 1-4 according to the injury priority list in the Mortality Annex [\(3.14.5\)](#))

However, do not consider respiratory conditions as the obvious cause of such secondary conditions.

Conditions in categories flagged with an 'M' (Maybe) should be considered obvious consequences of wasting and paralyzing conditions only if they meet the prerequisite for code assignment noted in the final column of the table.

#### **Common secondary conditions**

	<b>Consequence</b>	<b>Maybe</b>	<b>Qualifier</b>
<a href="#">3A00.0</a>	Acquired iron deficiency anaemia due to blood loss		
<a href="#">3A9Z</a>	Anaemias or other erythrocyte disorders, unspecified		
<a href="#">5B51</a>	Wasting in infants, children or adolescents		
<a href="#">5B52</a>	Acute malnutrition in infants, children or adolescents		
<a href="#">5B71</a>	Protein deficiency		
<a href="#">5B7Z</a>	Unspecified undernutrition		
<a href="#">5C70</a>	Volume depletion		
<a href="#">8B40</a>	Cauda equina syndrome		
<a href="#">8E45</a>	Locked-in syndrome		
<a href="#">BB00</a>	Pulmonary thromboembolism		
<a href="#">BD30.0</a>	Acute upper limb arterial occlusion		
<a href="#">BD30.2</a>	Acute lower limb arterial occlusion		
<a href="#">BD71.4</a>	Lower limb deep vein thrombosis		
<a href="#">BD71.Y</a>	Other specified deep vein thrombosis		
<a href="#">BD72</a>	Venous thromboembolism		
<a href="#">DA91.31</a>	Enterolith of small intestine		
<a href="#">DB30.3</a>	Impaction of large intestine		
<a href="#">DB30.2</a>	Acute mesenteric venous occlusion		
<a href="#">EH90</a>	Pressure ulceration		
<a href="#">GB50</a>	Acute tubulo-interstitial nephritis	M	Diseases causing paralysis or inability to control bladder
<a href="#">GB51</a>	Acute pyelonephritis	M	Diseases causing paralysis or inability to control bladder
<a href="#">GB55.Y</a>	Other specified chronic tubulo-interstitial nephritis	M	Diseases causing paralysis or inability to control bladder
<a href="#">GB55.Z</a>	Chronic tubulo-interstitial nephritis, unspecified	M	Diseases causing paralysis or inability to control bladder
<a href="#">GB54</a>	Tubulo-interstitial nephritis, not specified as acute or chronic	M	Diseases causing paralysis or inability to control bladder

	<b>Consequence</b>	<b>Maybe</b>	<b>Qualifier</b>
<a href="#">GB60-GB6Z</a>	Kidney failure	M	Diseases causing paralysis or inability to control bladder
<a href="#">GB90.3</a>	Ischaemia or infarction of kidney	M	The condition in <a href="#">GB90.3</a> must be specified as an embolism of the renal artery
<a href="#">GC00.1</a>	Infectious cystitis	M	Diseases causing paralysis or inability to control bladder
<a href="#">GC00.3</a>	Interstitial cystitis	M	Diseases causing paralysis or inability to control bladder
<a href="#">GC00.Z</a>	Cystitis, unspecified	M	Diseases causing paralysis or inability to control bladder
<a href="#">GC01.4</a>	Neuromuscular dysfunction of bladder, not elsewhere classified		
<a href="#">GC02.0</a>	Urethral abscess	M	Diseases causing paralysis or inability to control bladder
<a href="#">GC02.1</a>	Nonspecific urethritis	M	Diseases causing paralysis or inability to control bladder
<a href="#">GC02.Y</a>	Other specified urethritis and urethral syndrome	M	Diseases causing paralysis or inability to control bladder
<a href="#">GC03</a>	Urethral stricture	M	Diseases causing paralysis or inability to control bladder; Exclude post traumatic urethral strictures
<a href="#">GC08</a>	Urinary tract infection, site not specified	M	Diseases causing paralysis or inability to control bladder
<a href="#">MB50-MB5Z</a>	Paralytic symptoms		
<a href="#">ME05.0</a>	Constipation		
<a href="#">MG20.Z</a>	Cachexia, unspecified		

### 2.19.2.22 Secondary peritonitis

Consider the following conditions as obvious causes of Secondary peritonitis ([DC50.1](#)) and Peritonitis, unspecified ([DC50.Z](#)): [Secondary peritonitis and unspecified peritonitis](#)

### 2.19.3 Special instructions on linkages and other provisions (Step M1)

Use the list in this section in Step M1.

The tentative underlying cause is listed in the left-hand column. If the conditions specified in the right-hand column apply, then use the code in bold as the new tentative underlying cause. There are two types of combination:

'with mention of' means that the other condition may appear anywhere on the certificate;

'when reported as the cause of' means that the other condition must appear in a correct causal relationship or be otherwise indicated as being due to the tentative underlying cause.

For some conditions, there are further requirements, for example that a specific term has been used either for the tentative underlying cause or for the condition that may change the underlying cause code.

### **2.19.3.1 Special instructions on Chapter 01 Certain infectious or parasitic diseases**

**TUC is:**

[{01}(https://icd.who.int/browse/latest-release/mms/en#1435254666)] Chapter 1  
'Certain infectious or parasitic diseases'

**when reported as the cause of:**

[2A00-2A0Z](#)  
Neoplasms of brain or central nervous system

[2A20-2B3Z](#)  
Neoplasms of haematopoietic or lymphoid tissues

[2B50-2E2Z](#)  
Malignant neoplasms, **except** of lymphoid, haematopoietic, central nervous system or related tissues

**code to:**

[2A00-2A0Z](#)  
Neoplasms of brain or central nervous system

[2A20-2B3Z](#)  
Neoplasms of haematopoietic or lymphoid tissues

[2B50-2E2Z](#) Malignant neoplasms, except primary neoplasms of lymphoid, haematopoietic, central nervous system or related tissues

**Exception:**

[1C60.0](#) to [1C60.Z](#) Human immunodeficiency virus disease associated with tuberculosis

[1C61.0](#) to [1C61.Z](#) Human immunodeficiency virus disease associated with malaria

[1C62.0](#) to [1C62.Z](#) Human immunodeficiency virus disease without mention of tuberculosis or malaria

**when reported as the cause of:**

Malignant neoplasms listed at Section [2.19.2.1.2](#) 'Malignant neoplasms and HIV'

**code to:**

[1C60.3Z](#) HIV disease clinical stage 4 associated with tuberculosis, unspecified

[1C61.3Z](#) HIV disease clinical stage 4 associated with malaria, unspecified

[1C62.3Z](#) HIV disease clinical stage 4 without mention of tuberculosis or malaria

**TUC is:**

[1A61](#) Early syphilis

**with mention of:**

[1A62](#) Late syphilis

**code to:**

[1A62](#) Late syphilis

**TUC is:**

[1B10](#) Tuberculosis of the respiratory system

**with mention of:**

[CA60](#)  
Pneumoconiosis

**code to:**

[CA60.3](#)  
Pneumoconiosis associated with tuberculosis

<b>TUC is:</b>	<b>when reported as the cause of:</b>	<b>code to:</b>
<a href="#">1B11</a> Tuberculosis of the nervous system	<b>with mention of:</b> <a href="#">1B10</a> Tuberculosis of the respiratory system	<b>code to:</b> <a href="#">1B10</a> , unless <a href="#">1B12</a> is reported as the cause of <a href="#">1B10</a> and with a specified duration exceeding that of the condition in <a href="#">1B10</a> Tuberculosis of the respiratory system
<a href="#">1B12</a> Tuberculosis of other systems and organs		
<b>TUC is:</b> <a href="#">1C1C.2</a> Meningococcaemia	<b>with mention of:</b> <a href="#">1C1C.0</a> Meningococcal meningitis <a href="#">1C1C.1</a> Waterhouse-Friderichsen syndrome	<b>code to:</b> <a href="#">1C1C.0</a> Meningococcal meningitis <a href="#">1C1C.1</a> Waterhouse-Friderichsen syndrome
<b>TUC is:</b> <a href="#">1C41</a> Bacterial infection of unspecified site	<b>with mention of:</b> <a href="#">1G40</a> Sepsis without septic shock	<b>code to:</b> <a href="#">1G40</a> Sepsis without septic shock
<a href="#">1D9Z</a> Unspecified viral infection of unspecified site	<a href="#">1G41</a> Sepsis with septic shock	<a href="#">1G41</a> Sepsis with septic shock
<b>TUC is:</b> <a href="#">1E50.1</a> Acute hepatitis B	<b>when reported as the cause of:</b> <a href="#">DB93</a> Hepatic fibrosis or cirrhosis	<b>code to:</b> <a href="#">1E51.0Z</a> Chronic hepatitis B, unspecified
<a href="#">1E50.2</a> Acute hepatitis C	<a href="#">DB99.8</a> Chronic hepatic failure	<a href="#">1E51.1</a> Chronic hepatitis C
<a href="#">1E50.3</a> Acute hepatitis D		<a href="#">1E51.2</a> Chronic hepatitis D
<a href="#">1E50.4</a> Acute hepatitis E		<a href="#">1E51.3</a> Chronic hepatitis E

**TUC is:**

[1E50.Y](#) Other specified acute viral hepatitis

[1E50.Z](#) Acute viral hepatitis, unspecified

**when reported as  
the cause of:**

**code to:**

[1E51.Y](#) Other  
specified chronic viral  
hepatitis

[1E51.Z](#) Chronic viral  
hepatitis, unspecified

**TUC is:**

[1F2Z](#) Mycoses, unspecified

[1F5Z](#) Unspecified protozoal disease

[1H0Z](#) Infection, unspecified

**with mention of:**

[1G40](#) Sepsis  
without septic  
shock

[1G41](#) Sepsis with  
septic shock

**code to:**

[1G40](#) Sepsis without  
septic shock

[1G41](#) Sepsis with  
septic shock

*Human immunodeficiency virus disease*



**TUC is:**

[1A33](#) Cystoisosporiasis

[1D82](#) Cytomegaloviral disease

[1B21](#) Infections due to non-tuberculous mycobacteria

[1B2Y](#) Other specified mycobacterial diseases

[1B2Z](#) Mycobacterial diseases, unspecified

[1F00](#) Herpes simplex infections, **except** [1F00.Z](#)  
Herpes simplex infections, unspecified

[1F23.2](#) Candidosis of gastrointestinal tract

[1F23.31](#) Pulmonary candidosis

[1F25](#) Coccidioidomycosis

[1F27](#) Cryptococcosis

[1F2A](#) Histoplasmosis

[1F2G](#) Pneumocystosis

[1F57](#) Toxoplasmosis

**with mention of:**

[1C60-1C62.Z](#) Human immunodeficiency virus disease

[MA14.0](#) Laboratory evidence of HIV

**code to:**

[1C60](#).- Human immunodeficiency virus disease associated with tuberculosis to [1C60.3Y](#) Other specified HIV disease clinical stage 4 associated with tuberculosis

[1C62](#).- Human immunodeficiency virus disease without mention of tuberculosis or malaria to [1C62.3](#) HIV disease clinical stage 4 without mention of tuberculosis or malaria

Regardless of the subcode (5th to 6th character) that the TUC has, **code to** [1C60](#) Human immunodeficiency virus disease associated with tuberculosis - [1C62](#) Human immunodeficiency virus disease without mention of tuberculosis or malaria (changing the 5th character to number 3)

Use additional code if desired, to specify the individual associated condition reported.

TUC is:	with mention of:	code to:
<a href="#">2A60.5</a> Blastic plasmacytoid dendritic cell neoplasm, <b>specified as</b> primary cerebral		
<a href="#">2A80</a> Follicular lymphoma, <b>specified as</b> primary cerebral		
<a href="#">2A81</a> Diffuse large B-cell lymphomas, <b>specified as</b> immunoblastic		
<a href="#">2A85</a> Other specified mature B-cell neoplasms or lymphoma, <b>specified as</b> primary cerebral		
<a href="#">2A85.6</a> Burkitt lymphoma including Burkitt leukaemia		
<a href="#">2A86</a> B-cell lymphoma, mixed features, <b>specified as</b> primary cerebral		
<a href="#">2A90-2B2Z</a> Mature T-cell or NK-cell neoplasms, <b>specified as</b> primary cerebral ( <b>except</b> <a href="#">2B03</a> )		
<a href="#">2B30</a> Hodgkin lymphoma, <b>specified as</b> primary cerebral		
<a href="#">2B33</a> Malignant haematopoietic neoplasms without further specification, <b>specified as</b> primary cerebral		
<a href="#">2C77</a> Malignant neoplasms of cervix uteri		
<a href="#">8A45.02</a> Progressive multifocal leukoencephalopathy		
<a href="#">8E47</a> Encephalopathy, not elsewhere classified		
<a href="#">CA40.20</a> Pneumonia due to pneumocystis		
<a href="#">MG20.Z</a> Cachexia, unspecified		

**TUC is:**

[1C60-1C62.Z](#) Human immunodeficiency virus disease

**Note:** Modes of dying, ill-defined conditions and conditions unlikely to cause death should not be linked to categories in [1C60-1C62.Z](#) Human immunodeficiency virus disease unless the coding tool guides you

**Note:** Use additional code if desired, to specify the individual associated condition reported.

**TUC is:**

[1C60-1C62.Z](#) Human immunodeficiency virus disease

**with mention of:**

[1C60-1C62.Z](#) Human immunodeficiency virus disease, of a more severe stage with a fifth digit greater (except Z)

**code to:**

[1C60-1C62.Z](#) Human immunodeficiency virus disease, of a more severe stage use the highest fifth digit

**TUC is:**

[1B10-1B1Z](#)  
Tuberculosis

**with mention of:**

[1C62](#) Human immunodeficiency virus disease without mention of tuberculosis or malaria

**code to:**

[1C62.0](#) to [1C60.0](#); [1C62.1](#) to [1C60.1](#); [1C62.2](#) to [1C60.2](#); [1C62.3](#) to [1C60.3Z](#); [1C62.Z](#) to [1C60.Z](#); [MA14.0](#) to [1C60.Z](#)  
Regardless of the subcode (5th to 6th character) that the TUC has, code to [1C60](#) Human immunodeficiency virus disease associated with tuberculosis (respecting the 5th or 6th character if present). If the code in the second column is [MA14.0](#) code as [1C60.Z](#) Human immunodeficiency virus disease associated with tuberculosis, clinical stage unspecified

[1G80](#) Sequelae of tuberculosis

[MA14.0](#) Laboratory evidence of human immunodeficiency virus

[1C62](#) Human immunodeficiency virus disease without mention of tuberculosis or malaria

[1B10-1B1Z](#)  
Tuberculosis

[1C60](#) Human immunodeficiency virus disease associated with tuberculosis

[MA14.0](#) Laboratory evidence of human immunodeficiency virus

**TUC is:**

[1F40-1F4Z](#) Malaria

[1C62](#) Human immunodeficiency virus disease without mention of tuberculosis or malaria

[MA14.0](#) Laboratory evidence of human immunodeficiency virus

**with mention of:**

[1C62](#) Human immunodeficiency virus disease without mention of tuberculosis or malaria

[MA14.0](#) Laboratory evidence of human immunodeficiency virus

[1F40-1F4Z](#) Malaria

**code to:**

[1C61](#) Human immunodeficiency virus disease associated with malaria

[1C61](#) Human immunodeficiency virus disease associated with malaria

**TUC is:**

[2B57](#) Kaposi sarcoma, primary site

**with mention of:**

[1C60-1C62.Z](#) Human immunodeficiency virus disease

[MA14.0](#) Laboratory evidence of HIV

**code to:**

[1C60.30](#) Kaposi sarcoma associated with human immunodeficiency virus disease associated with tuberculosis

[1C61.30](#) Kaposi sarcoma associated with human immunodeficiency virus disease associated with malaria

[1C62.30](#) Kaposi sarcoma associated with human immunodeficiency virus disease without mention of tuberculosis or malaria

**TUC is:**

[{03}(https://icd.who.int/browse/latest-release/mms/en#1766440644)] Chapter 3 'Diseases of the blood or blood-forming organs'

**when reported as the cause of:**

[1C60-1C62.Z](#) Human immunodeficiency virus disease, and where the certificate indicates that the HIV disease is a result of a blood transfusion given treatment for the originating condition

**code to:**

[1C60-1C62.Z](#)  
Human immunodeficiency virus disease

[4A00-4A0Z](#) Primary immunodeficiencies

[4A20](#) Acquired immunodeficiencies

[4B00-4B0Z](#) Immune system disorders involving white cell lineages

[4B20-4B2Y](#) Certain disorders involving the immune system

[4B4Y](#) Other specified diseases of the immune system

[4B4Z](#) Diseases of the immune system, unspecified

### 2.19.3.2 Special instructions on Chapter 02 Neoplasms

**TUC is:**

[2E60-2E6Z](#) In situ neoplasms, **except** of lymphoid, haematopoietic, central nervous system or related tissues

**when reported as the cause of:**

metastatic spread, or if it is clear from other information on the certificate that the in situ neoplasm caused metastatic spread

If there is no indication that the in situ neoplasm caused metastatic spread,

**code to:**

the corresponding primary malignant neoplasm

Consider the in situ neoplasm unlikely to cause death, and **follow the instructions in Step SP8** Conditions unlikely to cause death.

### 2.19.3.3 Special instructions on Chapter 03 Diseases of the blood or blood-forming organs

### 2.19.3.4 Special instructions on Chapter 04 Diseases of the immune system

<b>TUC is:</b>	<b>with mention of:</b>	<b>code to:</b>	
<a href="#">4A84.Z</a> Anaphylaxis, unspecified	Exposure to or harmful effects of drugs, medicaments or biological substances:	<a href="#">NE60</a> Harmful effects <a href="#">PB20-PB29</a> Unintentional <a href="#">PH40-PH49</a> Undetermined intent, or <a href="#">PL00-PL0Z</a> Substances associated with injury or harm in therapeutic use]	<a href="#">4A84.1</a> Drug induced anaphylaxis Use additional extension code if desired, to identify the source agent.
	Exposure to or harmful effects of other or unspecified substances chiefly nonmedicinal as to source:	<a href="#">NE61</a> Harmful effects <a href="#">PB36</a> Unintentional <a href="#">PH56</a> Undetermined intent	<a href="#">4A84.0</a> Anaphylaxis due to allergic reaction to food, <a href="#">4A84.4</a> Anaphylaxis due to inhaled allergens, <a href="#">4A84.5</a> Anaphylaxis due to contact with allergens, or <a href="#">4A84.Y</a> Other specified anaphylaxis
	Stung or envenomated by animal:	<a href="#">PA78</a> Unintentional <a href="#">PG68</a> Undetermined intent	<a href="#">4A84.2</a> Anaphylaxis due to insect venom

### 2.19.3.5 Special instructions on Chapter 05 Endocrine, nutritional or metabolic diseases

<b>TUC is:</b>	<b>with mention of:</b>	<b>code to:</b>
<a href="#">5C70</a> Volume depletion	<a href="#">1A00-1A40.Z</a> Gastroenteritis or colitis of infectious origin	<a href="#">1A00-1A40.Z</a> Gastroenteritis or colitis of infectious origin

### 2.19.3.6 Special instructions on Chapter 06 Mental, behavioural or neurodevelopmental disorders

<p><b>TUC is:</b></p> <p><a href="#">6C40-6C4Z</a> Disorders due to substance use</p> <p><a href="#">6D72.1</a> Amnestic disorder due to psychoactive substances including medications</p>	<p><b>with mention of:</b></p> <p><a href="#">PB20-PB36</a> Unintentional exposure to or harmful effects of substances</p> <p><a href="#">PC90-PD05</a> Intentional self-harm by exposure to or harmful effects of substances</p> <p><a href="#">PE80-PE95</a> Assault by exposure to or harmful effects of substances</p> <p><a href="#">PH40-PH56</a> Exposure to or harmful effects of substances, undetermined intent</p>	<p><b>code to:</b></p> <p><a href="#">PB20-PB36</a> Unintentional exposure to or harmful effects of substances</p> <p><a href="#">PC90-PD05</a> Intentional self-harm by exposure to or harmful effects of substances</p> <p><a href="#">PE80-PE95</a> Assault by exposure to or harmful effects of substances</p> <p><a href="#">PH40-PH56</a> Exposure to or harmful effects of substances, undetermined intent</p>
--	---	---

<p><b>TUC is:</b></p> <p><a href="#">6C40-6C4Z</a> Disorders due to substance use, with fifth character .1 (if the fifth character is available) (harmful pattern of use)</p>	<p><b>with mention of:</b></p> <p><a href="#">6C40-6C4Z</a>, with fifth character .2 (dependence) (if the fifth character is available)</p> <p><a href="#">6C40-6C4Z</a>, with fifth character .5 (substance-induced delirium) (if the fifth character is available)</p> <p><a href="#">6D72.1</a> Amnestic disorder due to psychoactive substances including medications</p>	<p><b>code to:</b></p> <p><a href="#">6C40-6C4Z</a>, with fifth character .2 (if the fifth character is available)</p> <p><a href="#">6C40-6C4Z</a>, with fifth character .5 (if the fifth character is available)</p> <p><a href="#">6D72.1</a> Amnestic disorder due to psychoactive substances including medications</p>
---	---	---

<p><b>TUC is:</b></p> <p><a href="#">6C40-6C4Z</a> Disorders due to substance use, with fifth character .2 (dependence) (if the fifth character is available)</p>	<p><b>with mention of:</b></p> <p><a href="#">6C40-6C4Z</a>, with fifth character .5 (substance-induced delirium) (if the fifth character is available)</p> <p><a href="#">6D72.1</a> Amnestic disorder due to psychoactive substances including medications</p>	<p><b>code to:</b></p> <p><a href="#">6C40-6C4Z</a>, with fifth character .5 (if the fifth character is available)</p> <p><a href="#">6D72.1</a> Amnestic disorder due to psychoactive substances including medications</p>
---	--	---

**TUC is:**

[6C40-6C4Z](#) Disorders due to substance use, fifth character .6 (substance-induced psychotic disorder) (if the fifth character is available)

**with mention of:**

[6C40-6C4Z](#), with fifth character .2 (dependence) (if the fifth character is available)

[6C40-6C4Z](#), with fifth character .5 (substance-induced delirium) (if the fifth character is available)

[6D72.1](#) Amnestic disorder due to psychoactive substances including medications

**code to:**

[6C40-6C4Z](#), with fifth character .2 (if the fifth character is available)

[6C40-6C4Z](#), with fifth character .5 (if the fifth character is available)

[6D72.1](#) Amnestic disorder due to psychoactive substances including medications



<b>TUC is:</b>	<b>with mention of:</b>	<b>code to:</b>
<a href="#">6C40</a> Disorders due to use of alcohol	<a href="#">5A70.2</a> Pseudo-Cushing syndrome	<a href="#">5A70.2</a> Pseudo-Cushing syndrome
	<a href="#">8D44</a> Alcohol-related neurological disorders	<a href="#">8D44</a> Alcohol-related neurological disorders
	<a href="#">BC43.01</a> Nonfamilial dilated cardiomyopathy, specified as alcohol	<a href="#">BC43.01</a> Nonfamilial dilated cardiomyopathy, specified as alcohol
	<a href="#">DA42.80</a> Alcoholic gastritis	<a href="#">DA42.80</a> Alcoholic gastritis
<a href="#">6C40</a> Disorders due to use of alcohol	<a href="#">DB91.7</a> Acute or subacute hepatic failure, unspecified	<a href="#">DB94.7</a> Alcoholic liver disease, unspecified
	<a href="#">DB94.7</a> Alcoholic liver disease, unspecified	
	<a href="#">DB99.7</a> Hepatic failure without mention whether acute or chronic	
	<a href="#">DB99.8</a> Chronic hepatic failure	
	<a href="#">DB9Z</a> Diseases of liver, unspecified	
<a href="#">6C40</a> Disorders due to use of alcohol	<a href="#">DB92.Y</a> Other specified non-alcoholic fatty liver disease, not specified as non-alcoholic	<a href="#">DB94.0</a> Alcoholic fatty liver
	<a href="#">DB92.Z</a> Non-alcoholic fatty liver disease, unspecified, not specified as non-alcoholic	
<a href="#">6C40</a> Disorders due to use of alcohol	<a href="#">DB93.0</a> Hepatic fibrosis	<a href="#">DB94.2</a> Alcoholic liver fibrosis
<a href="#">6C40</a> Disorders due to use of alcohol	<a href="#">DB93.1</a> Hepatic cirrhosis	<a href="#">DB94.3</a> Alcoholic cirrhosis of liver without hepatitis
<a href="#">6C40</a> Disorders due to use of alcohol	<a href="#">DB97.2</a> Chronic hepatitis, not elsewhere classified	<a href="#">DB94.1</a> Alcoholic hepatitis
	<a href="#">DB97.Z</a> Inflammatory liver disease, unspecified	
<a href="#">6C40</a> Disorders due to use of alcohol	<a href="#">DC31.1</a> Acute alcohol-induced pancreatitis	<a href="#">DC31.1</a> Acute alcohol-induced pancreatitis
	<a href="#">DC31.Z</a> Acute pancreatitis, unspecified	<a href="#">DC31.1</a> Acute alcohol-induced pancreatitis

**TUC is:**

**with mention of:**

[DC32.Z](#) Chronic pancreatitis, unspecified, **except** when specified as due to other causes than alcohol

[DC32.3](#) Chronic alcohol-induced pancreatitis

[JA85.Y](#) Maternal care for known or suspected other specified fetal abnormality or damage, *specified as alcohol*

**code to:**

[DC32.3](#) Chronic alcohol-induced pancreatitis

[DC32.3](#) Chronic alcohol-induced pancreatitis

[JA85.Y](#) Maternal care for known or suspected other specified fetal abnormality or damage

<b>TUC is:</b>	<b>when reported as the cause of:</b>	<b>code to:</b>
<a href="#">6C40</a> Disorders due to use of alcohol	<a href="#">BC43.4</a> Cardiomyopathy due to drugs or other external agents	<a href="#">BC43.01</a> Nonfamilial dilated cardiomyopathy

### 2.19.3.7 Special instructions on Chapter 07 Sleep-wake disorders

### 2.19.3.8 Special instructions on Chapter 08 Diseases of the nervous system

### 2.19.3.9 Special instructions on Chapter 09 Diseases of the visual system

### 2.19.3.10 Special instructions on Chapter 10 Diseases of the ear or mastoid process

### 2.19.3.11 Special instructions on Chapter 11 Diseases of the circulatory system

<b>TUC is:</b>	<b>with mention of:</b>	<b>code to:</b>
<a href="#">BA00</a> Essential hypertension	<a href="#">8B00-8B2Z</a> Cerebrovascular diseases	<a href="#">8B00-8B2Z</a> Cerebrovascular diseases
	<a href="#">BA01</a> Hypertensive heart disease	<a href="#">BA01</a> Hypertensive heart disease
	<a href="#">BA02</a> Hypertensive renal disease	<a href="#">BA02</a> Hypertensive renal disease
	<a href="#">BA40-BA6Z</a> Ischaemic heart diseases	<a href="#">BA40-BA6Z</a> Ischaemic heart diseases
	<a href="#">BA81-BA8Z</a> Diseases of coronary artery	<a href="#">BA81-BA8Z</a> Diseases of coronary artery
	<a href="#">BD10-BD1Z</a> Heart failure, <a href="#">BC42.Z</a> Myocarditis, unspecified, <a href="#">BC45</a> Cardiomegaly, or <a href="#">BC4Z</a> Diseases of the myocardium or cardiac chambers, unspecified, <b>except</b> when specified as terminal/end stage or acute, sudden, or similar expressions of short duration (less than 24 hours)	<a href="#">BA01</a> Hypertensive heart disease

<b>TUC is:</b> <a href="#">BA00</a> Essential hypertension	<b>when reported as the cause of:</b> <a href="#">9B78.1</a> Background retinopathy and retinal vascular changes  <a href="#">BB60-BC0Z</a> Heart valve diseases, <b>except</b> fifth character .0 (rheumatic) (if the fifth character is available) or specified as rheumatic  <a href="#">GB40</a> Nephritic syndrome; <a href="#">GB41</a> Nephrotic syndrome; <a href="#">GB4Z</a> Glomerular diseases, unspecified; <a href="#">GB61</a> Chronic kidney disease; <a href="#">GB6Z</a> Kidney failure, unspecified; or <a href="#">MF54.0</a> Smooth contracted kidney	<b>code to:</b> <a href="#">9B78.1</a> Background retinopathy and retinal vascular changes  <a href="#">BB60-BC0Z</a> Heart valve diseases, <b>except</b> fifth character .0 (rheumatic) (if the fifth character is available) or specified as rheumatic  <a href="#">BA02</a> Hypertensive renal disease
---	---	--

<b>TUC is:</b> <a href="#">BA01</a> Hypertensive heart disease  <a href="#">BA02</a> Hypertensive renal disease	<b>with mention of:</b> <a href="#">BA40-BA6Z</a> Ischaemic heart diseases  <a href="#">BA81-BA8Z</a> Diseases of coronary artery	<b>code to:</b> <a href="#">BA40-BA6Z</a> Ischaemic heart diseases  <a href="#">BA81-BA8Z</a> Diseases of coronary artery
--	--	--

<b>TUC is:</b> <a href="#">BA40</a> Angina pectoris  <a href="#">BA4Z</a> Acute ischaemic heart disease, unspecified  <a href="#">BA50-BA5Z</a> Chronic ischaemic heart disease  <a href="#">BA6Z</a> Ischaemic heart diseases, unspecified	<b>with mention of:</b> <a href="#">BA41</a> Acute myocardial infarction  <a href="#">BA42</a> Subsequent myocardial infarction	<b>code to:</b> <a href="#">BA41</a> Acute myocardial infarction
--	--	---

[BA81-BA8Z] Diseases of coronary artery

<b>TUC is:</b> <a href="#">BC20.0</a> Rheumatic diseases of endocardium, valve unspecified <a href="#">BC20.1</a> ] Rheumatic heart disease, unspecified	<b>with mention of:</b> <a href="#">BB60-BC0Z</a> Heart valve diseases, with fifth character .0 (rheumatic) (if the fifth character is available)	<b>code to:</b> <a href="#">BB60-BC0Z</a> Heart valve diseases, with fifth character .0 (if the fifth character is available)
--	--	--

<b>TUC is:</b> <a href="#">BC60-BC9Z</a> Cardiac arrhythmia <a href="#">BC42.Z</a> Myocarditis, unspecified  <a href="#">BC45</a> Cardiomegaly  <a href="#">BC4Z</a> Diseases of the myocardium or cardiac chambers, unspecified <a href="#">BC45</a> Heart failure	<b>with mention of:</b> <a href="#">1F53</a> Chagas disease <a href="#">BA40-BA6Z</a> Ischaemic heart diseases <a href="#">BA81-BA8Z</a> Diseases of coronary artery	<b>code to:</b> <a href="#">1F53</a> Chagas disease <a href="#">BA40-BA6Z</a> Ischaemic heart diseases <a href="#">BA81-BA8Z</a> Diseases of coronary artery
--	---	---

<b>TUC is:</b> <a href="#">BC45</a> Heart failure, <b>except</b> when specified as terminal/end stage or acute, sudden, or similar expressions of short duration (less than 24 hours) <a href="#">BC4Z</a> Diseases of the myocardium or cardiac chambers, unspecified, <b>except</b> when specified as terminal/end stage or acute, sudden, or similar expressions of short duration (less than 24 hours)	<b>with mention of:</b> <a href="#">BA00</a> Essential hypertension <a href="#">BA01</a> Hypertensive heart disease	<b>code to:</b> <a href="#">BA01</a> Hypertensive heart disease <a href="#">BA01</a> Hypertensive heart disease
--	---	---

<b>TUC is:</b> <a href="#">BD1Z</a> Heart failure, unspecified  <a href="#">BC4Z</a> Diseases of the myocardium or cardiac chambers, unspecified	<b>with mention of:</b> <a href="#">CB01</a> Pulmonary oedema	<b>code to:</b> <a href="#">BD11.Z</a> Left ventricular failure, unspecified
---	--	---

<b>TUC is:</b>	<b>with mention of:</b>	<b>code to:</b>
<a href="#">BD40</a> Atherosclerotic chronic arterial occlusive disease	<a href="#">BA00</a> Essential hypertension	<a href="#">BA00</a> Essential hypertension
	<a href="#">BA01</a> Hypertensive heart disease	<a href="#">BA01</a> Hypertensive heart disease
	<a href="#">BA02</a> Hypertensive renal disease	<a href="#">BA02</a> Hypertensive renal disease
	<a href="#">BA03</a> Hypertensive crisis	<a href="#">BA03</a> Hypertensive crisis
	<a href="#">BA40-BA6Z</a> Ischaemic heart diseases	<a href="#">BA40-BA6Z</a> Ischaemic heart diseases
	[BA81-BA8Z] Diseases of coronary artery	[BA81-BA8Z] Diseases of coronary artery
	<a href="#">BC45</a> Heart failure	<a href="#">BC45</a> Heart failure
	<a href="#">BC42.Z</a> Myocarditis, unspecified	<a href="#">BC42.Y</a> Other specific myocarditis
	<a href="#">8B00-8B2Z</a> Cerebrovascular diseases	<a href="#">8B00-8B2Z</a> Cerebrovascular diseases

<b>TUC is:</b>	<b>when reported as the cause of:</b>	<b>code to:</b>
<a href="#">BD40</a> Atherosclerotic chronic arterial occlusive disease	<a href="#">BB60-BC0Z</a> Heart valve diseases, <b>except</b> fifth character .0 (rheumatic) (if the fifth character is available)	<a href="#">BB60-BC0Z</a> Heart valve diseases, <b>except</b> fifth character .0 (if the fifth character is available)
	<a href="#">BC4Z</a> Diseases of the myocardium or cardiac chambers, unspecified	<a href="#">BA52.Z</a> Coronary atherosclerosis, unspecified site
	<a href="#">BD30-BD5Z</a> Diseases of arteries or arterioles, <b>except</b> <a href="#">BD41</a> Non-atherosclerotic chronic arterial occlusive disease or <a href="#">BD53</a> Secondary disorders of arteries and arterioles	<a href="#">BD30-BD5Z</a> Diseases of arteries or arterioles, <b>except</b> <a href="#">BD41</a> Non-atherosclerotic chronic arterial occlusive disease or <a href="#">BD53</a> Secondary disorders of arteries and arterioles
	<a href="#">DD30-DD3Z</a> Ischaemic vascular disorders of intestine	<a href="#">DD30-DD3Z</a> Ischaemic vascular disorders of intestine
	<a href="#">MF54.0</a> Smooth contracted kidney	<a href="#">BA02</a> Hypertensive renal disease

<b>TUC is:</b> <a href="#">BD40.2</a> Atherosclerosis of renal artery	<b>when reported as the cause of:</b> <a href="#">GB40</a> Nephritic syndrome; <a href="#">GB41</a> Nephrotic syndrome; <a href="#">GB4Z</a> Glomerular diseases, unspecified; <a href="#">GB61</a> Chronic kidney disease; <a href="#">GB6Z</a> Kidney failure, unspecified; or <a href="#">MF54.0</a> Smooth contracted kidney	<b>code to:</b> <a href="#">BA02</a> Hypertensive renal disease
---	---	---

<b>TUC is:</b> <a href="#">BD40.Z</a> Atherosclerotic chronic arterial occlusive disease, unspecified	<b>with mention of:</b> <a href="#">MC85</a> Gangrene	<b>code to:</b> <a href="#">BD40.0</a> Lower limb atherosclerosis
--	---	--

<b>TUC is:</b> <a href="#">BD40.Z</a> Atherosclerotic chronic arterial occlusive disease, unspecified	<b>when reported as the cause of:</b> <a href="#">8A00.0</a> Parkinson disease  <a href="#">8A00.2Z</a> Secondary parkinsonism, unspecified  <a href="#">8A00.Z</a> Parkinsonism, unspecified  <a href="#">GB40</a> Nephritic syndrome; <a href="#">GB41</a> Nephrotic syndrome; <a href="#">GB4Z</a> Glomerular diseases, unspecified; <a href="#">GB61</a> Chronic kidney disease; <a href="#">GB6Z</a> Kidney failure, unspecified; or <a href="#">MF54.0</a> Smooth contracted kidney	<b>code to:</b> <a href="#">8A00.23</a> Vascular parkinsonism  <a href="#">8A00.23</a> Vascular parkinsonism  <a href="#">8A00.23</a> Vascular parkinsonism  <a href="#">BA02</a> Hypertensive renal disease
--	--	---

<b>TUC is:</b> <a href="#">BD50.3</a> Thoracic aortic aneurysm	<b>with mention of:</b> <a href="#">BD50.4</a> Abdominal aortic aneurysm	<b>code to:</b> <a href="#">BD50.5</a> Thoracoabdominal aortic aneurysm with the corresponding 6th character (perforation, rupture or without mention of perforation and rupture)
<a href="#">BD50.4</a> Abdominal aortic aneurysm	<a href="#">BD50.3</a> Thoracic aortic aneurysm	<a href="#">BD50.5</a> Thoracoabdominal aortic aneurysm with the corresponding 6th character (perforation, rupture or without mention of perforation and rupture)

<b>TUC is:</b> <a href="#">BD55</a> Asymptomatic stenosis of intracranial or extracranial artery	<b>with mention of:</b> <a href="#">8B00-8B2Z</a> Cerebrovascular diseases	<b>code to:</b> <a href="#">8B00-8B2Z</a> Cerebrovascular diseases
---	---	---

<b>TUC is:</b> <a href="#">BD55</a> Asymptomatic stenosis of intracranial or extracranial artery	<b>when reported as the cause of:</b> <a href="#">8A00.0</a> Parkinson disease <a href="#">8A00.2Z</a> Secondary parkinsonism, unspecified	<b>code to:</b> <a href="#">8A00.23</a> Vascular parkinsonism <a href="#">8A00.23</a> Vascular parkinsonism
---	--	---

### 2.19.3.12 Special instructions on Chapter 12 Diseases of the respiratory system

<b>TUC is:</b>  <a href="#">CA00</a> Acute nasopharyngitis  <a href="#">CA07</a> Acute upper respiratory infections of multiple and unspecified sites	<b>with mention of:</b>  <a href="#">MB44.3</a> Immobility	<b>code to:</b>  <a href="#">CA40.Z</a> Pneumonia, organism unspecified
---	--	---



<b>TUC is:</b>	<b>when reported as the cause of:</b>	<b>code to:</b>
<a href="#">CA00</a> Acute nasopharyngitis	<a href="#">1D01.Y</a> Other specified infectious meningitis not elsewhere classified	<a href="#">1D01.Y</a> Other specified infectious meningitis not elsewhere classified
<a href="#">CA07</a> Acute upper respiratory infections of multiple and unspecified sites	<a href="#">1D03.3</a> Intracranial abscess	<a href="#">1D03.3</a> Intracranial abscess
	<a href="#">1D04.1</a> Intracranial granuloma	<a href="#">1D04.1</a> Intracranial granuloma
	<a href="#">1E30-1E32</a> Influenza	<a href="#">1E30-1E32</a> Influenza
	<a href="#">AA80-AB0Z</a> Otitis media	<a href="#">AA80-AB0Z</a> Otitis media
	<a href="#">AB11</a> Mastoiditis or related conditions	<a href="#">AB11</a> Mastoiditis or related conditions
	<a href="#">CA20</a> Bronchitis	<a href="#">CA20</a> Bronchitis
	<a href="#">CA22</a> Chronic obstructive pulmonary disease (COPD)	<a href="#">CA22</a> Chronic obstructive pulmonary disease (COPD)
	<a href="#">CA27</a> Tracheobronchitis	<a href="#">CA27</a> Tracheobronchitis
	<a href="#">CA40</a> Pneumonia	<a href="#">CA40</a> Pneumonia
	<a href="#">CA41</a> Acute bronchiolitis	<a href="#">CA41</a> Acute bronchiolitis
	<a href="#">CA42</a> Acute bronchitis	<a href="#">CA42</a> Acute bronchitis
	<a href="#">GB40</a> Nephritic syndrome	<a href="#">GB40</a> Nephritic syndrome

<b>TUC is:</b>	<b>with mention of:</b>	<b>code to:</b>
<a href="#">CA42</a> Acute bronchitis	<a href="#">CA20.1</a> Chronic bronchitis	<a href="#">CA20.1</a> Chronic bronchitis
	<a href="#">CA22</a> Chronic obstructive pulmonary disease (COPD)	<a href="#">CA22</a> Chronic obstructive pulmonary disease (COPD)

<b>TUC is:</b>	<b>with mention of:</b>	<b>code to:</b>
<a href="#">CA20</a> Bronchitis	<a href="#">CA21</a> Emphysema	<a href="#">CA22</a> Chronic obstructive pulmonary disease
	<a href="#">CA22</a> Chronic obstructive pulmonary disease (COPD)	<a href="#">CA22</a> Chronic obstructive pulmonary disease (COPD)

<b>TUC is:</b>	<b>when reported as the cause of:</b>	<b>code to:</b>
<a href="#">CA20</a> Bronchitis	<a href="#">CA23</a> Asthma	<a href="#">CA22</a> Chronic obstructive pulmonary disease

Note: see also note below at [CA23](#)

<b>TUC is:</b>	<b>with mention of:</b>	<b>code to:</b>
<a href="#">CA22.Z</a> Chronic obstructive pulmonary disease, unspecified	<a href="#">CA40</a> Pneumonia	<a href="#">CA22.1</a> Certain specified chronic obstructive pulmonary disease
	<a href="#">CA41</a> Acute bronchiolitis	
	<a href="#">CA42</a> Acute bronchitis	

<b>TUC is:</b>	<b>with mention of:</b>	<b>code to:</b>
<a href="#">CA60</a> Pneumoconiosis	<a href="#">1B10</a> Tuberculosis of the respiratory system	<a href="#">CA60.3</a> Pneumoconiosis associated with tuberculosis

<b>TUC is:</b>	<b>with mention of:</b>	<b>code to:</b>
<a href="#">CB01</a> Pulmonary oedema	<a href="#">BD1Z</a> Heart failure, unspecified	<a href="#">BD11.Z</a> Left ventricular failure, unspecified
	<a href="#">BC4Z</a> Diseases of the myocardium or cardiac chambers, unspecified	

### 2.19.3.13 Special instructions on Chapter 13 Diseases of the digestive system

<b>TUC is:</b>	<b>with mention of:</b>	<b>code to:</b>
<a href="#">DB91.Z</a> Acute or subacute hepatic failure, unspecified	<a href="#">6C40</a> Disorders due to use of alcohol	<a href="#">DB94</a> Alcoholic liver disease
<a href="#">DB95</a> Drug-induced or toxic liver disease	<a href="#">DB94</a> Alcoholic liver disease	
<a href="#">DB99.7</a> Hepatic failure without mention whether acute or chronic	<a href="#">NE61</a> Harmful effects of or exposure to noxious substances, chiefly nonmedicinal as to source, not elsewhere classified, <i>specified as alcohol</i>	
<a href="#">DB99.8</a> Chronic hepatic failure		
<a href="#">DB9Z</a> Diseases of liver, unspecified		

**TUC is:** [DB92](#) Non-alcoholic fatty liver disease, **except** [DB92.1](#) Non-alcoholic steatohepatitis

**with mention of:** [6C40](#) Disorders due to use of alcohol

**code to:** [DB94.0](#)  
Alcoholic fatty liver

[DB94](#) Alcoholic liver disease  
[NE61](#) Harmful effects of or exposure to noxious substances, chiefly nonmedicinal as to source, not elsewhere classified, *specified as* alcohol

**TUC is:** [DB92.1](#) Non-alcoholic steatohepatitis

**with mention of:** [6C40](#) Disorders due to use of alcohol

**code to:** [DB94.1](#)  
Alcoholic hepatitis

[DB97.2](#) Chronic hepatitis, not elsewhere classified

[DB94](#) Alcoholic liver disease

[DB97.Z](#) Inflammatory liver disease, unspecified

[NE61](#) Harmful effects of or exposure to noxious substances, chiefly nonmedicinal as to source, not elsewhere classified, *specified as* alcohol

**TUC is:** [DB93](#) Hepatic fibrosis or cirrhosis, **except** [DB93.0](#) Hepatic fibrosis

**with mention of:** [6C40](#) Disorders due to use of alcohol

**code to:** [DB94.3](#) Alcoholic cirrhosis of liver without hepatitis

[DB94](#) Alcoholic liver disease  
[NE61](#) Harmful effects of or exposure to noxious substances, chiefly nonmedicinal as to source, not elsewhere classified, *specified as* alcohol

<b>TUC is:</b> <a href="#">DB93.0</a> Hepatic fibrosis	<b>with mention of:</b> <a href="#">6C40</a> Disorders due to use of alcohol  <a href="#">DB94</a> Alcoholic liver disease <a href="#">NE61</a> Harmful effects of or exposure to noxious substances, chiefly nonmedicinal as to source, not elsewhere classified, <i>specified as</i> alcohol	<b>code to:</b> <a href="#">DB94.2</a> Alcoholic liver fibrosis
---	--	--

<b>TUC is:</b> <a href="#">DC31.Z</a> Acute pancreatitis, unspecified  <a href="#">DC32.Z</a> Chronic pancreatitis, unspecified, <b>except</b> when specified as due to other causes than alcohol	<b>with mention of:</b> <a href="#">6C40</a> Disorders due to use of alcohol  <a href="#">6C40</a> Disorders due to use of alcohol	<b>code to:</b> <a href="#">DC31.1</a> Acute alcohol-induced pancreatitis  <a href="#">DC32.3</a> Chronic alcohol-induced pancreatitis
--	---	---

#### 2.19.3.14 Special instructions on Chapter 14 Diseases of the skin

<b>TUC is:</b> <a href="#">EH90</a> Pressure ulceration	<b>when reported as the cause of:</b> <a href="#">EH90</a> Pressure ulceration, of a more advanced stage	<b>code to:</b> <a href="#">EH90</a> Pressure ulceration, of a more advanced stage
--	---	---

#### 2.19.3.15 Special instructions on Chapter 15 Diseases of the musculoskeletal system or connective tissue

#### 2.19.3.16 Special instructions on Chapter 16 Diseases of the genitourinary system

<b>TUC is:</b> <a href="#">GB61</a> Chronic kidney disease	<b>when reported as the cause of:</b> <a href="#">GB61</a> Chronic kidney disease, of a more advanced stage	<b>code to:</b> <a href="#">GB61</a> Chronic kidney disease, of a more advanced stage
---	--	--

<b>TUC is:</b>	<b>with mention of:</b>	<b>code to:</b>
<a href="#">GB61</a> Chronic kidney disease	<a href="#">BA00.Z</a> Essential hypertension, unspecified	<a href="#">BA02</a> Hypertensive renal disease
<a href="#">GB67</a> Kidney failure, unspecified	<a href="#">BA02</a> Hypertensive renal disease	<a href="#">BA02</a> Hypertensive renal disease
<a href="#">MF54.0</a> Smooth contracted kidney		

### 2.19.3.17 Special instructions on Chapter 17 Conditions related to sexual health

### 2.19.3.18 Special instructions on Chapter 18 Pregnancy, childbirth or the puerperium

<b>TUC is:</b>	<b>with mention of:</b>	<b>code to:</b>
<a href="#">JA24</a> Pre-eclampsia	<a href="#">JA25</a> Eclampsia	<a href="#">JA25</a> Eclampsia

<b>TUC is:</b>	<b>with mention of:</b>	<b>code to:</b>
<a href="#">JA82</a> Maternal care for known or suspected malpresentation of fetus	<a href="#">JA83</a> Maternal care for known or suspected disproportion	<a href="#">JA83</a> Maternal care for known or suspected disproportion

<b>TUC is:</b>	<b>with mention of:</b>	<b>code to:</b>
<a href="#">JA83.Z</a> Maternal care for known or suspected disproportion, unspecified	<a href="#">JA83.0</a> Maternal care for disproportion due to deformity of maternal pelvic bones	<a href="#">JA83.0</a> Maternal care for disproportion due to deformity of maternal pelvic bones
	<a href="#">JA83.1</a> Maternal care for disproportion due to generally contracted pelvis	<a href="#">JA83.1</a> Maternal care for disproportion due to generally contracted pelvis
	<a href="#">JA83.2</a> Maternal care for disproportion due to inlet contraction of pelvis	<a href="#">JA83.2</a> Maternal care for disproportion due to inlet contraction of pelvis
	<a href="#">JA83.3</a> Maternal care for disproportion due to outlet contraction of pelvis	<a href="#">JA83.3</a> Maternal care for disproportion due to outlet contraction of pelvis

<b>TUC is:</b>	<b>with mention of:</b>	<b>code to:</b>
<a href="#">JB04</a> Obstructed labour due to malposition or malpresentation of fetus	<a href="#">JB05</a> Obstructed labour due to maternal pelvic abnormality	<a href="#">JB05</a> Obstructed labour due to maternal pelvic abnormality

<b>TUC is:</b>	<b>when reported as the cause of:</b>	<b>code to:</b>
<a href="#">JA61.0</a> Varicose veins of lower extremity in pregnancy	<a href="#">JB42.2</a> Obstetric blood-clot embolism	<a href="#">JB42.2</a> Obstetric blood-clot embolism
<a href="#">JA61.1</a> Genital varices in pregnancy		
<a href="#">JA61.2</a> Superficial thrombophlebitis in pregnancy		
<a href="#">JA61.4</a> Haemorrhoids in pregnancy		

<b>TUC is:</b>	<b>when reported as the cause of:</b>	<b>code to:</b>
<a href="#">JA65.2</a> Excessive weight gain in pregnancy	<a href="#">JA20-JA2Z</a> Oedema, proteinuria, or hypertensive disorders in pregnancy, childbirth, or the puerperium	<a href="#">JA20-JA2Z</a> Oedema, proteinuria, or hypertensive disorders in pregnancy, childbirth, or the puerperium

<b>TUC is:</b>	<b>with mention of:</b>	<b>code to:</b>
<a href="#">JA65.3</a> Low weight gain in pregnancy	<a href="#">JB64.2</a> Endocrine, nutritional or metabolic diseases complicating pregnancy, childbirth or the puerperium	<a href="#">JB64.2</a> Endocrine, nutritional or metabolic diseases complicating pregnancy, childbirth or the puerperium

<b>TUC is:</b>	<b>when reported as the cause of:</b>	<b>code to:</b>
<a href="#">JA65.4</a> Pregnancy care of habitual aborter	<a href="#">JA00-JA0Z</a> Abortive outcome of pregnancy	<a href="#">JA00-JA0Z</a> Abortive outcome of pregnancy
<a href="#">JA65.5</a> Retained intrauterine contraceptive device in pregnancy	<a href="#">JA00-JA0Z</a> Abortive outcome of pregnancy	<a href="#">JA00-JA0Z</a> Abortive outcome of pregnancy
	<a href="#">JA88.1</a> Infection of amniotic sac and membranes	<a href="#">JA88.1</a> Infection of amniotic sac and membranes
	<a href="#">JB00</a> Preterm labour or delivery	<a href="#">JB00</a> Preterm labour or delivery

<b>TUC is:</b> <a href="#">JA65.7</a> Subluxation of symphysis pubis in pregnancy, childbirth or the puerperium  <a href="#">JA65.7</a> Subluxation of symphysis pubis in pregnancy, childbirth or the puerperium	<b>with mention of:</b> <a href="#">JB04</a> - <a href="#">JB06</a> Obstructed labour due to malposition or malpresentation of fetus, maternal pelvic abnormality or due to other causes  <a href="#">JB04</a> - <a href="#">JB06</a> Obstructed labour due to malposition or malpresentation of fetus, maternal pelvic abnormality or due to other causes	<b>code to:</b> <a href="#">JB04</a> - <a href="#">JB06</a> Obstructed labour due to malposition or malpresentation of foetus, maternal pelvic abnormality, or other causes  <a href="#">JB04</a> - <a href="#">JB06</a> Obstructed labour due to malposition or malpresentation of foetus, maternal pelvic abnormality, or other causes
--	---	---

<b>TUC is:</b>  <a href="#">JA67.4</a> Spinal and epidural anaesthesia-induced headache during pregnancy	<b>when reported as the cause of:</b>  <a href="#">JA67.2</a> Central nervous system complications of anaesthesia during pregnancy	<b>code to:</b>  <a href="#">JA67.2</a> Central nervous system complications of anaesthesia during pregnancy
--	--	--

<b>TUC is:</b>  <a href="#">JA80</a> Maternal care related to multiple gestation  <a href="#">JA81</a> Maternal care related to complications specific to multiple gestation	<b>when reported as the cause of:</b>  <a href="#">JB04</a> - <a href="#">JB06</a> Obstructed labour due to malposition or malpresentation of foetus, maternal pelvic abnormality, or other causes  <a href="#">JB0D.3</a> Other complications of obstetric surgery or procedures  <a href="#">JB42.1</a> Amniotic fluid embolism	<b>code to:</b>  <a href="#">JB04</a> - <a href="#">JB06</a> Obstructed labour due to malposition or malpresentation of foetus, maternal pelvic abnormality, or other causes  <a href="#">JB0D.3</a> Other complications of obstetric surgery or procedures  <a href="#">JB42.1</a> Amniotic fluid embolism
--	---	---

<b>TUC is:</b>	<b>when reported as the cause of:</b>	<b>code to:</b>
<a href="#">JA82</a> Maternal care for known or suspected malpresentation of fetus	<a href="#">JA43</a> Postpartum haemorrhage	<a href="#">JA43</a> Postpartum haemorrhage
<a href="#">JA83</a> Maternal care for known or suspected disproportion	<a href="#">JB04</a> - <a href="#">JB06</a> Obstructed labour due to malposition or malpresentation of foetus, maternal pelvic abnormality, or other causes	<a href="#">JB04</a> - <a href="#">JB06</a> Obstructed labour due to malposition or malpresentation of foetus, maternal pelvic abnormality, or other causes
<a href="#">JA84</a> Maternal care for known or suspected abnormality of pelvic organs	<a href="#">JB09</a> - <a href="#">JB0A</a> Perineal laceration during delivery and other obstetric trauma	<a href="#">JB09</a> - <a href="#">JB0A</a> Perineal laceration during delivery and other obstetric trauma
<a href="#">JA85</a> Maternal care for known or suspected fetal abnormality or damage	<a href="#">JB0D</a> Certain specified complications of labour or delivery, not elsewhere classified	<a href="#">JB0D</a> Certain specified complications of labour or delivery, not elsewhere classified
<a href="#">JA86</a> Maternal care for other known or suspected fetal problems	<a href="#">JB40</a> Infections in the puerperium	<a href="#">JB40</a> Infections in the puerperium

<b>TUC is:</b>	<b>when reported as the cause of:</b>	<b>code to:</b>
<a href="#">JA87</a> Maternal care related to polyhydramnios	<a href="#">JA8C</a> Maternal care related to premature separation of placenta	<a href="#">JA8C</a> Maternal care related to premature separation of placenta
	<a href="#">JB03</a> Long labour	<a href="#">JB03</a> Long labour
	<a href="#">JB04</a> - <a href="#">JB06</a> Obstructed labour due to malposition or malpresentation of foetus, maternal pelvic abnormality, or other causes	<a href="#">JB04</a> - <a href="#">JB06</a> Obstructed labour due to malposition or malpresentation of foetus, maternal pelvic abnormality, or other causes
	<a href="#">JA43</a> Postpartum haemorrhage	<a href="#">JA43</a> Postpartum haemorrhage
	<a href="#">JB0D</a> Certain specified complications of labour or delivery, not elsewhere classified	<a href="#">JB0D</a> Certain specified complications of labour or delivery, not elsewhere classified
	<a href="#">JB40</a> Infections in the puerperium	<a href="#">JB40</a> Infections in the puerperium
	<a href="#">JB42.1</a> Amniotic fluid embolism	<a href="#">JB42.1</a> Amniotic fluid embolism



**TUC is:**

[JA88.0](#) Oligohydramnios

[JA88.Y](#), [JA88.Z](#) Other specified disorders of amniotic fluid and membranes and Disorders of amniotic fluid and membranes, unspecified

**when reported as the cause of:**

[JA43](#) Postpartum haemorrhage

[JA88.1](#) Infection of amniotic sac or membranes

[JB03](#) Long labour

[JB40](#) Infections in the puerperium

[JB0D](#) Certain specified complications of labour or delivery, not elsewhere classified

**code to:**

[JA43](#) Postpartum haemorrhage

[JA88.1](#) Infection of amniotic sac or membranes

[JB03](#) Long labour

[JB40](#) Infections in the puerperium

[JB0D](#) Certain specified complications of labour or delivery, not elsewhere classified

**TUC is:**

[JA89.3](#) Premature rupture of membranes

**when reported as the cause of:**

[JA88.1](#) Infection of amniotic sac or membranes

[JB03](#) Long labour

[JA43](#) Postpartum haemorrhage

[JB0D](#) Certain specified complications of labour or delivery, not elsewhere classified

[JB40](#) Infections in the puerperium

[JB42.1](#) Amniotic fluid embolism

**code to:**

[JA88.1](#) Infection of amniotic sac or membranes

[JB03](#) Long labour

[JA43](#) Postpartum haemorrhage

[JB0D](#) Certain specified complications of labour or delivery, not elsewhere classified

[JB40](#) Infections in the puerperium

[JB42.1](#) Amniotic fluid embolism

<b>TUC is:</b>	<b>when reported as the cause of:</b>	<b>code to:</b>
<a href="#">JA8A.0</a> Placental transfusion syndromes	<a href="#">JA8C</a> Maternal care related to premature separation of placenta	<a href="#">JA8C</a> Maternal care related to premature separation of placenta
<a href="#">JA8A.1</a> Malformation of placenta	<a href="#">JA42</a> Intrapartum haemorrhage	<a href="#">JA42</a> Intrapartum haemorrhage
<a href="#">JA8A.Y</a> Other specified maternal care related to placental disorders	<a href="#">JA43</a> Postpartum haemorrhage	<a href="#">JA43</a> Postpartum haemorrhage
<a href="#">JA8A.Z</a> Maternal care related to placental disorders, unspecified	<a href="#">JB0D</a> Certain specified complications of labour or delivery, not elsewhere classified	<a href="#">JB0D</a> Certain specified complications of labour or delivery, not elsewhere classified
	<a href="#">JB40</a> Infections in the puerperium	<a href="#">JB40</a> Infections in the puerperium

<b>TUC is:</b>	<b>when reported as the cause of:</b>	<b>code to:</b>
<a href="#">JA8A.2</a> Morbidly adherent placenta	<a href="#">JA8B.1</a> Placenta praevia with haemorrhage	<a href="#">JA8B.1</a> Placenta praevia with haemorrhage
	<a href="#">JA8B.0</a> Placenta praevia specified as without haemorrhage	<a href="#">JA8B.0</a> Placenta praevia specified as without haemorrhage
	<a href="#">JA8B.Z</a> Maternal care related to placenta praevia or low lying placenta, unspecified	<a href="#">JA8B.Z</a> Maternal care related to placenta praevia or low lying placenta, unspecified

<b>TUC is:</b>	<b>when reported as the cause of:</b>	<b>code to:</b>
<a href="#">JA8E</a> Maternal care related to prolonged pregnancy	<a href="#">JB0D</a> Certain specified complications of labour or delivery, not elsewhere classified	<a href="#">JB0D</a> Certain specified complications of labour or delivery, not elsewhere classified

<b>TUC is:</b>	<b>when reported as the cause of:</b>	<b>code to:</b>
<a href="#">JB00</a> Preterm labour or delivery	<a href="#">JA8C</a> Maternal care related to premature separation of placenta	<a href="#">JA8C</a> Maternal care related to premature separation of placenta
<a href="#">JB01</a> Failed induction of labour	<a href="#">JA42</a> Intrapartum haemorrhage	<a href="#">JA42</a> Intrapartum haemorrhage
<a href="#">JB02</a> Abnormalities of forces of labour	<a href="#">JA43</a> Postpartum haemorrhage	<a href="#">JA43</a> Postpartum haemorrhage
<a href="#">JB03</a> Long labour	<a href="#">JB04</a> - <a href="#">JB06</a> Obstructed labour due to malposition or malpresentation of foetus, maternal pelvic abnormality, or other causes	<a href="#">JB04</a> - <a href="#">JB06</a> Obstructed labour due to malposition or malpresentation of foetus, maternal pelvic abnormality, or other causes
<a href="#">JB07</a> Labour or delivery complicated by foetal distress	<a href="#">JB0D</a> Certain specified complications of labour or delivery, not elsewhere classified	<a href="#">JB0D</a> Certain specified complications of labour or delivery, not elsewhere classified
<a href="#">JB08</a> Labour or delivery complicated by umbilical cord complications	<a href="#">JB40</a> Infections in the puerperium	<a href="#">JB40</a> Infections in the puerperium

<b>TUC is:</b>	<b>when reported as the cause of:</b>	<b>code to:</b>
<a href="#">JB09.2</a> , <a href="#">JB09.3</a> , <a href="#">JB09.Z</a> Third, fourth or unspecified degree perineal laceration during delivery	<a href="#">JA43</a> Postpartum haemorrhage	<a href="#">JA43</a> Postpartum haemorrhage
	<a href="#">JB40</a> Infections in the puerperium	<a href="#">JB40</a> Infections in the puerperium

<b>TUC is:</b>	<b>when reported as the cause of:</b>	<b>code to:</b>
<a href="#">JB0C.5</a> Spinal and epidural anaesthesia-induced headache during labour and delivery	<a href="#">JB0C.3</a> Central nervous system complications of anaesthesia during labour or delivery	<a href="#">JB0C.3</a> Central nervous system complications of anaesthesia during labour or delivery

<b>TUC is:</b>	<b>when reported as the cause of:</b>	<b>code to:</b>
<a href="#">JB0D.0</a> Maternal distress during labour and delivery	<a href="#">JA43</a> Postpartum haemorrhage	<a href="#">JA43</a> Postpartum haemorrhage
<a href="#">JB0D.1</a> Shock during or following labour and delivery	<a href="#">JB40</a> Infections in the puerperium	<a href="#">JB40</a> Infections in the puerperium

<b>TUC is:</b>	<b>when reported as the cause of:</b>	<b>code to:</b>
<a href="#">JB0D.2</a> Pyrexia during labour, not elsewhere classified	<a href="#">JB40</a> Infections in the puerperium	<a href="#">JB40</a> Infections in the puerperium

<b>TUC is:</b>	<b>when reported as the cause of:</b>	<b>code to:</b>
<a href="#">JB0D.4</a> Delayed delivery after artificial rupture of membranes	<a href="#">JA43</a> Postpartum haemorrhage	<a href="#">JA43</a> Postpartum haemorrhage
<a href="#">JB0D.5</a> Delayed delivery after spontaneous or unspecified rupture of membranes	<a href="#">JB0D</a> Certain specified complications of labour or delivery, not elsewhere classified	<a href="#">JB0D</a> Certain specified complications of labour or delivery, not elsewhere classified
	<a href="#">JB40</a> Infections in the puerperium	<a href="#">JB40</a> Infections in the puerperium

<b>TUC is:</b>	<b>when reported as the cause of:</b>	<b>code to:</b>
<a href="#">JB0D.6</a> Vaginal delivery following previous caesarean section	<a href="#">JA8A.2</a> Morbidly adherent placenta	<a href="#">JA8A.2</a> Morbidly adherent placenta
	<a href="#">JB0A.1</a> Rupture of uterus during labour	<a href="#">JB0A.1</a> Rupture of uterus during labour
	<a href="#">JB0A.2</a> Postpartum inversion of uterus	<a href="#">JB0A.2</a> Postpartum inversion of uterus
	<a href="#">JA43</a> Postpartum haemorrhage	<a href="#">JA43</a> Postpartum haemorrhage
	<a href="#">JB0D</a> Certain specified complications of labour or delivery, not elsewhere classified	<a href="#">JB0D</a> Certain specified complications of labour or delivery, not elsewhere classified
	<a href="#">JB40</a> Infections in the puerperium	<a href="#">JB40</a> Infections in the puerperium

<b>TUC is:</b>	<b>when reported as the cause of:</b>	<b>code to:</b>
<a href="#">JB41.0</a> Superficial thrombophlebitis in the puerperium	<a href="#">JB42.2</a> Obstetric blood-clot embolism	<a href="#">JB42.2</a> Obstetric blood-clot embolism
<a href="#">JB41.2</a> Haemorrhoids in the puerperium		
<a href="#">JB41.Y</a> Other venous complications in the puerperium		
<a href="#">JB41.Z</a> Venous complication in the puerperium, unspecified		

<b>TUC is:</b>	<b>when reported as the cause of:</b>	<b>code to:</b>
<a href="#">JB43.3</a> Spinal and epidural anaesthesia-induced headache during the puerperium	<a href="#">JB43.2</a> Central nervous system complications of anaesthesia during the puerperium	<a href="#">JB43.2</a> Central nervous system complications of anaesthesia during the puerperium

### 2.19.3.19 Special instructions on Chapter 19 Certain conditions originating in the perinatal period

### 2.19.3.20 Special instructions on Chapter 20 Developmental anomalies

<b>TUC is:</b>	<b>with mention of:</b>	<b>code to:</b>
<a href="#">LB20.00</a> Fibropolycystic liver disease	<a href="#">GB81</a> Autosomal dominant polycystic kidney disease	<a href="#">GB81</a> Autosomal dominant polycystic kidney disease
	<a href="#">GB8Y</a> Other specified cystic or dysplastic kidney disease	<a href="#">GB8Y</a> Other specified cystic or dysplastic kidney disease

### 2.19.3.21 Special instructions on Chapter 21 Symptoms, signs or clinical findings, not elsewhere classified

<b>TUC is:</b>	<b>when reported as the cause of:</b>	<b>code to:</b>
<a href="#">MA14.0</a> Laboratory evidence of human immunodeficiency virus	[[01](https://icd.who.int/browse/latest-release/mms/en#1435254666)] Chapter 01 Certain infectious or parasitic diseases	<a href="#">1C60-1C62.Z</a> Human immunodeficiency virus disease

### 2.19.3.22 Special instructions on Chapter 22 Injury, poisoning or certain other consequences of external causes

### 2.19.3.23 Special instructions on Chapter 23 External causes of morbidity or mortality

<b>TUC is:</b>	<b>with mention of:</b>	<b>code to:</b>
<a href="#">PA00-PB6Z</a> Unintentional causes	<a href="#">1C13</a> Tetanus	<a href="#">1C13</a> Tetanus

### 2.19.3.24 Codes not to be used for underlying cause of death

Categories specified in the left-hand column of this section should not be used as the underlying cause of death. Select the category in the right-hand column as appropriate.

<b>TUC is:</b>	<b>code to:</b>
<a href="#">1D9Y</a> & <a href="#">XN275</a> Respiratory syncytial virus infection	<a href="#">CA40.11</a> Pneumonia due to Respiratory syncytial virus (RSV)

**TUC is:**

[2D50-2E2Z](#) Malignant neoplasm metastases

**code to:**

[2D40-2D4Z](#) Malignant neoplasms of ill- or unspecified primary sites, if the primary site of malignant neoplasm is not known or not indicated

**TUC is:**

[5A20.0](#) - [5A2Y](#) Acute complications of diabetes mellitus

**code to:**

[5A10-5A13](#) if type of diabetes is stated **or code to** [5A14](#) Diabetes mellitus, type unspecified, if the type of diabetes is not stated

[8B92.2](#) Diabetic lumbosacral plexopathy

[8B94](#) Diabetic radiculoplexoneuropathy

[8C03.0](#) Diabetic polyneuropathy

[8D88.1](#) Autonomic neuropathy due to diabetes mellitus

[9B10.21](#) Diabetic cataract

[9B71.00](#) - [9B71.0Z](#) Diabetic retinopathy

[BC43.7](#) Diabetic cardiomyopathy

[BD54](#) Diabetic foot ulcer

[EB90.0](#) Diabetic skin lesions

[FA38.0](#) Diabetic arthropathy

[FA38.10](#) Diabetic Charcot arthropathy

[MF83](#) Diabetic glomerular changes

**TUC is:**

[5D40-5D46](#) Postprocedural endocrine or metabolic disorders

See Section [2.18.4 Step M4 - Instructions on medical procedures, main injury, poisoning, and maternal deaths](#)

[8E60-8E66](#) Postprocedural disorders of the nervous system

[9D20-9D25](#) Postprocedural disorders of eye or ocular adnexa

[AB90-AB93](#) Postprocedural disorders of ear or mastoid process

[BE10-BE1F.1](#) Postprocedural disorders of circulatory system

[CB60-CB64](#) Postprocedural disorders of the respiratory system

[DE10-DE13](#) Postprocedural disorders of digestive system

[FC01](#) Postprocedural disorders of the musculoskeletal system

[GC70-GC7C](#) Postprocedural disorders of genitourinary system

**TUC is:**

[6C40.3](#) Alcohol intoxication

**code to:**

[PB30](#) Unintentional exposure to or harmful effects of alcohols if Manner of death stated on MCCD is disease

[PB30](#) Unintentional exposure to or harmful effects of alcohols if Manner of death stated on MCCD is accident

[PD00](#) Intentional self-harm by exposure to or harmful effects of alcohols if Manner of death stated on MCCD is intentional self-harm

[PE90](#) Assault by exposure to or harmful effects of alcohols if Manner of death stated on MCCD is assault

[PH50](#) Exposure to or harmful effects of undetermined intent of alcohols if Manner of death stated on MCCD could not be determined

[PB30](#) Unintentional exposure to or harmful effects of alcohols if Manner of death stated on MCCD is pending investigation

[PB30](#) Unintentional exposure to or harmful effects of alcohols if Manner of death stated on MCCD is unknown



**TUC is:**

[6C43.3](#) Opioid  
intoxication

**code to:**

[PB20](#) Unintentional exposure to or harmful effects of opioids or  
related analgesics if Manner of death stated on MCCD is disease

[PB20](#) Unintentional exposure to or harmful effects of opioids or  
related analgesics if Manner of death stated on MCCD is accident

[PC90](#) Intentional self-harm by exposure to or harmful effects of  
opioids or related analgesics if Manner of death stated on MCCD is  
intentional self-harm

[PE80](#) Assault by exposure to or harmful effects of opioids or related  
analgesics if Manner of death stated on MCCD is assault

[PH40](#) Exposure to or harmful effects of undetermined intent of  
opioids or related analgesics if Manner of death stated on MCCD  
could not be determined

[PB20](#) Unintentional exposure to or harmful effects of opioids or  
related analgesics if Manner of death stated on MCCD is pending  
investigation

[PB20](#) Unintentional exposure to or harmful effects of opioids or  
related analgesics if Manner of death stated on MCCD is unknown

**TUC is:**

[6C41.3](#) Cannabis intoxication [6C42.3](#)  
Synthetic cannabinoid intoxication  
[6C49.3](#) Hallucinogen intoxication

**code to:**

[PB23](#) Unintentional exposure to or harmful effects  
of cannabinoids or hallucinogens if Manner of  
death stated on MCCD is disease

[PB23](#) Unintentional exposure to or harmful effects  
of cannabinoids or hallucinogens if Manner of  
death stated on MCCD is accident

[PC93](#) Intentional self-harm by exposure to or  
harmful effects of cannabinoids or hallucinogens if  
Manner of death stated on MCCD is intentional  
self-harm

[PE83](#) Assault by exposure to or harmful effects of  
cannabinoids or hallucinogens if Manner of death  
stated on MCCD is assault

[PH43](#) Exposure to or harmful effects of  
undetermined intent of cannabinoids or  
hallucinogens if Manner of death stated on MCCD  
could not be determined

[PB23](#) Unintentional exposure to or harmful effects  
of cannabinoids or hallucinogens if Manner of  
death stated on MCCD is pending investigation

[PB23](#) Unintentional exposure to or harmful effects  
of cannabinoids or hallucinogens if Manner of  
death stated on MCCD is unknown

**TUC is:**

[6C45.3](#) Cocaine intoxication [6C46.3](#) Stimulant intoxication including amphetamines, methamphetamine or methcathinone [6C47.3](#) Synthetic cathinone intoxication [6C48.2](#) Caffeine intoxication [6C4C.3](#) MDMA or related drug intoxication, including MDA

**code to:**

[PB22](#) Unintentional exposure to or harmful effects of psychostimulants if Manner of death stated on MCCD is disease

[PB22](#) Unintentional exposure to or harmful effects of psychostimulants if Manner of death stated on MCCD is accident

[PC92](#) Intentional self-harm by exposure to or harmful effects of psychostimulants if Manner of death stated on MCCD is intentional self-harm

[PE82](#) Assault by exposure to or harmful effects of psychostimulants if Manner of death stated on MCCD is assault

[PH42](#) Exposure to or harmful effects of undetermined intent of psychostimulants if Manner of death stated on MCCD could not be determined

[PB22](#) Unintentional exposure to or harmful effects of psychostimulants if Manner of death stated on MCCD is pending investigation

[PB22](#) Unintentional exposure to or harmful effects of psychostimulants if Manner of death stated on MCCD is unknown

**TUC is:**

[6C44.3](#) Sedative, hypnotic or anxiolytic intoxication [6C4B.3](#) Volatile inhalant intoxication [6C4D.3](#) Dissociative drug intoxication including Ketamine or PCP

**code to:**

[PB21](#) Unintentional exposure to or harmful effects of sedative hypnotic drugs or other CNS depressants if Manner of death stated on MCCD is disease

[PB21](#) Unintentional exposure to or harmful effects of sedative hypnotic drugs or other CNS depressants if Manner of death stated on MCCD is accident

[PC91](#) Intentional self-harm by exposure to or harmful effects of sedative hypnotic drugs or other CNS depressants if Manner of death stated on MCCD is intentional self-harm

[PE81](#) Assault by exposure to or harmful effects of sedative, hypnotic drugs or other CNS depressants if Manner of death stated on MCCD is assault

[PH41](#) Exposure to or harmful effects of undetermined intent of sedative hypnotic drugs or other CNS depressants if Manner of death stated on MCCD could not be determined

[PB21](#) Unintentional exposure to or harmful effects of sedative hypnotic drugs or other CNS depressants if Manner of death stated on MCCD is pending investigation

[PB21](#) Unintentional exposure to or harmful effects of sedative hypnotic drugs or other CNS depressants if Manner of death stated on MCCD is unknown

**TUC is:**

[6C4E.3](#) Other specified psychoactive substance intoxication [6C4G.3](#)

Intoxication due to unknown or unspecified psychoactive substance

**code to:**

[PB28](#) Unintentional exposure to or harmful effects of other or unspecified drug, medicament or biological substance if Manner of death stated on MCCD is disease

[PB28](#) Unintentional exposure to or harmful effects of other or unspecified drug, medicament or biological substance if Manner of death stated on MCCD is accident

[PC98](#) Intentional self-harm by exposure to other and unspecified drug, medicament and biological substance if Manner of death stated on MCCD is intentional self-harm

[PE88](#) Assault by exposure to or harmful effects of other or unspecified drug, medicament or biological substance if Manner of death stated on MCCD is assault

[PH48](#) Exposure to or harmful effects of undetermined intent of other or unspecified drugs, medicaments or biological substances if Manner of death stated on MCCD could not be determined

[PB28](#) Unintentional exposure to or harmful effects of other or unspecified drug, medicament or biological substance if Manner of death stated on MCCD is pending investigation

[PB28](#) Unintentional exposure to or harmful effects of other or unspecified drug, medicament or biological substance if Manner of death stated on MCCD is unknown

<b>TUC is:</b>	<b>code to:</b>
<a href="#">6D80</a> Dementia due to Alzheimer disease	<a href="#">8A20</a> , Alzheimer disease
<a href="#">6D81</a> Dementia due to cerebrovascular disease	The originating cerebrovascular disease in Chapter 08 ' <a href="#">8B00</a> to <a href="#">8B2Z</a> Cerebrovascular diseases, unspecified' and if not reported code to <a href="#">8B2Z</a> Cerebrovascular diseases, unspecified
<a href="#">6D82</a> Dementia due to Lewy body disease	<a href="#">8A22</a> , Lewy body disease
<a href="#">6D83</a> Frontotemporal dementia	<a href="#">8A23</a> , Frontotemporal lobar degeneration
<a href="#">6D84.0</a> Dementia due to use of alcohol	The originating disorder due to use of alcohol, if not reported code to <a href="#">6C40.Y</a> , other specified disorders due to use of alcohol
<a href="#">6D84.1</a> Dementia due to use of sedatives, hypnotics or anxiolytics	The originating disorder due to use of sedative, hypnotic or anxiolytic, if not reported code to <a href="#">6C44.Y</a> , other specified disorders due to use of sedative, hypnotic or anxiolytic
<a href="#">6D84.2</a> Dementia due to use of volatile inhalants	The originating disorder due to use of volatile inhalants, if not reported code to <a href="#">6C4B.Y</a> , other specified disorders due to use of volatile inhalant
<a href="#">6D84.Y</a> Dementia due to other specified psychoactive substance	The originating disorder due to other specified psychoactive substance, if not reported code to <a href="#">6C4G.Y</a> Other specified disorders due to use of unknown or unspecified psychoactive substances
<a href="#">6D85.0</a> Dementia due to Parkinson disease	<a href="#">8A00.0Z</a> , Parkinson disease, unspecified
<a href="#">6D85.1</a> Dementia due to Huntington disease	<a href="#">8A01.10</a> Huntington disease, unspecified
<a href="#">6D85.2</a> Dementia due to exposure to heavy metals and other toxins	<a href="#">PB36</a> Unintentional exposure to or harmful effects of other or unspecified substances chiefly nonmedicinal as to source <a href="#">PB80-PD3Z</a> Intentional self-harm, unspecified <a href="#">PE95</a> Assault exposure to or harmful effects of other or unspecified substances chiefly nonmedicinal as to source <a href="#">PH56</a> Exposure to or harmful effects of other or unspecified substances chiefly nonmedicinal as to source, undetermined intent
<a href="#">6D85.3</a> Dementia due to human immunodeficiency virus	<a href="#">1C62.3</a> , HIV disease clinical stage 4 without mention of tuberculosis or malaria
<a href="#">6D85.4</a> Dementia due to multiple sclerosis	<a href="#">8A40.Z</a> , multiple sclerosis, unspecified
<a href="#">6D85.5</a> Dementia due to prion disease	Prion disease mentioned, <a href="#">8E0Z</a> Human prion diseases, unspecified

**TUC is:**

[6D85.6](#) Dementia due to normal pressure hydrocephalus

[6D85.7](#) Dementia due to injury to the head

[6D85.8](#) Dementia due to pellagra

[6D85.9](#) Dementia due to Down syndrome

[6D85.Y](#) Dementia due to other specified diseases classified elsewhere

[6D8Y](#) Dementia, other specified cause

**code to:**

[8D64.04](#) Normal-pressure hydrocephalus

External cause that caused head injury, if unspecified Code to: [PB6Z](#) Unspecified unintentional cause of morbidity or mortality [PD05](#) Intentional self-harm, unspecified [PF2Z](#) Assault, unspecified [PH8Y](#) Other specified injury event of undetermined intent

[5B5C.0](#), Pellagra

[LD40.0](#), Down syndrome

specified disease

specified cause

**TUC is:**

[BA42](#) Subsequent myocardial infarction

**Code to:** [BA41](#) Acute myocardial infarction

[BA60](#) Certain current complications following acute myocardial infarction

**TUC is:**

[BA43](#) Coronary thrombosis not resulting in myocardial infarction

**Code to:** [BA41](#) Acute myocardial infarction For mortality, the occurrence of myocardial infarction is assumed.

**TUC is:**

[BA50](#) Old myocardial infarction

**Code to:** [BA5Z](#) Chronic ischaemic heart disease, unspecified, if the cause is not stated

**TUC is:**

[BD55](#) Asymptomatic stenosis of intracranial or extracranial artery

**Code to:** [8B11](#) Cerebral ischaemic stroke For mortality, the occurrence of cerebral infarction is assumed.

[BD56](#) Asymptomatic occlusion of intracranial or extracranial artery

**TUC is:**

[JA05](#) Complications following abortion, ectopic or molar pregnancy

**Code to:** [JA00-JA0Z](#) Abortive outcome of pregnancy **except** [JA05](#) Complications following abortion, ectopic or molar pregnancy

**TUC is:**

[JB65](#) Sequelae of complication of pregnancy, childbirth or the puerperium

**Code to:** [JB62](#) Death from sequelae of obstetric causes

**TUC is:**

[KB60-KB6Z](#) Transitory endocrine or metabolic disorders specific to Fetus or newborn, **except** [KB60.0](#) Syndrome of infant of mother with gestational diabetes; [KB60.1](#) Syndrome of infant of a diabetic mother, type 1 or 2, nongestational, insulin dependent; [KB60.2](#) Neonatal diabetes mellitus; or [KB62.0](#) Transitory neonatal hyperthyroidism

**Code to:** other perinatal cause. If no other perinatal cause is reported, **code to:** [KD5Z](#) Conditions originating in the perinatal or neonatal period, unspecified

**TUC is:**

[MA13.1](#) Finding of alcohol in blood

**Code to:** [MH14](#) Other ill-defined and unspecified causes of mortality

**TUC is:**

[MA15.Y](#) Other specified microbiological findings in blood, blood-forming organs, or the immune system

**Code to:** The originating infectious disease in Chapter 01 'Certain infectious or parasitic diseases', or to [1G40](#) Sepsis without septic shock - [1G41](#) Sepsis with septic shock.



**TUC is:**

[MG20.0](#) Malignant cachexia

**Code to:** [2D4Z](#) Unspecified malignant neoplasms of ill-defined or unspecified sites

**TUC is:**

[MG48](#) Unknown and unspecified causes of morbidity

**Code to:** [MH10](#) - [MH14](#) Ill-defined and unknown causes of mortality

**TUC is:**

Chapter 22 Injury, poisoning or certain other consequences of external causes

**Not to be used for the underlying cause of death, except as an additional code to the relevant category in Chapter 23** (see also Step M4).

Consider a fracture as pathological when a disease of bone density is reported next to or as the cause of the fracture, and **code to:** [FB80.B](#) Pathological fracture, not elsewhere classified

**TUC is:**

24 Factors influencing health status or contact with health services

**Not to be used during the selection of the underlying cause of death**

**Code to:** [MH14](#) Other ill-defined and unspecified causes of mortality **if nothing else is reported on the certificate**

**TUC is:**

Chapter X Extension codes, **except** infectious agents

**Code to:** [MH14](#) Other ill-defined and unspecified causes of mortality

**TUC is:**

Infectious agents in Chapter X Extension codes

**Code to:** the infection of the infectious agent of unspecified site. See also [2.21.8.11](#).

[2.23.19](#)

**2.19.3.25 Codes not to be used if the underlying cause is known or other specific conditions apply**

For the conditions specified in the left-hand column of this section, if the condition specified in the right-hand column **does not apply**, then keep the condition as the tentative underlying cause.

**TUC is:**

[2D43](#) Malignant neoplasms of independent, multiple primary sites

**Not to be used for the underlying cause of death, if the multiple neoplasms are reported separately.**

**Code to:** [2A00-2A0Z](#) Neoplasms of brain or central nervous system; [2A20-2B3Z](#) Neoplasms of haematopoietic or lymphoid tissues; or [2B50-2D3Z](#) Malignant neoplasms, stated or presumed to be primary, of specified sites, except of lymphoid, haematopoietic, central nervous system or related tissues

**TUC is:**

[6A00](#) Disorders of intellectual development [6A01](#)  
Developmental speech or language disorders [6A03](#)  
Developmental learning disorder [6E60-6E6Z](#) Secondary mental or behavioural syndromes associated with disorders or diseases classified elsewhere

**Not to be used for the underlying cause of death, if the underlying physical condition is known.**

**Code to:** the underlying physical condition.

**TUC is:**

[6C4A](#) Disorders due to use of nicotine

**Not to be used for the underlying cause of death, if the resultant physical condition is known.**

**Code to:** the resultant physical condition.

**TUC is:**

[BC00](#) Multiple valve disease

**Not to be used for underlying cause of death, if the multiple valve diseases are reported separately and nonrheumatic origin.**

**Code to:** each valve disease specified by the coding tool, and select the underlying cause by applying the selection and modification rules in the normal way.

**TUC is:**

[JA80](#) Maternal care related to multiple gestation

**Not to be used for the underlying cause of death, if a more specific complication is reported.**

**Code to:** the more specific complication.

If there is no specific complication, **code to** [JB0Z](#)  
Complications of labor or delivery, unspecified

**TUC is:**

[JB20](#) - [JB2Z](#)  
Delivery

**Not to be used for the underlying cause of death, if a more specific complication is reported.**

**Code to:** code to the more specific complication of [JB0C](#).- to [JB0D](#).- or [JB0Y](#). If no complication is reported **code to** [JB0Z](#).

**TUC is:**

[KA21](#) Disorders of newborn related to short gestation or low birth weight, not elsewhere classified  
[KA22](#) Disorders of newborn related to long gestation or high birth weight

**Not to be used for the underlying cause of death, if any other cause of perinatal mortality or any developmental anomaly is reported.** This does not apply for [KB2D](#) Respiratory failure of newborn or [KB2E](#) Respiratory Arrest of newborn, which are ill-defined conditions and should not be used for underlying cause of death.

**Code to:** the other specified cause of perinatal mortality, or developmental anomaly  
([19](https://icd.who.int/browse/latest-release/mms/en#1306203631)] Chapter 19 Certain conditions originating in the perinatal period except for [KB2D](#) Respiratory failure of newborn or [KB2E](#) Respiratory arrest of newborn

**TUC is:**

[KD3B](#) Fetal death, cause not specified

**Not to be used for the underlying cause of death of live births.**

**Code to:** [KD5Z](#) Conditions originating in the perinatal or neonatal period, unspecified, if the child was born alive but the cause death is unknown. See also: [2.21.8.4] (#special-instructions-on-fetal-death)

**TUC is:**

[KD3B](#) Fetal death, cause not specified

**Not to be used for the underlying cause of fetal death, if any other cause of fetal mortality is known.**

**Code to:** the other cause of fetal mortality.

**TUC is:**

[MB50-MB5Z](#) Paralytic symptoms

**Not to be used for the underlying cause of death, if the cause of the paralysis is known.**

**Code to:** the cause of the paralysis.

**TUC is:**

[NFOA](#) Certain early complications of trauma, not elsewhere classified

**Not to be used for the underlying cause of death, if the initial injury is known.**

**Code to:** the initial injury

## 2.19.4 Special instructions on surgery and other medical procedures (Step M4)

### 2.19.4.1 Reason for the surgery or procedure stated

If the tentative underlying cause selected by applying Steps SP1 to SP8 and M1 to M3 is surgery or other medical procedure and the certificate states the reason for which the operation or procedure was performed, then select the reason for the operation or procedure as the new tentative underlying cause of death. Next, reapply the instructions in Steps SP7 and M1 to M4.

### 2.19.4.2 Reason for the surgery or procedure not stated, complication reported

If the reason for the surgery or procedure is not stated and a complication is reported, proceed as described next.

- a) Surgery indicates specific organ: First, if the type of surgery or procedure indicates a specific organ or site, then use the code for the residual category for the organ or site operated on as the new tentative underlying cause of death. Next, reapply the instructions in Steps SP7 and M1 to M4.
- b) If above does not apply, then use the appropriate code from:
  - [JBOC](#) *Complications of anaesthesia during labour or delivery*
  - [JBOD.3](#) *Other complications of obstetric surgery or procedures or*
  - [PK80-PK8Z](#) *Surgical or other medical procedures associated with injury or harm in diagnostic or therapeutic use*
  - [PL11](#) *Mode of injury or harm associated with a surgical or other medical procedure*

When both [PK80-PK8Z](#) and [PL11](#) applies, then code the mode of injury or harm ([PL11](#)) first and add the type of surgery or procedure [PK80-PK8Z](#) to the cluster.

### 2.19.4.3 Reason for the surgery or procedure not stated, no complication reported

If the reason for the surgery or procedure is not stated and no complication is reported, proceed as described next:

- a) Surgery indicates specific organ: If the type of surgery or procedure indicates a specific organ or site, then use the code for the residual category for the organ or site operated on as the new starting point. Next, reapply the instructions in Steps SP7 and M1 to M4.
- b) Lastly, if above does not apply, code to [MH14](#) *Other ill-defined or unspecified causes of mortality*.

### Example 1

- 1 (a) Postoperative haemorrhage
  - (b) Caesarean section
  - (c)
  - (d)
- 2

Reason for surgery      Prolonged labour

The certificate states the reason why the surgery was performed. Code the reason for the surgery, prolonged labour, as the underlying cause of death [JB03.Z](#) *Long labour, unspecified*.

### Example 2

- 1 (a) Pulmonary embolism
  - (b) Appendectomy
  - (c)
  - (d)
- 2

The certificate does not specify the reason for the surgery, but a complication of the surgery pulmonary embolism is reported. The term appendectomy indicates appendix as the organ operated on. Code [DB1Z](#) *Diseases of appendix, unspecified* as the underlying cause of death.

### Example 3

- 1 (a) Unintentional puncture of aorta
  - (b) Laparotomy
  - (c)
  - (d)
- 2

The certificate does not specify the reason for the surgery and the term laparotomy does not indicate a specific organ. However, there is a mention of a mode of injury at the time of the surgery. Code the mode of injury, unintentional puncture during laparotomy as the underlying cause of death [PL11.0](#) *Cut, puncture or tear, as mode of injury or harm*.

### Example 4

- 1 (a) Laparotomy
  - (b)
  - (c)
  - (d)
- 2

The certificate does not specify why the surgery was performed and the term laparotomy does not indicate a specific organ. There is no mention of a complication. Code [MH14](#) *Other ill-defined or unspecified causes of mortality*, as the underlying cause of death.

#### 2.19.4.4 Medical devices associated with adverse incidents due to external causes

If a death is caused by an incident involving a medical device, but the incident is due to an external cause and not to any breakdown or malfunctioning of the device itself, code the external cause as the underlying cause of death.

If the external cause of the incident is not specifically classified, code to [PB6Z](#) *Unspecified unintentional cause of morbidity or mortality* (See example 3).

##### Example 1

- 1 (a) Inhalation pneumonia
- (b) Haemorrhage of trachea
- (c) Fell from bed while attached to respirator
- (d)
- 2 Respiratory treatment following liver transplant

There is no mention of breakdown or malfunctioning of the respirator or the tracheal tube. Code [PL14.E](#) *Fall in health care*, the accident that caused the haemorrhage, as the underlying cause of death, and additional code, if desired, for [XE8PK](#) *Bed, bedding or bedding accessories*.

##### Example 2

- 1 (a) Pulmonary oedema
- (b) Intra-aortic balloon pump stopped
- (c) Power cut due to hurricane
- (d) Recent myocardial infarction with mitral insufficiency
- 2

The balloon pump stopped working, not because of any malfunctioning or breakdown, but because of a power cut. Code the reason of the power cut, cataclysmic storm, as the underlying cause of death, ([PJ06](#)).

##### Example 3

- 1 (a) Cardiac and respiratory failure
- (b) Stopped administration of inotropic drugs
- (c) Accidental removal of subclavian line
- (d)
- 2 Surgery for acute rupture of gallbladder

There is no mention of malfunctioning or breakdown of equipment. Since the accident that caused the removal of the subclavian line is not described, code to [PB6Z](#) *Unspecified unintentional cause of morbidity or mortality*.

#### 2.19.5 Special instructions on main injury in deaths from external causes (Step M4)

If the underlying cause selected by applying the selection and modification rules in Steps SP1 to SP8 and M1 to M3 is an injury, code the external cause of the injury as the underlying cause of death.

In addition to the underlying cause from Chapter 23 'External causes of morbidity and mortality', also code a main injury. This applies to both body injuries and poisoning. For special instructions on how to identify the underlying cause and main injury in poisoning

deaths, see Section [2.19.6 Special instructions on poisoning by drugs, medications and biological substances \(Step M4\)](#).

If more than one injury is reported on the death certificate, apply the following instructions:

- (a) When the injuries reported include trivial injuries (those listed in Annex [3.14.10 List of conditions unlikely to cause death](#)), whether in Part 1 or Part 2, select the main injury as if the injuries in the list of Annex [3.14.10](#) had not been reported.

Example 1

- 1 (a) Contusion of arm and fracture of skull  
(b) Fall from scaffolding  
(c)  
(d)
- 2

Fall from scaffolding is the underlying cause of death. Code underlying cause to [PA61 Unintentional fall from a height of 1 metre or more](#) and use additional code, if desired, for the [XE7RK Scaffolding](#). As main injury, code [NA02.Z Fracture of skull or facial bones, part unspecified](#). Disregard contusion of arm (Superficial injury of upper limb, level unspecified), as it is in the Annex [3.14.10 List of conditions unlikely to cause death](#).

- (b) When non-trivial injuries are reported in both Part 1 and Part 2, select the main injury from Part 1. This applies even when the injuries mentioned in Part 2 have a higher rank in Annex [3.14.5 Priority ranking of Nature-of-Injury codes](#), than the injuries mentioned in Part 1.

Example 2

- 1 (a) Multiple intrathoracic injuries  
(b) Car driver, collision with bus  
(c)  
(d)
- 2 Brain injuries

Code to [PA04 Unintentional land transport traffic event injuring a car occupant](#), and use additional code, if desired, for [XE5LJ Bus or coach as counterpart in land transport crash](#). As main injury, code [NB32.7 Multiple injuries of intrathoracic organs](#). Unspecified brain injury has a higher rank in Annex [3.14.5 Priority ranking of Nature-of-Injury codes](#) than multiple injuries of thorax, but multiple injuries of thorax are mentioned in Part 1 and take precedence over the injuries mentioned in Part 2.

- (c) When non-trivial injuries are reported only in Part 2, select a main injury from Part 2.
- (d) When more than one serious injury is reported in the relevant part of the certificate, select the main injury according to Annex [3.14.5 Priority ranking of Nature-of-Injury codes](#). Note that 1 is the highest priority rank and that 6 the lowest.

### Example 3

- 1 (a) Multiple intrathoracic injuries and brain injuries
- (b) Car driver, collision with bus
- (c)
- (d)

2

Code to [PA04 Unintentional land transport traffic event injuring a car occupant](#) as underlying cause of death. As main injury, code brain injury [NA07.Z Intracranial injury, unspecified](#), which has a higher rank on the priority list than [NB32.7 Multiple injuries of intrathoracic organs](#).

- (e) When more than one of the serious injuries reported in the relevant part of the certificate have the same and highest rank, select the first mentioned of these injuries. However, select a specific injury over an injury from the group [ND30-ND37 Injuries involving multiple body regions](#) with the same priority rank.

### Example 4

- 1 (a) Multiple injuries with traumatic subdural haemorrhage
- (b) Car driver, collision with bus
- (c)
- (d)

2

Code to [PA04 Unintentional land transport traffic event injuring a car occupant](#) as underlying cause of death. As main injury, code [NA07.6Z Traumatic subdural haemorrhage, unspecified whether acute or chronic](#). Multiple injuries and traumatic subdural haemorrhage have the same rank on the priority list, but a specific injury takes precedence over injury from the group Injuries involving multiple body regions.

## 2.19.6 Special instructions on poisoning by drugs, medications and biological substances (Step M4)

If poisoning is the tentative underlying cause in Step M4 and multiple substances are reported, follow the instructions in this section.

### 2.19.6.1 The drug most likely to have caused death is specified

If one of the substances is specified as the substance most likely to have caused the death, code the external cause code for that substance as the underlying cause of death. Use additional code from Chapter X, if applicable, to identify the specific substance reported, and add the main injury from Chapter 22 to the cluster.

### Example 1

- 1 (a) Unintentional heroin overdose
  - (b)
  - (c)
  - (d)
- 2 Diazepam and amitriptyline present

By placing heroin overdose alone in Part 1 and reporting the other substances as contributing causes of death in Part 2, the certifier has identified heroin as the substance most likely to have caused the death.



Select [PB20](#) *Unintentional exposure to or harmful effects of opioids or related analgesics* as underlying cause. Use additional code [XM05B3](#) *Diamorphine* to identify the specific substance reported. Add main injury from Chapter 22 [NE60](#) *Harmful effects of drugs, medicaments or biological substances, not elsewhere classified*, NEC to the cluster. The cluster is [PB20&XM05B3/NE60](#).

#### Example 2

- 1 (a) Poisoning by amphetamine  
(b)  
(c)  
(d)
- 2 Toxic levels of heroin and flunitrazepam

By placing amphetamine poisoning alone in Part 1 and reporting the other substances as contributing causes of death in Part 2, the certifier has identified amphetamine as the substance most likely to have caused the death. Select [PB22](#) *Unintentional exposure to or harmful effects of psychostimulants* as underlying cause. Use additional code [XM48Z9](#) *Amphetamine* to identify the specific substance reported. And add [NE60](#) *Harmful effects of drugs, medicaments or biological substances, not elsewhere classified* to the cluster. The cluster is [PB22&XM48Z9/NE60](#).

#### Example 3

- 1 (a) Poisoning by alcohol  
(b)  
(c)  
(d)
- 2 Toxic levels of heroin and flunitrazepam

By placing alcohol poisoning alone in Part 1 and reporting the other substances as contributing causes of death in Part 2, the certifier has identified alcohol as the substance most likely to have caused the death. Select [PB30](#) *Unintentional exposure to or harmful effects of alcohols* as underlying cause. And add [NE61](#) *Harmful effects of or exposure to noxious substances, chiefly nonmedicinal as to source, not elsewhere classified* to the cluster. The cluster is [PB30/NE61](#).

#### Example 4

- 1 (a) Alcohol poisoning  
(b)  
(c)  
(d)
- 2 Diazepam and amitriptyline present

By placing alcohol poisoning alone in Part 1 and reporting the other substances as contributing causes of death in Part 2, the certifier has identified alcohol as the most important substance in bringing about the death. Select [PB30](#) *Unintentional exposure to or harmful effects of alcohols* as underlying cause. And add [NE61](#) *Harmful effects of or exposure to noxious substances, chiefly nonmedicinal as to source, not elsewhere classified* to the cluster. The cluster is [PB30/NE61](#).

### 2.19.6.2 The drug most likely to have caused death is not specified

If multiple substances are reported as contributing to the death but none of the substance is specified as the substance most likely to have caused the death, follow these instructions:

(a) Code combinations of alcohol with a drug to the drug

Example 5

- 1 (a) Toxic levels of alcohol and flunitrazepam
  - (b)
  - (c)
  - (d)
- 2 Diazepam and amitriptyline present

By placing toxic levels of alcohol and flunitrazepam in Part 1 and reporting the other substances as contributing causes of death in Part 2, the certifier has identified alcohol and flunitrazepam as the most important substances in bringing about the death. Of these two, select poisoning by flunitrazepam because combinations of alcohol with a drug are coded to the drug. Select [PB21](#) *Unintentional exposure to or harmful effects of sedative hypnotic drugs or other CNS depressants* as underlying cause. Use additional code [XM9W71](#) *Flunitrazepam* to identify the specific substance reported. And add [NE60](#) *Harmful effects of drugs, medicaments or biological substances, not elsewhere classified, NEC*. The cluster is [PB21&XM9W71/NE60](#).

(b) Code combinations of multiple drugs, as follows:

- If the external cause of the multiple drugs reported is the same select that as the underlying cause of death.
- If the external cause of the multiple drugs reported is not the same, code [PB29](#) *Unintentional exposure to or harmful effects of multiple drugs, medicaments or biological substances* as the underlying cause of death.

Use additional code from Chapter X, if applicable, to identify the substance most likely to have caused the death by referring to Section [2.19.6.3 Identification of the drug most likely to have caused death](#).

Note that when adding more than one drugs in optional use cases, the substance most likely to have caused the death identified as above must be coded first.

Example 6

- 1 (a) Toxic levels of heroin and amphetamine
  - (b)
  - (c)
  - (d)
- 2

Neither heroin nor amphetamine are identified as the substance most likely to have caused the death and the external cause of these drugs are not the same. Code to [PB29](#) *Unintentional exposure to or harmful effects of multiple drugs, medicaments or biological substances* as the underlying cause of death. Go to Section [2.19.6.3](#) to identify the drug most likely to have caused the death.

### Example 7

- 1 (a) Unintentional poisoning by alcohol, heroin, and diazepam
- (b)
- (c)
- (d)

2

None of the substances is identified as the substance most likely to have caused the death. Poisoning by combinations of alcohol and drugs are coded to the drugs. Because none of the drugs is identified as most important, and the external cause code is different, code to [PB29 Unintentional exposure to or harmful effects of multiple drugs, medicaments or biological substances](#) as the underlying cause of death. And go to Section [2.19.6.3](#) to identify the substance most likely to have caused the death.

### 2.19.6.3 Identification of the drug most likely to have caused death

Use the priority order below to identify the substance most likely to have caused the death (1 = highest priority):

1. Opioid agonists and partial agonists and other and unspecified narcotics. Deaths that include multiple opioids classifiable should be prioritised as:
  - 1a. Heroin
  - 1b. Methadone
  - 1c. Opium
  - 1d. Other opioids
  - 1e. Other synthetic narcotics
  - 1f. Other and unspecified narcotics
2. Inhaled and intravenous anaesthetic agents, Includes: Propofol
3. Tricyclic and tetracyclic antidepressants
4. Barbiturates
5. 4-Aminophenolderivatives Includes: APAP, acetaminophen, paracetamol
6. Antipsychotics and neuroleptics Includes: Phenothiazine antipsychotics and neuroleptics, Butyrophenone and thioxanthene neuroleptics, Other and unspecified antipsychotics and neuroleptics
7. Antiepileptic drugs, antiparkinsonism drugs and unspecified sedatives
8. Cocaine
9. Psychostimulants with abuse potential Includes: Amphetamines and derivatives
10. Monoamine oxidase inhibitor (MAO) antidepressants and other and unspecified antidepressants. Includes: Selective serotonin reuptake inhibitors (SSRIs), venlafaxine
11. Benzodiazepines
12. Drugs and substances not listed above

If there is more than one drug in the same priority group, code to the first mentioned.

### Example 8

- 1 (a) Toxic levels of cocaine, heroin, diazepam, and amitriptyline
  - (b)
  - (c)
  - (d)
- 2

None of the drugs is identified as the substance most likely to have caused the death, and the external cause code is not the same for these substances. Code to [PB29](#) *Unintentional exposure to or harmful effects of multiple drugs, medicaments or biological substances* as the underlying cause of death. On the priority list above, cocaine is in group 8, heroin is in group 1a, diazepam is in group 11 and amitriptyline is in group 3. Use additional code [XM05B3](#) *Diamorphine* for the drug identified ([PB29](#) *Unintentional exposure to or harmful effects of multiple drugs, medicaments or biological substances* & [XM05B3](#)). Add codes, if desired, from Chapter X to list other drugs reported. Finally, add [NE60](#) *Harmful effects of drugs, medicaments or biological substances, not elsewhere classified*, to the cluster ([PB29](#) & [XM05B3](#) / [NE60](#)).

### Example 9

- 1 (a) Heroin, cocaine, diazepam and amitriptyline overdose
  - (b)
  - (c)
  - (d)
- 2

None of the drugs is identified as the substance most likely to have caused the death, and the external cause code is not the same for these substances. Code to [PB29](#) *Unintentional exposure to or harmful effects of multiple drugs, medicaments or biological substances* as the underlying cause of death. On the priority list above, heroin is in group 1a, cocaine is in group 8, diazepam is in group 11 and amitriptyline is in group 3. Use additional code [XM05B3](#) *Diamorphine* for the drug identified. Add codes, if desired, from Chapter X to list other drugs reported. Finally, add [NE60](#) *Harmful effects of drugs, medicaments or biological substances, not elsewhere classified* to the cluster. ([PB29](#) & [XM05B3](#) / [NE60](#))

### Example 10

- 1 (a) Unintentional poisoning by alcohol, heroin and diazepam
  - (b)
  - (c)
  - (d)
- 2

Poisoning by combinations of alcohol and drug(s) is coded to the drug(s), see instruction in Section [2.19.6.2](#), above. None of the drugs reported in Part 1 is identified as the substance most likely to have caused the death, and the external cause code is not the same for these substances. Code to [PB29](#) *Unintentional exposure to or harmful effects of multiple drugs, medicaments or biological substances* as the underlying cause of death. On the priority list above, heroin is in group 1a and diazepam is in group 11. Use additional code [XM05B3](#) *Diamorphine* identified as most likely to have caused death. Add code [XM8P99](#) *Diazepam*, if desired. Finally, add [NE60](#) *Harmful effects of drugs, medicaments or biological substances, not elsewhere classified* to the cluster. ([PB29](#) & [XM05B3](#) & [XM8P99](#) / [NE60](#)).

### 2.19.7 Special instructions on maternal mortality (Step M4)

For coding of maternal mortality, follow general coding instructions.

After assigning a code for each condition reported (See Coding instructions for maternal mortality in Section [2.21.8.2](#) apply the selection and modification instructions in the normal way starting from SP1 as same as other causes of death.

Then, apply Steps SP1 to SP8 and M1 to M3 and M4 for Surgery, Injury, External causes, and Poisoning, then Step M4 for maternal mortality.

Apply the following instructions against the tentative underlying cause of death (TUC). Terms used here in the instruction is as follows:

- Certain maternal diseases: [JA00.-](#) to [JB4Z](#), [JB60](#), [JB6Y](#), [1C14](#)
- Maternal diseases classified elsewhere: [JB63.-](#) (infections), [JB64.-](#) (other)
- Injury or external causes: Chapter 22, Chapter 23
- Other conditions: other than above

#### *Maternal diseases*

- If the tentative underlying cause (TUC) is ‘certain maternal diseases’ and the deceased was pregnant at the time of death, within 42 days, or the duration is unknown or unstated, keep the TUC.
- If the TUC is ‘maternal diseases classified elsewhere’ keep the TUC and postcoordinate the code for the specific disease classified elsewhere from Chapter 01-19.
- If the TUC is [JB61.0](#), [JB61.Z](#), [JB62.0](#) or [JB62.Z](#) keep it and its post-coordinated code, if any, as the TUC.
- If the TUC is ‘certain maternal diseases’ or maternal diseases classified elsewhere’ but the death occurred after 42 days but less than one year after the obstetric event, then code to [JB61.-](#) as the TUC and add the code for the specific maternal disease to the cluster.

#### *Other conditions or indirect obstetric causes*

- If the TUC is [JB61.1](#) or [JB62.1](#), keep it and its post-coordinated code if any as the TUC.
- If the TUC is ‘other conditions’, and the pregnancy contributed to death, and the deceased was pregnant at the time of death, within 42 days, or the duration is unknown or unstated, code to [JB63.-](#) or [JB64.-](#) as appropriate and add the specific ‘other condition’ to the cluster.
- If the TUC is ‘other conditions’, and the pregnancy did not contribute to death, but the deceased was pregnant at the time of death, within 42 days, keep the TUC and add [XT0S](#) Pregnancy to the cluster.
- If the TUC is ‘other conditions’, and the pregnancy did not contribute to death, and the death occurred after 42 days or more, or the duration is unknown or unstated, keep the TUC.

See ‘Determining whether pregnancy contributed to death’ in section [2.21.8.2](#) to decide whether pregnancy contributed to death from the information on the death certificate.

#### *Injury or external causes*

- If the TUC is ‘injury or external cause’, and the deceased was pregnant at the time of death, within 42 days, keep the TUC and add [XTOS](#) Pregnancy to the cluster.
- If the TUC is ‘injury or external cause’, and the death occurred after 42 days or more, or the duration is unknown or unstated, keep the TUC.

## 2.20 Coding instructions for mortality: multiple cause coding and other specific instructions

Multiple cause coding (see also Sections [2.21.1](#) - [2.21.8](#)) permits in-depth analysis of causes of death, for example of serious but avoidable complications of certain underlying causes, and the impact of coexisting conditions on the outcome of a disease process. Therefore, in mortality coding, both underlying cause and multiple causes should be recorded. Also, complete multiple cause coding is essential for a correct application of the ICD instructions for selection and modification of the underlying cause of death (see Sections [2.17](#) - [2.19](#)).

All possible detail should be retained in the multiple cause coding, since records containing all multiple cause conditions permit more thorough analysis than records with only a selection of the conditions reported on the death certificate. In particular:

- the position of the individual codes in the data record should reflect where on the certificate the corresponding diagnostic expressions were entered by the certifier, because some analyses may focus on the terminal cause of death, or on conditions reported in Part 2
- codes for common conditions, or for conditions regarded as symptomatic or less informative, should not be deleted or left out, since they may be of special interest in analysis of avoidable complications and may serve as markers of the seriousness of other conditions reported on the death certificate;
- multiple cause data should be stored in two formats:
  1. one format that shows as clearly as possible which term the certifier used on the certificate and where on the certificate each term was reported
  2. one format that takes the stated or implied relationships between the reported conditions into consideration, and where the codes have been harmonised according to the instructions in the ICD volumes.

Note that the syntax of a code string to retain ICD codes provided in a death certificate should be distinguishable from the syntax used for cluster coding in ICD (i.e. forward slash (/), ampersand (&)), while the specific syntax may differ according to different settings. Such code string could be for example, [BD10](#)|BA5Z\*5A11/9B71.OZ, where a vertical bar (|) expresses the separator between lines in Part 1, and an asterisk expresses the separator between Part 1 and Part 2, and the forward-slash (/) shows the cluster as a separator between stems following the convention of ICD.

## 2.21 Mortality Rules – Knowledgebase

The Mortality Knowledge Database will be a collection of rules that are used for determining the Underlying Cause of Death from death certificates. These rules will be based upon the Mortality coding guidelines of the ICD. The rules will cover permitted sequences, such as disease ‘a’ due to disease ‘b’, and cases where the selected cause may be modified to provide more relevant information for public health. Short summaries will describe the

scope of a rule, and decision tables will specify explicitly and independent of language the use of the rule with the codes of the mortality tabular list. 'Code sets' of the decision tables will group ICD codes that often occur together in the knowledge base or are handled similarly by the selection and modification rules; for example, as causes or consequences of diseases with some common characteristic. The information on the rules will be maintained in a database, so that the data in the rules code table can be easily validated against changes in the classification, and vice versa.

The decision tables can be used for manual coding and selection of the underlying cause of death, or for programming of software that assists in this task. In the past such Rule bases have been developed by users of ICD-10 mortality coding in an international approach, relying on decision for changes to the tables by an international group accredited by WHO.

### 2.21.1 Uncertain diagnosis

Ignore expressions indicating doubt as to the certainty of the diagnosis, for example 'apparently', 'presumably', 'probably' or 'possibly'. A tentative diagnosis, although uncertain, is of better use to mortality statistics than no diagnosis at all.

#### 2.21.1.1 Either ... or

The certifier might report alternative diagnoses, 'either diagnosis A or diagnosis B'. In such cases, proceed as follows.

#### 2.21.1.2 One condition, either one site or another

- (a) If the sites are in the same anatomical system, code to the residual category for the group or anatomical system in which the reported sites are classified.

Example 1

- 1 (a) Cancer of kidney or bladder
  - (b)
  - (c)
  - (d)
- 2

Code as [2C9Z](#) *Malignant neoplasms of urinary tract, unspecified*.

- (b) If the reported sites are in different anatomical systems, or if there is no residual category for the group or anatomical system, code to the residual category for the disease or condition specified.

Example 2

- 1 (a) Cancer of adrenal gland or kidney
  - (b)
  - (c)
  - (d)
- 2

Code as [2D42](#) *Malignant neoplasms of ill-defined sites*, since adrenal gland and kidney are in different anatomical systems.

### 2.21.1.3 One site or system, either one condition or another condition

- (a) If the reported conditions are classifiable to different subcategories, and ICD provides a group or category for the disease in general, code to the residual category of this group/category.

#### Example

1

- 1 (a) Sigmoid volvulus [DB30.1](#) or adhesions of large intestine with obstruction [DB30.2](#) [DB30](#)
- (b)
- (c)
- (d)

2

Since both sigmoid volvulus ([DB30.1](#)) and adhesion of large intestine with obstruction ([DB30.2](#)) are in the same group, code to the residual category [DB30.Z](#) *Obstruction of large intestine, unspecified*

#### Example

2

- 1 (a) Dissection of cerebral arteries [8B22.0](#) or cerebral infarction [8B11.5Z](#) [8B00-8B2Z](#)
- (b)
- (c)
- (d)

2

Since dissection of the cerebral arteries ([8B22.0](#)) and cerebral infarction ([8B11.5Z](#)) are in the same group, code to the residual category [8B2Z](#) *Cerebrovascular diseases, unspecified*.

- (b) If there is no group or category for the disease in general, code to the residual category of the disease of the anatomical site/system common to the reported conditions.

#### Example 3

- 1 (a) Tuberculosis or cancer of lung
- (b)
- (c)
- (d)

2

Code as [CB40.Y](#) *Other specified diseases of the respiratory system*. Both conditions involve the lung.



#### Example 4

- 1 (a) Stroke or heart attack
  - (b)
  - (c)
  - (d)
- 2

Code as [BE2Z](#) *Diseases of the circulatory system, unspecified*. Although stroke is classified to the nervous system chapter, both conditions are diseases of the circulatory system.

#### 2.21.1.4 Either one condition or another, different anatomical systems

When different diseases of different anatomical systems are reported as 'either ... or', code to [MG6Y](#) *Other specified clinical findings in specimens from other specified organs, systems and tissues*.

#### Example 1

- 1 (a) Gallbladder colic or coronary thrombosis
  - (b)
  - (c)
  - (d)
- 2

Code as [MG6Y](#) *Other specified clinical findings in specimens from other specified organs, systems and tissues*.

#### 2.21.1.5 Either disease or injury

When death is reported as due to either a disease or an injury, code to [MH14](#) *Other ill-defined or unspecified causes of mortality*.

#### Example 1

- 1 (a) Coronary occlusion or war injuries
  - (b)
  - (c)
  - (d)
- 2

Code as [MH14](#) *Other ill-defined or unspecified causes of mortality*.

#### 2.21.2 Effect of connecting terms

When the certifier uses a connecting term, the codes assigned must be arranged to reflect the certifier intention. There are two types of connecting terms: those implying a causal relationship, and those not implying a causal relationship between reported causes of death.

### 2.21.2.1 Connecting terms implying a causal relationship

A causal relationship can be expressed in two ways: 'due to' written or implied by a similar term; or 'resulting in' written or implied by a similar term. This applies to other connecting terms or signs that indicate a 'due to' relationship, such as 'caused by', 'because of', or similar.

#### *'Due to' written or implied by a similar term*

When one cause is certified with a connecting term implying it is due to another cause, enter the code for the first cause on the line where reported and the code for the other cause on the next lower line. Code any causes reported on the remaining lines in Part 1 on the next lower lines.

#### Example 1

- 1 (a) Heart failure due to ischaemic heart disease
  - (b) Diabetes
  - (c)
  - (d)
- 2

Heart failure is the first cause on line (a), so code it to line (a). It is reported as due to ischaemic heart disease, so code ischaemic heart disease to line (b). Move diabetes, which is written on line (b), to line (c).

#### Example 2

- 1 (a) Heart failure due to hepatocellular carcinoma
  - (b) Ischaemic heart disease
  - (c) Diabetes
  - (d)
- 2

Heart failure is the first cause on line 1(a), so code it to line (a). It is reported as due to hepatocellular carcinoma, so code hepatocellular carcinoma to line 1(b). Move ischaemic heart disease, which is reported on line 1(b), to line 1(c). Also move diabetes, which is reported on line 1(c), to line 1(d).

#### *'Resulting in' written or implied by a similar term*

When one cause is certified with a connecting term implying it resulted in another cause, enter the code for the cause following the connecting term on the line where reported, and the code for the cause preceding the connecting term on the next lower line. Code any causes reported on the remaining lines in Part 1 on the next lower lines.

### Example 1

- 1 (a) Ischaemic heart disease resulting in heart failure
  - (b) Diabetes
  - (c)
  - (d)
- 2

Code heart failure, which follows the connecting term 'resulting in', on line (a). Code ischaemic heart disease, which is reported before the connecting term, is moved to line (b). Move diabetes, reported on line (b), one line down and code it on line (c).

### Example 2

- 1 (a) Hepatocellular carcinoma causing heart failure
  - (b) Ischaemic heart disease
  - (c) Diabetes
  - (d)
- 2

Code heart failure reported after the connecting term 'causing', on line 1(a). Code hepatocellular carcinoma, which is reported before the connecting term, on line 1(b). Move ischaemic heart disease, reported on line 1(b), to line 1(c), and move diabetes, which is reported on line 1(c), to line 1(d). This applies to other connecting terms or signs that indicate a 'resulting in' relationship, such as 'causing', 'leading to', 'developing into', and similar.

## 2.21.2.2 Connecting terms not implying a causal relationship

### *'And' written or implied by a similar term first or last on a line*

The connecting term 'and' does not imply a causal relationship, but it indicates that the terms before and after it should be counted. Therefore, when a line ends with 'and', code the cause(s) mentioned on the line immediately below for this line, so that the coding reflects the enumeration implied by the connecting term. Similarly, when a line starts with 'and', consider this as a continuation of an enumeration starting on the line above, and code the cause or causes on that line last on the line above. Code any causes reported on the remaining lines in Part 1 where reported. This applies to other connecting terms or signs that indicate an enumeration but do not imply a causal relationship, such as 'also', 'plus', 'besides', 'in addition', '+' or comma.

### Example 1

- 1 (a) Heart failure and
  - (b) Ischaemic heart disease
  - (c) Diabetes
  - (d)
- 2

Line 1(a) ends with 'and', so consider 'ischaemic heart disease', reported on line (b) as a part of the enumeration 'heart failure and ischaemic heart disease'. Code accordingly and place the codes for both heart failure and ischaemic heart disease on line 1(a). Code diabetes on line (c).

### Example 2

- 1 (a) Heart failure
  - (b) Ischaemic heart disease
  - (c) and diabetes
  - (d)
- 2

Line 1(c) starts with 'and'. Consider diabetes, reported on line (c), as a part of the enumeration 'ischaemic heart disease and diabetes'. Code accordingly, and place the codes for both ischaemic heart disease and diabetes on line 1(b).

#### *'And' written or implied by a similar term but not first or last on a line*

If a connecting term that does not imply a causal relationship is written on a line but not first or last, then treat it as a comma. Do not reformat the text and do not move any part of the causes reported to another line.

#### *Diagnostic terms that do not stop at the end of the line*

If a diagnostic term starts on one line in Part 1 and continues on the next line, code as if the entire diagnostic term had been written on the line where the diagnostic term starts. Code any causes reported on the remaining lines in Part 1 where reported.

### Example 1

- 1 (a) Ischaemic
  - (b) Heart disease
  - (c) Diabetes type 2
  - (d)
- 2

'Ischaemic heart disease' is a diagnostic term reported on two lines. Code as if the complete term had been written on line (a). Code diabetes where it is reported, on line (c).

### Example 2

- 1 (a) Pneumonia
  - (b) Chronic kidney
  - (c) disease, diabetes type 2
  - (d)
- 2

'Chronic kidney disease' is a diagnostic term reported on two lines. Reformat the certificate and code the complete term 'chronic kidney disease' on line (b). Also code diabetes on line (b), since it continues the line where 'chronic kidney' has been written.

## 2.21.3 Duration of conditions

### 2.21.3.1 Single duration stated for multiple conditions

When more than one condition is reported in the same line with only one stated duration, consider that each condition reported had the same duration.

### 2.21.3.2 Modifying temporality of conditions by stated duration

Duration should not usually be used to qualify a condition as acute or chronic unless the Indexed Term provides specific duration criterium or it is otherwise instructed in the reference guide (e.g. Section [2.21.8.1 Acute or chronic rheumatic heart diseases](#)). Note that the Description in the classification is not to be used for coding (Section [3.4](#)).

### 2.21.4 'Code also' instructions in mortality use case

Generally, the 'code also' instruction (see also Section [2.7.2.1 'Code also' and 'Use additional code, if desired' instructions](#)) is not used in multiple cause coding since the information on aetiology is provided as a stand-alone expression separately on the death certificate and will be coded on its own, or is not provided at all.

Apply the 'Code also' instruction when both information on the manifestation and the aetiology appear in a single diagnostic term reported by the certifier, and information on the aetiology is not reported separately. Whenever applying the 'code also' instruction, put the code for the aetiology at the beginning of the cluster and add the code for the manifestation.

#### Example 1: Heart failure

[BD10-BD1Z](#) *Heart failure* has an instruction to 'Code also' the causing condition. However, in the diagnostic term reported by the certifier no information is given on such causing condition. Do not apply the 'Code also' instruction.

#### Example 2: Type 1 diabetic acidosis

[5A22](#) *Diabetic acidosis* has an instruction to 'Code also' the causing condition. The causing condition is reported, which in this case is [5A10](#) *Type 1 diabetes mellitus*. The aetiological condition Type 1 diabetes mellitus is considered the causing condition for primary tabulation and is coded first ([5A10](#) *Type 1 diabetes mellitus*/[5A22](#) *Diabetic acidosis*).

#### Example 3: Salmonella Sepsis

Salmonella sepsis is an index term of [1G40](#) *Sepsis without septic shock* which has an instruction to 'Code also' the causing condition supplemented by a coding note to code the type of infection first. The type of infection in this case is [1A09](#) *Infections due to other Salmonella* and is coded first ([1A09](#)/[1G40](#)).

### 2.21.5 Malignant neoplasms

To assign the correct multiple cause code for a neoplasm, there are two concepts to consider: whether the reported neoplasms is primary or secondary, and its behaviour.

The primary site is the anatomical location where the neoplasm originated. A malignant neoplasm may spread to other parts of the body, and these sites are referred to as a secondary or metastasis.

The behaviour (malignant, in situ, benign, uncertain or unknown) of a neoplasm is the way it spreads within the body:

- Malignant - the neoplasm invades surrounding tissue or disseminates from its point of origin and begins to grow at another site
- In situ - the neoplasm is malignant but still fully confined to the tissue in which it originated
- Benign - the neoplasm grows in the place of origin without the potential for spread
- Uncertain behaviour - A neoplasm displaying morphologic, phenotypic, or genotypic characteristics that are clearly not benign but do not permit the establishment of a definitive diagnosis of malignancy
- Unknown behaviour - it is unknown whether the neoplasm is benign or malignant.

The broad structure of Chapter 02 'Neoplasms' given below can be understood from these concepts as follows:

- Neoplasms of brain or central nervous system ([2A00-2A0Z](#))
- Neoplasms of haematopoietic or lymphoid tissues ([2A20-2B3Z](#))
- Neoplasms, except of lymphoid, haematopoietic, central nervous system or related tissues ([2B50-2F9Z](#))

Neoplasms originating in the brain or central nervous systems, classified to [2A00-2A0Z](#), are further classified by site, histopathology or behaviour.

Neoplasms originating in the haematopoietic or lymphoid tissues, classified to [2A20-2B3Z](#), are further classified by histopathology.

In other words, [2A00-2A0Z](#) or [2A20-2B3Z](#) includes primary neoplasms, which could be either malignant or benign.

Neoplasms originating in other sites are classified to ([2B50-2F9Z](#)) and this group is further classified by behaviour (i.e. malignant, in situ, benign, uncertain, or unknown), site or histopathology. Note that neoplasms originating in other sites and disseminating into the brain, central nervous system, lymphoid, haematopoietic tissues, are included here under the block of malignant neoplasm metastases.

In mortality coding, it is most important to determine the primary site of the neoplasm. When the death certificate is ambiguous as to the primary site, every effort should be made to obtain clarification from the certifier. The instructions that follow should be applied only when clarification cannot be obtained.

In the examples in this section, ICD codes are provided to the right of the death certificate. These codes represent the multiple cause codes assigned to each entry. These multiple cause codes could be different from a code assigned when the given diagnostic entry was reported alone on the certificate (direct coding). In such cases, the code for direct coding is given in curly brackets '{ }' next to the diagnostic expression. The explanation for each example describes that the codes in brackets will be modified by other information on the certificate (application of multiple cause coding) and to code to the multiple cause code indicated to the right.

### *Using the coding tool for neoplasms*

Using the ICD coding tool, search for the term reported on the certificate to describe the neoplasm. If both histopathology and site are stated, enter both into the coding tool. If the histopathology is incompatible with the stated site of the neoplasm (i.e. the neoplasm cannot be primary of the stated site according to textbooks and other reference literature), then assign a code for a neoplasm of unspecified site for the histopathology indicated. If the histopathology is not stated, code by site and behaviour, if reported.

Do not assign [2D43](#) *Malignant neoplasms of independent, multiple primary sites* when multiple neoplasms are mentioned. Code each malignant neoplasms by the coding tool, and select the underlying cause by applying the selection and modification rules in the normal way.

#### **2.21.5.1 Behaviour: malignant, in situ, benign, uncertain or unknown behaviour**

To assign the correct multiple cause code for a neoplasm, first determine behaviour (malignant, in situ, benign, uncertain or unknown) for each of the neoplasms reported on the death certificate. For malignant neoplasms, also determine whether to code them as primary or secondary. To that end, apply the instructions that follow.

##### *The term itself indicates behaviour*

First, use the coding tool to assign a code for terms used to describe the neoplasms. A specific histopathology or term may be assigned to a certain group of behaviour.

For neoplasms coded to the following categories, presume its behaviour is malignant, unless otherwise specified, and go to Section [2.21.5.2 Malignant neoplasms: primary or secondary?](#):

- [2A00-2A0Z](#) *Neoplasms of central nervous system or related structures*
- [2A20-2B3Z](#) *Neoplasms of haematopoietic or lymphoid tissues*
- [2A02.3](#) *Benign neoplasm of cranial nerves*

Note that the behaviour given by the coding tool for a specific term may change by other information on the certificate. Follow the instructions in this Section to decide the correct behaviour in multiple cause coding.

##### *Other information on the certificate indicates behaviour*

If the term used to describe the neoplasm does not indicate a specific behaviour, then look for other information on the certificate indicating behaviour. Code a neoplasm of unspecified behaviour, a neoplasm described as 'in situ', or a growth that is not coded to Chapter 02 (for example, certain polyps), as malignant if any of the conditions below apply:

- it is reported as the cause of secondary spread (terms such as infiltration, metastases, secondaries or similar) or of (malignant) cachexia, or;
- it is reported immediately beside a mention of secondary spread, or;
- all other neoplasms reported are specified as secondary spread, or;
- there is no mention of another neoplasm on the same part of the certificate, but there are other indications of malignancy reported anywhere on the certificate (for example, carcinosis, malignant cachexia, malignant transformation), or;
- it is reported as due to a malignant neoplasm.

If a neoplasm is coded to the Chapter 02 category for benign neoplasm but is reported as the cause of metastases or infiltration, check for a code for a malignant variety in the coding tool and in the tabular list. If found, code it as malignant. If there is no code for a malignant variety, first try to obtain clarification from the certifier. If no further information is available, then accept the statement on the certificate and code the neoplasm as benign.

If other information on the certificate indicates that a neoplasms is malignant, go to Section [2.21.5.2 Malignant neoplasms: primary or secondary?](#) to assign the correct code.

If there is no other information on the certificate that indicates behaviour, code as unknown behaviour.

#### Example 1

- 1 (a) Liver metastases [2D80.0](#)
- (b) Colon tumour {[2F90.0](#)} [2B90.Z](#)
- (c)
- 2

The colon tumour is reported as the cause of liver metastases so code as Malignant neoplasms of colon, unspecified ([2B90.Z](#)).

#### Example 2

- 1 (a) Cancer cachexia [MG20.0](#)
- (b) Colon tumour {[2F90.0](#)} [2B90.Z](#)
- (c)
- 2

The colon tumour is reported as the cause of malignant cachexia so code as Malignant neoplasms of colon, unspecified ([2B90.Z](#)).

#### Example 3

- 1 (a) Liver and lung metastases [2D80.0](#), [2D70](#)
- (b) Respiratory failure [CB41.2Z](#)
- (c) Colon tumour {[2F90.0](#)} [2B90.Z](#)
- 2

Both metastases and respiratory failure can be due to a colon tumour. According to the instructions on how to interpret causal relationships in Part 1 (Step SP3) this means that two valid causal relationships are reported on this certificate, 1) liver and lung metastases due to colon tumour, and 2) respiratory failure due to colon tumour. These relationships are valid even if liver and lung metastases cannot be due



to respiratory failure. The colon tumour is reported as the cause of secondary spread so code as Malignant neoplasms of colon, unspecified ([2B90.Z](#)).

#### Example 4

- 1 (a) Colon tumour {[2F90.0](#)} with liver metastases [2B90.Z](#), [2D80.0](#)
- (b)
- (c)
- 2

The colon tumour is reported on the same line as and next to liver metastases so code as Malignant neoplasms of colon, unspecified ([2B90.Z](#)).

#### Example 5

5

- 1 (a) Breast tumour, generalized atherosclerosis, [2F95](#), [BD40.Z](#),  
colon cancer with liver metastases [2B90.Z](#), [2D80.0](#)
- (b)
- (c)
- 2

The breast tumour is reported on the same line as but not next to secondary spread. Do not consider it malignant. Code as Neoplasms of unknown behaviour of breast ([2F95](#)).

#### Example 6

- 1 (a) Respiratory failure [CB41.2Z](#)
- (b) Colon tumour {[2F90.0](#)} [2B90.Z](#)
- (c)
- 2 Liver and lung metastases [2D80.0](#), [2D70](#)

All other neoplasms are specified as secondary spread so code colon tumour as Malignant neoplasms of colon, unspecified ([2B90.Z](#)).

#### Example 7

- 1 (a) Colon tumour {[2F90.0](#)} [2B90.Z](#)
- (b)
- (c)
- 2 Cancer cachexia [MG20.0](#)

There is no mention of another neoplasm but cancer cachexia, another indication of malignancy, is reported in Part 2 so code colon tumour as Malignant neoplasms of colon, unspecified ([2B90.Z](#)).

#### Example 8

- 1 (a) Bladder tumour [2F98](#)
- (b) Lung tumour [2F91.1](#)
- (c)
- 2

There is no information on the certificate that indicates behaviour, code bladder tumour as Neoplasms of unknown behaviour of urinary organs ([2F98](#)) and lung tumour as Neoplasms of unknown behaviour of trachea, bronchus or lung ([2F91.1](#)).

### 2.21.5.2 Malignant neoplasms: primary or secondary?

If a neoplasm is coded as malignant or its behaviour is presumed to be malignant by Section [2.21.5.1 Behaviour: malignant, in situ, benign, uncertain or unknown behaviour](#) above, next decide whether it is primary or secondary.

Sometimes malignant neoplasms are described as ‘metastatic’, which might refer either to a primary malignant neoplasm that has metastasized to another site, or to secondary malignant neoplasms originating somewhere else. For instructions on how to code neoplasms described as ‘metastatic’, see Section [2.21.5.6 ‘Metastatic’ cancer](#).

#### *Common sites of metastases*

When choosing between codes for primary and secondary malignant neoplasms, refer to the following list of common sites of metastases:

- bone ([2B5Z](#))
- brain ([2A00.5](#))
- diaphragm ([2B5K](#) & [XA2JL0](#))
- ill-defined site ([2D42](#))
- liver ([2C12.0Z](#))
- lung ([2C25.Z](#) & [XA57M6](#))
- lymph nodes ([2D60-2D6Z](#))
- mediastinum ([2C28.Z](#) & [XA7WA2](#))
- meninges ([2A01.2](#))
- peritoneum ([2C51.Z](#))
- pleura ([2C28.Z](#) & [XA5TT2](#))
- retroperitoneum ([2C50.Z](#))
- spinal cord ([2A02.2](#))
- omentum ([2C52.Z](#))

Note: these sites should be considered common sites of metastases, unless a specific histopathology is described.

See below for further instructions on how to code these neoplasms.

#### *Malignant neoplasm reported as primary*

Code a malignant neoplasm specified as primary if it is specified as ‘primary’, ‘primary in’, ‘originating in’, or other similar terms.

#### *Other indication of primary malignant neoplasm*

Code a malignant neoplasm as primary, although not described as primary by the certifier, if:

- all other malignant neoplasms on the certificate are specified as secondary or as metastases. This applies whether the site not specified as secondary or as metastasis is on the list of common sites of metastases.
- it is in the code range [2A20-2B3Z](#) *Neoplasms of haematopoietic or lymphoid tissues*: Code all malignant neoplasms of haematopoietic or lymphoid tissues as primary, unless the certifier specifies them as secondary;
  - *note*: A primary neoplasm of haematopoietic and lymphoid tissues may occur simultaneously with another primary neoplasm in the same code range.
- the site is not on the list of common sites of metastases.

If the site is on the list of common sites of metastases, code the malignant neoplasm as primary if:

- the histopathology indicates that it is primary of the reported site;
- it is described as caused by a known risk factor for malignant neoplasms of the stated site (To determine if the condition reported as causing the neoplasm is a known risk factor, check if it is mentioned as a risk factor of the site involved in textbooks or other reliable sources);
- it is the only malignant neoplasm mentioned on the death certificate, and it is not specified as 'metastatic':
  - *exception*: code malignant neoplasm of lymph nodes as secondary, even if it is the only reported neoplasm on the certificate, unless it is specified as primary;
  - *note*: if the only malignant neoplasm reported on the certificate is malignant neoplasm of liver, and it is not specified as either primary or secondary, then code it as primary;
- it is malignant neoplasm of lung, and all other malignant neoplasms mentioned on the certificate are on the list of common sites of metastases;
  - *exception*: code lung as secondary if another malignant neoplasm is reported in the same part of the certificate (Part 1 or Part 2) and this other malignant neoplasm is coded as a primary malignant neoplasm;
- it is malignant neoplasm of lung specified as bronchogenic or of bronchus.

Code a neoplasm of behaviour other than malignant as primary malignant if it is reported as causing secondary or metastatic spread. See '**Other information on the certificate indicates behaviour**' above.

- *exception*: If durations are stated, the secondary neoplasms must not have a longer duration than the presumed primary malignant neoplasm;
- *exception*: If morphologies are stated, the secondary and presumed primary malignant neoplasms must have the same histopathology.

Do not code a neoplasm of behaviour other than malignant as primary malignant if it is reported as the cause of another neoplasm that would not be coded as malignant. Do not assume malignancy or metastatic spread. Code both neoplasms according to the coding tool.

### Example 1

- 1 (a) Brain metastasis [2D50](#)
- (b) Lung tumour [2C25.Z](#)
- (c)
- (d)

2

The lung tumour caused brain metastasis so is coded as malignant. The other malignant neoplasms on the certificate is described as metastasis ([2D50](#)) so code the lung tumour as primary at [2C25.Z](#)].

### Example 2

- 1 (a) Cancer of pancreas [2C10.Z](#)
- (b) Cancer of stomach [2B72.Z](#)
- (c)
- (d)

2

Pancreas and stomach are not on the list of common sites of metastases so code both as primary at Malignant neoplasm of pancreas, unspecified ([2C10.Z](#)) and Malignant neoplasms of stomach, unspecified ([2B72.Z](#)).

### Example 3

- 1 (a) Cancer of liver and lung {[2C25.Z](#)} [2C12.02](#) [2D70](#)
- (b) Chronic hepatitis [DB97.2](#)
- (c)
- (d)

2

Chronic hepatitis increases the risk of primary liver cancer so code the liver cancer as primary at Hepatocellular carcinoma of liver ([2C12.02](#)). Code the lung cancer as secondary at Malignant neoplasm metastasis in lung ([2D70](#)), because the other malignant neoplasm reported in the same part of the certificate is coded as primary.

### Example 4

- 1 (a) Kidney cancer and lung cancer {[2C25.Z](#)} [[2C90](#)], [2D70](#)
- (b)
- (c)
- (d)

2

Code the kidney cancer as primary ([2C90.Z](#)) since it is not on the list of common sites of metastases. Code lung cancer as secondary at Malignant neoplasm metastasis in lung ([2D70](#)) since it is reported in the same part of the certificate as the kidney cancer and the kidney cancer is considered primary.

#### Example 5

- 1 (a) Liver tumour {[2F90.Y](#)} [2C12.02](#)  
(b)  
(c)  
(d)
- 2 Lung tumour, probably secondary [2D70](#)

Code both tumours as malignant, since the certifier described one of the two as secondary, which is evidence of malignant behaviour. Code the liver tumour as primary, since the other malignant neoplasm on the certificate is described as secondary. The qualification 'probably' is ignored; see Section [2.21.1 Uncertain diagnosis](#).

#### Example 6

- 1 (a) Metastatic involvement of chest wall [2E0Y](#)  
(b) Carcinoma in situ of breast {[2E65.Z](#)} [2C6Z](#)  
(c)  
(d)
- 2

Code the carcinoma in situ of breast as malignant because it is reported as the cause of secondary spread, and code as primary at Malignant neoplasms of breast, unspecified (2C6Z) as the other malignant neoplasm is described as secondary.

#### Example 7

- 1 (a) Secondary malignant neoplasm of lung and brain [2D70](#), [2D50](#)  
(b) Polyp of stomach {[DA44.Z](#)} [2B72.Z](#)  
(c)  
(d)
- 2

Code the polyp of stomach as malignant as it is reported as the cause of secondary spread, and code as primary at Malignant neoplasms of stomach, unspecified (2B72.Z) as all other malignant neoplasms are described as secondary.

#### Example 8

- 1 (a) Brain cancer (glioma) [2A00.0Z](#)  
(b)  
(c)  
(d)
- 2 Kidney cancer [2C90.Z](#)

Brain is on the list of common sites of metastases, but the histopathology glioma indicates that it is primary in brain. Code the brain cancer as primary at Gliomas of brain, unspecified (2A00.0Z). Kidney is not on the list of common sites so code as primary at Malignant neoplasms of kidney, except renal pelvis, unspecified (2C90.Z).

### Example 9

- 1 (a) Bone cancer (osteosarcoma) [2B51.Z](#)
  - (b) Colon cancer
  - (c)
  - (d) [2B90.Z](#)
- 2

Bone is on the list of common sites of metastases, but the histopathology osteosarcoma indicates that it is primary in bone. Code the bone cancer as primary at Osteosarcoma of bone and articular cartilage of unspecified sites (2B51.Z). Colon is not on the list of common sites so code as primary at Malignant neoplasms of colon, unspecified (2B90.Z).

### Example 10

- 1 (a) Brain cancer [2A00.5](#)
  - (b)
  - (c)
  - (d)
- 2

Brain is on the list of common sites of metastases, but it is the only malignant neoplasm mentioned on the certificate and is not described as metastatic. Code the brain cancer as primary at Primary neoplasm of brain of unknown or unspecified type (2A00.5).

### Example 11

- 1 (a) Cancer of cervical lymph nodes [2D60.0](#)
  - (b)
  - (c)
  - (d)
- 2

Lymph nodes are on the list of common sites of metastases, and it is the only malignant neoplasm mentioned on the certificate, but it is not described as primary. Code the cancer of cervical lymph nodes as secondary at Malignant neoplasm metastasis in lymph nodes of head, face or neck (2D60.0).

### Example 12

- 1 (a) Cancer primary in prostate [2C82.Z](#)
  - (b)
  - (c)
  - (d)
- 2

The cancer is described as primary in prostate. Code at Malignant neoplasms of prostate, unspecified (2C82.Z).

### ***Malignant neoplasm reported as secondary***

If the certifier describes a neoplasm as secondary, code as a secondary malignant neoplasm at Malignant neoplasm metastases (2D50-2E2Z). Use the coding tool to find the appropriate code.

### *Other indication of secondary malignant neoplasm*

Code a malignant neoplasm not specified as primary or secondary as secondary if:

- the site is on the list of common sites of metastases:
  - *exception*: if there is only one malignant neoplasm mentioned and it is not specified as 'metastatic', then code the neoplasm as primary. *note*: this does not apply to lymph nodes, which are always coded as secondary, even if it is the only reported neoplasm on the certificate, unless it is specified as primary.
  - *exception*: code lung as primary if all other sites in the same part of the certificate (Part 1 or Part 2) are on the list of common sites of metastases. However, code lung as secondary if one of the common sites of metastases reported on the same part of the certificate is considered primary, from its histopathology or by being described as caused by a known risk factor for malignant neoplasms of this site.
  - *exception*: code a malignant neoplasm on the list of common sites of metastases as primary, if all other malignant neoplasms on the certificate are specified as secondary or as metastases. This applies whether or not these other malignant neoplasms are on the list of common sites of metastases.
  - *exception*: code a malignant neoplasm on the list of common sites of metastases as primary, if the histopathology is stated and is compatible with the site. (To determine if a stated histopathology is compatible with the site, refer to textbooks or other reliable sources).
- unspecified whether primary or secondary, and the certifier states that the cancer is primary in another site. This applies whether or not the site is on the list of common sites of metastases:
  - regardless of site, do not code a neoplasm as secondary if it is of a different histopathology from another neoplasm stated to be primary. See also Section ['2.21.5.3 More than one primary malignant neoplasm'](#).
- unspecified whether malignant, in situ or benign, and it is reported as due to a malignant neoplasm:
  - *exception*: if durations are stated, do not code the unspecified neoplasm as secondary if it has a duration that is longer than the durations of the malignant neoplasm reported as the cause of the unspecified neoplasm.
- the histopathology indicates that the neoplasm cannot be primary of the stated site. In that case, use both the default code for a primary neoplasm of the histopathology involved and a code for a secondary malignant neoplasm of the stated site.

If all sites are on the list of common sites of metastases, then code all sites as secondary. It is recommended adding a code for unknown primary. Code to [2D4Z Unspecified malignant neoplasms of ill-defined or unspecified sites], if no histopathology is stated. If the histopathology is stated, then code to the 'unspecified site' code for the histopathology involved. - *exception*: If all sites are on the list of common sites of metastases but one of them is lung, then code lung as primary.

If the certificate states that the primary site was unknown, then code all neoplasm sites mentioned on the certificate as secondary. (See also Section [2.21.5.5 Primary site unknown](#)).

Do not use order of entry alone to determine whether a neoplasm specified as malignant is primary or secondary. Code a malignant neoplasm reported as due to another malignant neoplasm as secondary only if it is described as secondary, metastatic spread or similar, or if it is on the list of common sites of metastases.

Do not confuse 'primary' with 'primary in'. While 'primary in' identifies one of several malignant tumours of the same or unspecified histopathology as the primary tumour, 'primary' simply means that the malignant neoplasm was not secondary. It does not necessarily mean that all other malignant neoplasms mentioned on the certificate were secondary.

#### Example 1

- 1 (a) Carcinoma of adrenal glands {[2D11.Z](#)} [2E07](#)  
(b)  
(c)  
(d)
- 2 Primary in kidney [2C90.Z](#)

The malignant neoplasm of adrenal glands is considered secondary since the certificate states that the cancer was primary in kidney. Code the adrenal carcinoma as secondary at Malignant neoplasm metastasis in adrenal gland (2E07) and the primary in kidney as primary at Malignant neoplasms of kidney, except renal pelvis, unspecified (2C90.Z).

#### Example 2

- 1 (a) Prostate cancer {[2C82.Z](#)} [2E06](#)  
(b) Primary site unknown  
(c)  
(d)
- 2

The primary site is described as unknown. Code to Unspecified malignant neoplasms of ill-defined or unspecified sites (2D4Z). Code prostate cancer as secondary at Malignant neoplasm metastasis in male genital organs (2E06) since the primary malignant neoplasm clearly was in another site.

#### Example 3

- 1 (a) Brain tumour {[2A00.5](#)} [2D50](#)  
(b) Breast cancer [2C6Z](#)  
(c)  
(d)
- 2

Code the brain tumour as malignant, since it is reported as due to a malignant neoplasm breast cancer. Also, code as secondary at 2D50, since it is on the list of common sites of metastases. Code the breast cancer as Malignant neoplasms of breast, unspecified (2C6Z).



#### Example 4

- 1 (a) Brain tumour {[2A00.5](#)} [2D50](#)
  - (b) Lung cancer [2C25.Z](#)
  - (c)
  - (d)
- 2

Code the brain tumour as malignant, since it is reported as due to a malignant neoplasm lung cancer. Also code as secondary at Malignant neoplasm metastasis in brain (2D50)), since it is on the list of common sites of metastases and reported together with lung cancer. Code the lung cancer as primary at Malignant neoplasms of bronchus or lung, unspecified (2C25.Z), since the only other reported neoplasm is on the list of common sites of metastases.

#### Example 5

- 1 (a) Cancer growth in liver {[2C12.02](#)} and lymph nodes [2D80.0](#), [2D6Z](#)
  - (b)
  - (c)
  - (d)
- 2 Malignant neoplasm of stomach [2B72.Z](#)

Code the cancer growth in liver and lymph nodes as secondary, at Malignant neoplasm metastasis in liver (2D80.0) and at Metastatic malignant neoplasm to unspecified lymph node (2D6Z), respectively, since they are both on the list of common sites of metastases. Also code the stomach as primary at Malignant neoplasms of stomach, unspecified (2B72.Z).

#### Example

6

- 1 (a) Cancer of lung, pleura {[2C26.Z](#)} and chest wall [2C25.Z](#), [2D72](#),  
{[2D4Z](#)} [2E0Y](#)
  - (b)
  - (c)
  - (d)
- 2

Code the cancer of lung as primary at Malignant neoplasms of bronchus or lung, unspecified (2C25.Z), since the other sites mentioned on the certificate, pleura and chest wall, are on the list of common sites of metastases. Code cancer of pleura and chest wall as secondary at 2D72 and malignant neoplasm Malignant neoplasm metastasis in other specified sites (2E0Y), respectively.

#### Example 7

- 1 (a) Mesothelioma of pleura and lymph nodes [2C26.0](#), [2D60.Z](#)
  - (b)
  - (c)
  - (d)
- 2

Pleura is on the list of common sites of metastases but the histopathology mesothelioma indicates that it is primary in pleura. Code as primary at Mesothelioma of pleura (2C26.0). Code the malignant neoplasm of lymph nodes as secondary at [2D60.Z](#), since lymph nodes is on the list of common sites of metastases.

#### Example 8

- 1 (a) Cancer of bladder [2C94.Z](#)
  - (b) Cancer of kidney [2C90.Z](#)
  - (c)
  - (d)
- 2

Bladder and kidney are not on the list of common sites of metastases, and neither is described as primary, so code both as primary at Malignant neoplasms of bladder, unspecified (2C94.Z) and [2C90.Z](#) *Malignant neoplasms of kidney, except renal pelvis, unspecified*.

#### Example 9

- 1 (a) Osteosarcoma of sacrum [2B51.2](#)
  - (b) Clear cell cancer of kidney [2C90.Y](#)
  - (c)
  - (d)
- 2

Code both malignant neoplasms as primary. Bone is on the list of common sites of metastases but the histopathology osteosarcoma indicates that it is primary in sacrum. Code as a primary at Osteosarcoma of bone or articular cartilage of pelvis (2B51.2). Also, it is of different histopathology than clear cell cancer of kidney.

#### Example 10

- 1 (a) Osteosarcoma of lung [2B51.Z](#), [2D70](#)
  - (b)
  - (c)
  - (d)
- 2

The histopathology (osteosarcoma) indicates a primary neoplasm of bone, and the reported site (lung) is incompatible with the histopathology. Code as primary at Osteosarcoma of bone and articular cartilage of unspecified sites (2B51.Z), and add a code for Malignant neoplasm metastasis in lung (2D70).

### 2.21.5.3 More than one primary malignant neoplasm

If more than one primary malignant neoplasm is reported on the same certificate, code each primary malignant neoplasm as primary. Indications of more than one primary malignant neoplasms are:

- different histopathologies;
- a site-specific histopathology reported with a malignant neoplasm of another site that is not on the list of common sites of metastases;
- the sites are not on the list of common sites of metastases:

If one histopathology term is more specific and is an example of a more general histopathological term also reported on the certificate, then consider the two as referring to same neoplasm.

Do not consider 'cancer' a histopathologic term, but as synonym of 'malignant neoplasm'. On the contrary, 'carcinoma' is a histopathological term, describing a malignant tumour of epithelial origin.

#### Example 1

- 1 (a) Transitional cell carcinoma of bladder [2C94.2](#)
  - (b)
  - (c)
  - (d)
- 2 Osteosarcoma, primary in knee [2B51.1](#)

Bladder on line (a) is not on the list of common sites of metastases. The malignant neoplasm reported in Part 2 is specified as primary in knee but since the two neoplasms are of different histopathology, code both as primary at Urothelial carcinoma of bladder (2C94.2) and at Osteosarcoma of bone or articular cartilage of limbs (2B51.1), respectively.

#### Example 2

- 1 (a) Hepatoma [2C12.02](#)
  - (b) Cancer of breast [2C6Z](#)
  - (c)
  - (d)
- 2

Code hepatoma as primary at Hepatocellular carcinoma of liver (2C12.02), since the histopathology 'hepatoma' indicates a primary malignant neoplasm of liver. Code breast cancer as primary at Malignant neoplasms of breast, unspecified (2C6Z), since breast is not on the list of common sites of metastases.

#### Example 3

- 1 (a) Glioblastoma of brain [2A00.00](#)
  - (b) Cancer of breast [2C6Z](#)
  - (c)
  - (d)
- 2

Brain is on the list of common sites of metastases, but the histopathology glioblastoma indicates that it is primary in the central nervous system, usually in brain. Code glioblastoma of brain as primary at Glioblastoma of brain (2A00.00). Also code the breast cancer as primary at Malignant neoplasms of breast, unspecified (2C6Z), since breast is not on the list of common sites of metastases.

### 2.21.5.4 Site not clearly indicated

If a malignant neoplasm is described as in the 'area' or 'region' of a site, or if the site is prefixed by 'peri', 'para', 'pre', 'supra', 'infra' or similar expressions, then first check whether this compound term is included in the coding tool.

If the compound term is not in the coding tool, then code to the appropriate histopathology of the ill-defined site unspecified. Other specified malignant neoplasms of ill-defined or unspecified primary sites ([2D4Y](#)) is used for histopathologies specified but not classifiable elsewhere.

If neither of these apply, or the histopathology is not stated, then code to [2D42](#) *Malignant neoplasms of ill-defined sites*.

When the site of a primary malignant neoplasm is not specified, do not make any assumption of the primary site from the location of other reported conditions such as perforation, obstruction or haemorrhage. These conditions may arise in sites unrelated to the neoplasm. For example, intestinal obstruction may be caused by the spread of a malignant neoplasm of ovary.

Example 1

- 1 (a) Leiomyosarcoma in the region of the pancreas [2B58.Z](#)
- (b)
- (c)
- (d)
- 2

Code as Leiomyosarcoma, unspecified primary site (2B58.Z).

Example 2

- 1 (a) Cancer in the lung area [2C29.Z](#)
- (b)
- (c)
- (d)
- 2

Code as Malignant neoplasms of other or ill-defined sites in the respiratory system or intrathoracic organs, unspecified (2C29.Z)

Example 3

- 1 (a) Obstruction of intestines [DB30.Z](#)
- (b) Carcinoma [2D41](#)
- (c)
- (d)
- 2

Code the carcinoma as [2D41](#) Unspecified carcinoma of unspecified site (2D41)

### 2.21.5.5 Primary site unknown

If the certificate states that the primary site is unknown and does not mention a possible primary site or a specific histopathology, code to ([2D44](#)). If the primary site is unknown but a specific histopathology is stated code to the category for unspecified site for the histopathological type involved. For example, code adenocarcinoma to ([2D40](#)), and osteosarcoma to ([2B51.Z Osteosarcoma of bone and articular cartilage of unspecified sites]).

If the certificate mentions a probable or possible primary site, disregard the expression indicating doubt and code to that site. See also Section [2.21.1 Uncertain diagnosis](#).

If the certificate mentions several possible primary sites, select a code according to the instructions in Section [2.21.1.2 One condition, either one site or another](#) above.

Example 1

- 1 (a) Secondary carcinoma of liver [2D80.0](#)
  - (b) Primary site unknown [2D44](#)
  - (c)
  - (d)
- 2

The certificate states that the primary site is unknown. For line 1(b), code as [2D44](#).

Example 2

- 1 (a) Generalised metastases [2E2Z](#)
  - (b) Melanoma [2C30.Z](#)
  - (c) Primary site unknown [2D44](#)
  - (d)
- 2

The certificate states that the primary site is unknown, code to [2D44](#), Malignant neoplasm, primary site unknown, so stated. Code as [2C30.Z](#).

Example

3

- 1 (a) Secondary carcinoma of liver [2D80.0](#)
  - (b) Primary site unknown, [2B72.Z](#) *Malignant neoplasms of stomach, unspecified*
  - (c)
  - (d)
- 2

The certificate states that the primary site is unknown, but it also mentions stomach as a possible primary site. Ignore primary site unknown, 'possibly' and code line 1(b) as Malignant neoplasms of stomach, unspecified [2B72.Z](#) *Malignant neoplasms of stomach, unspecified*.

Example

4

- 1 (a) Secondary carcinoma of liver [2D80.0](#)
  - (b) Primary site unknown, probably stomach {[2B72.Z](#)} or colon [2C11.Z](#) {[2B90.Z](#)}
  - (c)
  - (d)
- 2

The certificate states that the primary site is unknown, but it also mentions stomach or colon as a possible primary site. Code line 1(b) as Malignant neoplasms of other or ill-defined digestive organs, unspecified (2C11.Z).

### 2.21.5.6 'Metastatic' cancer

Note: The expression 'metastatic' often poses a problem in the English language. Countries using languages other than English should translate only as much as needed of this section.

Neoplasms qualified as metastatic are always malignant. The adjective 'metastatic' can be used in two ways; mostly describing a primary tumour that has spread = metastasised to another site or organ (e.g. metastatic breast cancer), and sometimes describing the secondary site or location where the primary tumour has spread = metastasised (e.g. metastatic cancer in liver).

In the ICD-11 Foundation the adjective 'metastatic' followed by a site/organ (without a preposition) is always used in the meaning of a primary neoplasm of that particular site/organ that has spread into another site.

For multiple cause mortality coding, always follow the instructions in this section. This applies even if the coding tool indicates an ICD code for a 'metastatic' neoplasm or 'metastatic' disease other than the code you would arrive at by following these instructions. For example, the search might lead to a code in the section for 'malignant neoplasm metastases', but the multiple cause coding instructions might tell you to code the neoplasm as primary. If so, follow the instructions and code the neoplasm as primary.

#### *Malignant neoplasm 'metastatic from' a specified site*

If a malignant neoplasm is described as 'metastatic from' a specified site, or if a 'due to' relationship implies a spread from a specified site, code to primary of this site. This also applies to sites on the list of common sites of metastases. See Section [2.21.5.2](#) for the blocks used for primary malignant neoplasms.

#### *Malignant neoplasm 'metastatic to' a specified site*

If a malignant neoplasm is described as 'metastatic to' a specified site, or if a 'due to' relationship implies a spread to a specified site, code to secondary of this site, whether the site is on the list of common sites of metastases or not. Use a code in [2D50-2E2Z](#) 'Malignant neoplasm metastases' for this secondary site. However, if a histopathology is reported, code to the 'unspecified site' subcategory of that histopathological type.

#### *Malignant neoplasm metastatic of site A to site B*

A malignant neoplasm described as metastatic of site A to site B should be interpreted as primary of site A and secondary of site B.

#### *'Metastatic' neoplasm of a specific histopathology*

If the certificate reports a malignant neoplasm specified as 'metastatic' of a histopathological type classifiable to a cancer category that mentions a specific histopathology only, and the site reported is consistent with the histopathological type, then code to a primary malignant neoplasm of the specified histopathological type. Use the appropriate site subcategory for the specified histopathological type or site.

If the 'metastatic' cancer reported on the certificate and the site are not consistent with the histopathological type, then code to a secondary malignant neoplasm of the specified site.

Also add a code for a primary malignant neoplasm of unspecified site for the stated histopathological type.

When applying the remaining instructions on 'metastatic', do not change codes in [2A00-2A0Z](#) *Neoplasms of central nervous system or related structures*, [2B50-2B5Z](#) *Malignant mesenchymal neoplasms*, [2C30-2C3Z](#) *Malignant neoplasms of skin*, [2C40-2C4Z](#) *Malignant neoplasms of peripheral nerves or autonomic nervous system*, or assigned according to the instructions in this subsection 'Metastatic' neoplasm of a specific histopathology, to codes for secondary malignant neoplasms (2D50-2E2Z).

#### Example 1

- 1 (a) Osteosarcoma of sacrum, metastatic [2B51.2](#)
  - (b)
  - (c)
  - (d)
- 2

The site sacrum is consistent with a primary cancer of bone. Code as Osteosarcoma of bone or articular cartilage of pelvis (2B51.2).

#### *'Metastatic' malignant neoplasm on the list of common sites of metastases*

If the certificate mentions a single malignant neoplasm, and it is on the list of common sites of metastases and is specified as 'metastatic', then code the neoplasm as secondary, even if no other neoplasm is mentioned on the certificate. Also add a code for unspecified primary malignant neoplasm ([2D4Z](#)).

- *exception:* Code a neoplasm, even if described as 'metastatic', of a site on the list of common sites of metastases as primary when it is reported as due to a condition that increases the risk of a malignant neoplasm of that site or tissue.
- *exception:* If the only malignant neoplasm mentioned on the certificate is 'metastatic' neoplasm of lung, code to Malignant neoplasms of bronchus or lung, unspecified (2C25.Z). If another malignant neoplasm is mentioned that is not on the list of common sites of metastases, then code a 'metastatic' malignant neoplasm of lung as Malignant neoplasm metastasis in lung (2D70). This applies whether or not lung is mentioned in the same part of the certificate as the other malignant neoplasm.
- *exception:* For 'metastatic' neoplasms of a specified histopathology and on the list of common sites of metastases, see **'Metastatic neoplasm of a specific histopathology'** above.

Note that a malignant neoplasm of a site on the list of common sites of metastases is coded as primary if it is the only site mentioned and it is not described as 'metastatic'. See also **'Other indication of primary malignant neoplasm'** above.

### Example 1

1 (a) Metastatic cancer of lung (adenocarcinoma) [2C25.0](#)

(b)

(c)

(d)

2

Adenocarcinoma can be primary in lung. Lung is the only site mentioned or implied on the certificate. Code as primary malignant neoplasm of lung at Adenocarcinoma of bronchus or lung (2C25.0).

If the certificate mentions several malignant neoplasms that are on the list of common sites of metastases and one or more of them are specified as 'metastatic', then code all of them as secondary malignant neoplasms. Also add a code for unspecified primary malignant neoplasm [2D4Z](#).

- *exception:* Code a 'metastatic neoplasm of lung' as primary malignant neoplasm of the lung Malignant neoplasms of bronchus or lung, unspecified (2C25.Z) if all other neoplasm sites reported on the death certificate are on the list of common sites of metastases, whether they are described as 'metastatic' or not.
- *exception:* For 'metastatic' neoplasms of a specified histopathology' which are on the list of common sites of metastases, see subsection '**Metastatic malignant neoplasm of a specific histopathology**' above.

#### *'Metastatic' malignant neoplasm not on the list of common sites of metastases*

If the certificate mentions a single malignant neoplasm, and this neoplasm is not on the list of common sites of metastases but it is specified as 'metastatic', then code as primary malignant neoplasm of that particular site.

If the certificate mentions several malignant neoplasms that are not on the list of common sites of metastases and all of them are specified as 'metastatic', then code all neoplasms as primary.

If the certificate mentions several malignant neoplasms, and none of them is on the list of common sites of metastases and some but not all are specified as 'metastatic', then code a neoplasm not specified as 'metastatic' as primary and a neoplasm specified as 'metastatic' as secondary.

See Section [2.21.5.2 Malignant neoplasms: primary or secondary?](#) for blocks used for primary or secondary.

#### *'Metastatic' malignant neoplasm, some on the list of common sites of metastases and some not*

If the certificate mentions several malignant neoplasms and some but not all are on the list of common sites of metastases and some but not all are specified as 'metastatic', then code a neoplasm on the list of common sites of metastases as secondary ([2D50-2E2Z](#)). Also, code a neoplasm not on the list of common sites of metastases and specified as 'metastatic' as secondary, and a neoplasm not on the list of common sites of metastases and not specified



as 'metastatic' as primary (See Section [2.21.5.2](#) for the blocks used for primary malignant neoplasms).

- *exception*: Code neoplasms, even if described as 'metastatic', as primary when reported as due to a condition that increases the risk of a malignant neoplasm of that site or tissue, whether the site is on the list of common sites of metastases or not.

#### Example 1

- 1 (a) Liver cancer [2D80.0](#)  
(b) Metastatic colon cancer [2B90.Z]  
(c)  
(d)
- 2

Code as Malignant neoplasm metastasis in liver (2D80.0) and Malignant neoplasms of colon, unspecified (2B90.Z) . Liver is on the list of common sites of metastases but colon is not.

#### Example 2

- 1 (a) Metastatic gallbladder cancer [2C13.Z](#)  
(b) Metastatic colon cancer [2B90.Z](#)  
(c)  
(d)
- 2

Code both Malignant neoplasms of gallbladder, unspecified (2C13.Z) and Malignant neoplasms of colon, unspecified (2B90.Z) as primary. The order of entry does not affect the coding.

### 2.21.6 Sequelae

A sequela is a chronic condition resulting from an acute condition and which begins during that acute condition. The acute condition is itself no longer present.

The classification provides certain categories to be used when conditions are reported as sequelae, late effects, or other conditions specified in this section (e.g. [1G80-1G8Z Sequelae of infectious diseases](#)). Where no specific category is provided for the condition described as a sequela (e.g. late effects of injuries are coded to the residual category of the chapter that may also include acute conditions), use additional code [XT9C](#) Cause of late effect, if desired, to identify that the first condition was reported as a cause of a sequela condition (e.g. Head injury sequelae: NAOZ&XT9C Injuries to the head, unspecified & Cause of late effect).

Note: When deciding whether a condition is a sequela or late effect, the stated duration of all subsequent conditions should be taken into account.

Example 1	Duration
1	
(a) Aspiration pneumonia	
(b) Dysphagia	
(c) Stroke	1 year
(d)	
2	

Code stroke to the late effect of stroke, as it has caused something with a duration longer than the required time for stroke to be considered late effect.

### 2.21.6.1 Conditions considered to be sequelae

Consider the following categories present one year or more after onset of the previous condition as a late effect:

- [1G84](#) Sequelae of viral encephalitis
- [1G85](#) Sequelae of diphtheria
- [1G8Y](#) Sequelae of other specified infectious diseases
- [5B63](#) Sequelae of rickets
- [8B25](#) Late effects of cerebrovascular disease
- Late effects of injuries, of poisoning or of certain other consequences of external causes
- Late effects of external causes of morbidity or mortality

### 2.21.6.2 Sequelae of tuberculosis

Code tuberculosis ([1B10.0](#) -[1B10-1B1Z](#)) to sequelae of tuberculosis ([1G80](#)) if the condition is specified as such or as arrested, cured, healed, inactive, old or quiescent, or similar descriptions unless there is evidence of active tuberculosis. This does not include chronic tuberculosis, which should be coded as active infectious disease.

### 2.21.6.3 Sequelae of trachoma

Code trachoma ([1C23](#)) to sequelae of trachoma ([1G81](#)) if trachoma is specified as healed or inactive and certain specified sequelae, such as blindness, cicatricial entropion and conjunctival scars, unless there is evidence of active infection. It does not include chronic trachoma, which should be coded as active infectious disease.

#### 2.21.6.4 Sequelae of viral encephalitis, diphtheria or other specified infectious diseases

Condition	Active Codes	Sequelae Code
Viral encephalitis	<a href="#">1C80</a> , <a href="#">1C83</a> – <a href="#">1C8D</a>	<a href="#">1G84</a>
Diphtheria	<a href="#">1C17</a>	<a href="#">1G85</a>
Other specified infectious disease, except for acute rheumatic fever, and HIV	<a href="#">1A00</a> - <a href="#">1A9Z</a> , <a href="#">1B21</a> - <a href="#">1B2Z</a> , <a href="#">1B50</a> - <a href="#">1C16</a> , <a href="#">1C18</a> - <a href="#">1C22</a> , <a href="#">1C2Y</a> - <a href="#">1C2Z</a> , <a href="#">1C82</a> , <a href="#">1C8E</a> , <a href="#">1C8F</a> , <a href="#">1C8Y</a> , <a href="#">1G80</a>	<a href="#">1G8Y</a>

Code the above infectious disease to the appropriate sequelae code of the infectious condition if the condition is specified as such or as arrested, cured, healed, inactive, old or quiescent. Sequelae also include conditions present one year or more after onset of conditions classifiable to infectious disease categories, unless there is evidence of active disease. This does not include chronic infectious diseases, which should be coded as active infectious disease.

#### 2.21.6.5 Sequelae of malnutrition or certain specified nutritional deficiencies

Condition	Active Codes	Sequelae Code
Protein energy malnutrition	<a href="#">5B50</a> - <a href="#">5B54</a> , <a href="#">5B71</a>	<a href="#">5B60</a>
Vitamin A deficiency	<a href="#">5B55</a>	<a href="#">5B61</a>
Vitamin C deficiency	<a href="#">5B56</a>	<a href="#">5B62</a>
Rickets	<a href="#">5B57.0</a>	<a href="#">5B63</a>
Other specified nutritional deficiencies	<a href="#">5B57.1</a> – <a href="#">5B5K</a> , <a href="#">5B70</a> , <a href="#">5B7Y</a>	<a href="#">5B6Y</a>
Unspecified nutritional deficiencies	<a href="#">5B7Z</a>	<a href="#">5B6Z</a>

Code the above malnutrition or certain specified nutritional deficiencies to the appropriate sequelae code of malnutrition or certain specified nutritional deficiencies if the condition is stated to be a sequela or late effect of or as the cause of conditions present one year or more after onset of the condition. This does not include chronic malnutrition or nutritional deficiency, which should be coded to current malnutrition or nutritional deficiency.

#### 2.21.6.6 Late effects of Chapter 22 and Chapter 23

Code any injury, poisoning or certain other consequences of external causes (Chapter 22) or external causes of morbidity or mortality (Chapter 23) to late effects of injury, poisoning or certain other consequences of external causes or late effects of external causes of morbidity or mortality include those specified as such, or as sequelae, and those present one year or more after the acute injury or originating event. Code to the originating active condition or external cause and use additional code [XT9C](#) if desired to the cluster to retain the information that it was reported as a late effect.

#### 2.21.6.7 Sequelae of leprosy

Code leprosy ([1B20](#)) to sequelae of leprosy if leprosy is stated to be a sequela or late effect of leprosy, or if a chronic condition or a condition with a duration of longer than a year that is reported due to leprosy is reported.

### 2.21.6.8 Sequelae of poliomyelitis

Code poliomyelitis ([1C81](#)) to sequelae of poliomyelitis ([1G83](#)):

- if poliomyelitis is specified as such or as history (of) or old, or duration of onset is more than a year

or

- if a chronic condition or a condition with a duration of longer than a year that is reported due to poliomyelitis is reported.

### 2.21.7 Consistency between sex of patient and diagnosis

Most categories of ICD–11 apply to all persons without reference to sex. However, some diseases are more likely to occur in one biological sex. A list of those conditions is given in:

- [3.14 Annex C: Annexes for Mortality Coding](#)
- [3.14.11 List of categories limited to, or more likely to occur in, female persons](#)
- [3.14.12 List of categories limited to, or more likely to occur in, male persons](#)

When addressing cases of inconsistency between sex of patient and diagnosis reported, it is important to be aware of issues around gender identity. National legislation may regulate the recognition of gender identity or gender reassignment (sex-change) including protection of privacy. If there are special obligations to respect confidentiality around gender reassignment cases, these must be taken into account in the coding decisions and the onward dissemination of the coded data.

The general recommendation for handling the situation where there is an apparent inconsistency between sex and diagnosis reported follows. However, this is a general guideline which may not always be applicable because legal requirements vary among countries. It is recommended to manually check all cases of inconsistencies between sex of patient and diagnosis reported. When data processed automatically in line with guidelines below, these cases should be flagged for additional manual check.

If there might be an inconsistency between the sex of the deceased and the cause of death reported:

- check the information and make sure that no reporting error occurred. Further information may be available from the certifier or registration officials. If checking shows that either sex or diagnosis is an error, correct the one which is believed to be wrong.

If no further information is available and:

- it cannot be decided whether there is an error, or which of the two data items (sex and diagnosis) is the one that is wrong, retain the recorded sex and code to [MH14](#) Other ill- defined and unspecified causes of mortality\*.
- it appears that a gender reassignment case or similar situation is involved, retain the recorded sex and code if possible, to a substitute code which is similar to the reported diagnosis but not specific to either sex. For example, a neoplasm of sex-specific genital organs could be coded to [2D4Y](#) Other specified malignant neoplasms

of unspecified primary sites. If no suitable substitute code exists, code to [MH14](#) Other ill- defined and unspecified causes of mortality\*.

\*Consider adding a note to the statistics, specifying the number of cases recoded because of apparent inconsistencies between sex and cause, while taking into consideration confidentiality required in each country.

## 2.21.8 Specific instructions on other ICD categories

### 2.21.8.1 Acute or chronic rheumatic heart diseases

Rheumatic heart diseases are classified to Acute rheumatic fever with heart involvement (1B41) or to chronic conditions at fifth character 0 of *BB60-BC0Z Heart valve diseases*, or [BC20](#) Chronic rheumatic heart diseases, not elsewhere classified, *depending on whether the rheumatic process being described is active or inactive. If there is no statement that the rheumatic process was active or inactive at the time of death, code the following cardiac conditions as active ([1B41](#) Acute rheumatic fever with heart involvement)*:

- a cardiac condition reported as due to rheumatic fever, except cardiac arrest, acute heart failure, bacterial endocarditis;
- a cardiac condition specified as rheumatic and described as acute or subacute;
- carditis, endocarditis, heart disease, myocarditis or pancarditis, described as rheumatic or reported as due to a rheumatic disease, and the duration is less than one year;
- carditis, endocarditis, heart disease, myocarditis or pancarditis, described as rheumatic or reported as due to a rheumatic disease, and the deceased is less than 15 years old.

### 2.21.8.2 Obstetric death of unspecified cause, Obstetric deaths 42 days–1 year after delivery, sequelae of obstetric causes

The International form of medical certificate of cause of death (See Mortality Annex [3.14](#) is structured to allow reporting on obstetric causes, the time elapsed between the obstetric event and the person's death, and whether the pregnancy contributed to death. Use all information available on the death certificate. When information provided is ambiguous it is recommended to verify where possible, while means of verification may vary among countries according to different legal systems or profiles in maternal mortality. Additional information may be obtained through clinical summaries of medical institutions, verbal autopsy reports, or by certain verification processes which may require not only queries to the certifier but also establishing an inquiry system to analyse specific cases.

Following concepts related to statistical tabulation of maternal mortality is provided in Section [2.25.5](#) Standards and reporting requirements related for maternal mortality.

- [2.25.5.1](#) Maternal death
- [2.25.5.2](#) Late Maternal death
- [2.25.5.3](#) Comprehensive maternal death
- [2.25.5.4](#) Direct and indirect obstetric deaths
- [2.25.5.5](#) Death occurring during pregnancy, childbirth and puerperium
- [2.25.5.6](#) Recording requirements of maternal mortality
- [2.25.5.7](#) International reporting of maternal mortality
- [2.25.5.8](#) Numerator, denominator, and ratios of published maternal mortality

Briefly the underlying cause of death categories for Maternal Mortality is summarized in the table below:

	<a href="#">JB00</a> - <a href="#">JB60</a> , <a href="#">JB63</a> .-, <a href="#">JB64</a> .-, <a href="#">JB6Y</a> , <a href="#">1C14</a> <b>Maternal death</b>	<a href="#">JB61</a> .- <b>Late Maternal death</b>	<a href="#">JB62</a> .- <b>Sequealae of obstetric conditions</b>
Decesed was pregnant:	at the time of death, and within 42 days before the death	more than 42 days but less than one year before the death	one year or more before the death

On a death certificate usually the timespan is recorded in day unit where 42 days are included in maternal death and 43 days are included in late maternal death. In a mathematical explanation, this means exactly 42 days are included in maternal death, while for example 42 days and one hour is included in late maternal death. Also note that [JB61](#).- and [JB62](#).- includes deaths due to any obstetric cause. The obstetric cause reported including cause unknown ([JB60](#)) is postcoordinated to [JB61](#).- or [JB62](#).- to retain information on the cause. Coding instructions are provided to select the UCOD and capture further details in a cluster.

### ***Coding instructions for maternal mortality***

For coding of maternal mortality, follow the general coding instructions.

To assign the correct multiple cause code for a certificate with mention of pregnancy, first use the coding tool to assign a specific code for each condition reported. Categories out of Chapter 18 may also be assigned. When a condition suggests it is an obstetric condition, by using certain modifiers such as 'obstetric' or 'maternal', search if there is a direct match of the diagnosis reported. The coding tool also supports coding by providing the icon 'J' ( ) for certain condition that have a compatible category for maternal conditions.

### Example 1

- 1 (a) Pulmonary oedema [CB01](#)
  - (b) Mitral valve insufficiency, pregnancy [JB64.4/BB61.Z](#)
  - (c)
  - (d)
- 2

Mitral valve insufficiency nos is coded to [BB61.Z](#), however assign [JB64.4/BB61.Z](#) because it is described as 'pregnancy'.

### Example 2

- 1 (a) Pulmonary oedema [CB01](#)
  - (b) Mitral valve insufficiency [BB61.Z](#)
  - (c)
  - (d)
- 2 XX completed weeks of gestation

Code mitral valve insufficiency to [BB61.Z](#). Pregnancy is mentioned in Part 2 and it is considered that pregnancy contributed to death. Apply Step M4 and code the underlying cause of death to [JB64.4](#) Diseases of the circulatory system complicating pregnancy, childbirth or the puerperium. For greater specificity, also add the code for [BB61.Z](#) Mitral valve insufficiency, unspecified to the cluster ([JB64.4/BB61.Z](#)).

### **Structure of Chapter 18 and other related categories**

The following categories are used for deaths due to an obstetric event occurring within 42 days after termination of pregnancy:

- [JA00 - JB4Z, 1C14](#): Direct obstetric causes
- [JB63.-, JB64.-](#): Maternal diseases classifiable elsewhere but complicating pregnancy
- [JB60](#) is used when a woman dies during pregnancy, labor, delivery or the puerperium and the only information provided is 'maternal' or 'obstetric' death. If obstetric cause of death is specified, do not use [JB60](#) but code to the appropriate category.
- [JB6Y](#) is used for other specified obstetric conditions not elsewhere classified

Category [JB61.-](#) is used for death of a woman due to an obstetric cause but more than 42 days but less than one year after termination of pregnancy.

Category [JB62.-](#) is used for death of a woman due to an obstetric cause of one year or more after termination of pregnancy.

[JB6Z](#) is used when both obstetric condition is unspecified, and the time elapsed between the obstetric event and death is unknown. Note that this code is not to be used for underlying cause of death (See section [2.19.4](#) Special instructions on surgery and other medical procedures (Step M4)) .

### **Determining whether pregnancy contributed to death**

Consider pregnancy contribute to death when pregnancy, puerperium or childbirth is reported in Part 1 or Part 2; or is reported elsewhere and the answer to the question “Did the pregnancy contribute to death?” is yes, unknown, or is unstated.

### ***Determining the time elapsed***

The time elapsed between the obstetric event and the death is determined by the duration reported for the obstetric cause. If duration is unknown or unspecified, use the information in Frame B of the death certificate. When duration is unknown or unstated, but pregnancy contributed to death, it is assumed that the death occurred within 42 days after the obstetric event.

### **2.21.8.3 Deaths due to Certain conditions originating in the perinatal period**

Chapter 19 ‘Certain conditions originating in the perinatal period’ includes conditions that have their origin in the perinatal period even though death or morbidity occurs later.

For decedents less than 28 days old, assume that a reported condition developed in the perinatal period, unless the duration is stated, and the onset was after the first completed week of life.

Use a code from Chapter 19, if:

- the condition is included in Chapter 19.
- the condition is specified as congenital/perinatal/newborn.
- the duration of the condition indicates that the condition developed in the neonatal or perinatal period. This applies even if the condition is not specified as neonatal or perinatal on the certificate.

Some conditions originating in the perinatal period are excluded from Chapter 19, such as:



- Intestinal infectious diseases ([1A00-1A40.Z](#))
- Congenital syphilis ([1A60](#))
- Congenital gonococcal infection ([1A70-1A70-1A7Z](#))
- Tetanus neonatorum ([1C15](#))
- HIV disease ([1C60-1C62.Z](#))
- Infectious diseases([1A00](#)-[1H0Z]), acquired after birth
- Neoplasms ([2A00-2F9Z](#))
- Hereditary haemolytic anaemia ([3A10](#))
- Transient hypogammaglobulinaemia of infancy ([4A01.03](#))
- Endocrine, nutritional and metabolic diseases ([5A00-5D46](#))
- Certain congenital diseases of the nervous system ([8A00-8E7Z](#))
- Endocardial fibroelastosis ([BC43.3](#))
- Intestinal obstruction or paralytic ileus ([DA93.0](#))
- Pemphigus neonatorum and Staphylococcal scalded skin syndrome ([EA50](#))
- Cradle cap ([EH40.00](#))
- Diaper (napkin) dermatitis ([EH40.10](#))
- Developmental anomalies ([LA00-LD9Z](#))
- Injury, poisoning and certain other consequences of external causes ([NA00-NF2Z](#))

For some conditions diagnosed under a specific age, it is assumed that the condition was congenital. See the following section, 'Developmental anomalies'.

*Fetus or newborn affected by maternal factors or by complications of pregnancy, labour or delivery*

Conditions of the mother affecting the fetus or newborn are to be reported in Part 1 or Part 2 of the death certificate and should, where possible, be coded to [KA00-KAOZ](#) Fetus or newborn affected by maternal factors or by complications of pregnancy, labour or delivery.

When a specified maternal condition affecting the fetus or newborn is initially coded outside Chapter 19 by the coding tool, code to [KA00-KAOZ](#). Also use additional code if desired to identify the specific maternal condition reported.

Consider a condition as maternal if it is specified as such, or if the term itself indicates it is a maternal condition (e.g. obstetric haemorrhage), or additional information reported in Frame B: Other medical data, suggests the condition is maternal.

Example 1

- 1 (a) Prematurity [KA21.4Z](#)
- (b) Cervical incompetence [KA01.0](#)
- (c)
- (d)

2

The maternal condition, cervical incompetence, affected the newborn by causing prematurity. The code provided by the coding tool is [GA15.6](#) which is outside Chapter 19. However, there is an exclusion note for

fetus or newborn affected by incompetence of cervix uteri. So, code to [KA01.0](#) Fetus or newborn affected by incompetence of cervix uteri.

The following table provides codes for certain maternal conditions and the corresponding codes for these conditions when affecting the fetus or newborn. Note that there are conditions not listed but are still coded to [KA00-KA0Z](#). For example, maternal chemotherapy or surgical procedure on mother may not be assigned a code but still can be classified to [KA00.9](#) and [KA00.A](#) respectively.

## Maternal conditions

[JA20-JA2Z](#) Oedema, proteinuria, or hypertensive disorders in pregnancy, childbirth, or the puerperium, except [JA22](#)

[JA22](#) Gestational oedema or proteinuria without hypertension

[GB40-GC2Z](#) Diseases of the urinary system

Chapter 01 Certain infectious or parasitic diseases

[DA0C](#) Periodontal disease

Chapter 12 Diseases of the respiratory system, or [LA70-LA7Z](#) Structural developmental anomalies of the respiratory system

[5B50-5C3Z](#) Nutritional disorders

Chapter 22 Injury, poisoning or certain other consequences of external causes

[JB64.0](#) Anaemia complicating pregnancy, childbirth or the puerperium

[GA15.6](#) Incompetence of cervix uteri

[JA01](#) Ectopic pregnancy

[JA40-JA4Z](#) Obstetric haemorrhage

[JA80](#) Maternal care related to multiple gestation

[JA87](#) Maternal care related to polyhydramnios

[JA88.0](#) Oligohydramnios

[JA89](#) Maternal care related to premature rupture of membranes

[JA8A](#) Maternal care related to placental disorders - [JA8C](#) Maternal care related to premature separation of placenta

[JB08](#) Labour or delivery complicated by umbilical cord complications

## Code to:

[KA00.0](#) Fetus or newborn affected by maternal hypertensive disorders

[KA00.1](#) Fetus or newborn affected by gestational oedema or proteinuria without hypertension

[KA00.2](#) Fetus or newborn affected by maternal renal or urinary tract diseases

[KA00.3](#) Fetus or newborn affected by maternal infectious diseases

[KA00.4](#) Fetus or newborn affected by periodontal disease in mother

[KA00.5](#) Fetus or newborn affected by maternal respiratory diseases

[KA00.6](#) Fetus or newborn affected by maternal nutritional disorders

[KA00.8](#) Fetus or newborn affected by maternal injury

[KA00.B](#) Fetus or newborn affected by maternal anaemia

[KA01](#) Fetus or newborn affected by maternal complications of pregnancy

[KA01](#) Fetus or newborn affected by maternal complications of pregnancy

[KA01](#) Fetus or newborn affected by maternal complications of pregnancy

[KA01](#) Fetus or newborn affected by maternal complications of pregnancy

[KA01](#) Fetus or newborn affected by maternal complications of pregnancy

[KA01](#) Fetus or newborn affected by maternal complications of pregnancy

[KA01](#) Fetus or newborn affected by maternal complications of pregnancy

[KA02](#) Fetus or newborn affected by complications of placenta

[KA03](#) Fetus or newborn affected by complications of umbilical cord

**Maternal conditions**

[JA88](#) Maternal care related to certain specified disorders of amniotic fluid or membranes, except [JA88.0](#)

[JB00-JB0Z](#) Complications of labour or delivery

**Code to:**

[KA04](#) Fetus or newborn affected by other abnormalities of membranes

[KA05](#) Fetus or newborn affected by certain complications of labour or delivery

#### 2.21.8.4 Special instructions on fetal deaths

Some international agencies require data on both live births and fetal deaths, but others do not include fetal deaths in their mortality statistics. Therefore, if fetal deaths are included in the national mortality register, they must be easy to identify, so that data include or do not include fetal deaths as requested by the agency to which the data will be delivered.

If it is not clear whether the death certificate relates to a fetal death or a child born alive, refer back to the certifier if possible. If the certifier confirms that it was a case of fetal death, or if other evidence points to a fetal death, then flag the death as a fetal death in the mortality statistics. If no cause of death is stated, code to [KD3B.Z](#) Unspecified time of fetal death, cause not specified.

If the certifier states that the child was born alive but does not report the cause of death, then code to [KD5Z](#) Conditions originating in the perinatal or neonatal period, unspecified.

Refer to [2.25.4.2](#) for the definitions of live birth and fetal death.

#### 2.21.8.5 Developmental anomalies

Conditions classified as Developmental anomalies should be coded as congenital if the duration of the condition indicates that it existed from birth, even if the condition is not specified as congenital on the death certificate. This applies to all conditions for which a specific congenital code is available, whether or not the code is in Chapter 20. Refer to the coding tool for the appropriate code for the condition with the modifier 'congenital'.

Further, the following conditions should be coded as congenital at the ages stated, provided there is no indication that they were acquired after birth:

- Under 1 year of age
  - aneurysm
  - aortic stenosis
  - atresia
  - atrophy of brain
  - cyst of brain
  - deformity
  - displacement of organ
  - ectopia
  - hypoplasia of organ
  - malformation
  - pulmonary stenosis
  - valvular heart disease
- Under 4 weeks of age
  - heart disease NOS
  - hydrocephalus NOS

#### 2.21.8.6 Multiple injuries in the same body region and Injuries involving multiple body regions

In multiple cause coding, do not use codes for multiple injuries of the same body region 'Multiple injuries of specific sites' ([NA00-ND1Z](#)) or codes for [ND30-ND37](#) *Injuries involving multiple body regions*, if specific information on the injuries involved is available. Code each injury separately and use as specific injury codes as possible. The information on multiple injuries is obtained in the multiple cause code string as a set of specific injury codes.

#### 2.21.8.7 Complications of surgical and medical care

There is a short list of specific complications not elsewhere classified in Chapter 22, ([NE8Z](#)). Early complications and conditions arising from devices, implants or grafts are coded here. Code late complications and longstanding complications of organ function to the postprocedural section in the appropriate system chapter.

#### 2.21.8.8 Intent of external causes

##### *Undetermined intent*

The block for undetermined intent ([PF40-PH8Z](#)) covers events where available information is insufficient to enable a medical or legal authority to make a distinction between unintentional causes, intentional self-harm or assault ([[PA00-PF2Z](#)]). The following cases are included:

- When external causes are reported as the intent could not be determined
- When self-inflicted injuries are reported without specification of intent

Note that self-inflicted poisonings reported without specification of intent are assumed to be unintentional and are coded to [PB20-PB36](#) *Unintentional exposure to or harmful effects of substances*.

Note that reporting of the intent may be affected by legal provisions in each country or region - assignment of codes should follow such provisions where appropriate.

#### 2.21.8.9 Coding of transport injury events

See Section [2.23.19](#) for descriptions on transport injury events.

1. *Land transport injury events can be “road traffic” or “off-road nontraffic”. Consider it as a road traffic injury event unless one of the following is true, in which case consider it as an off-road nontraffic injury event:*

- - a) Place of occurrence was stated explicitly as off-road or non-traffic
- - b) Place other than a public street or highway is specified
- - c) Only pedestrians or animals were involved

Special vehicles (see [2.23.19.1](#) categories u, v, w and x) are an exception to this rule. If the place of occurrence (on-road or off-road) is not available, and it is unknown whether the special vehicle type primarily operates on-road or off-road in your country or setting, code to categories in “Unintentional land transport injury event unknown whether road traffic or off-road nontraffic.

2. *When unintentional injury involving more than one kind of transport is reported, use the following order of precedence:*
  - aircraft and spacecraft
  - watercraft
  - other modes of transport
3. *When a land transport injury event description does not specify the role of person injured:*
  - *Consider the person injured as a pedestrian, if the person injured is described as crushed, dragged, hit, injured, killed, knocked down, or run over by any vehicle.*
  - *If not, consider the person injured as an occupant or rider of the vehicle mentioned.*
4. *When more than one vehicle is mentioned, do not make any assumption as to which vehicle was occupied by the person injured unless the vehicles are of the same type. Instead, code to the appropriate categories, taking into account the order of precedence given in note 2 above.*

#### 2.21.8.10 Factors influencing health status or contact with health services

This chapter should not be used for international comparison or for primary mortality coding (that is, as the underlying cause of death). Codes in the chapter may be added as multiple cause codes.

#### 2.21.8.11 Infectious agents reported alone on a death certificate

When an infectious agent is reported alone on a death certificate and if no Index Term is found for the infection of the infectious agent, refer to Chapter X and code to the infection of unspecified site of the most detailed parent of the infectious agent.

### Example 1

- 1 (a) Adenovirus [1D90](#)
  - (b)
  - (c)
  - (d)
- 2

Adenovirus is an infectious agent classified to [XN000](#). Code to [1D90](#) **Adenovirus infection of unspecified site**.

### Example 2

- 1 (a) Staphylococcus aureus [1C41](#)&[XN6BM](#)
  - (b)
  - (c)
  - (d)
- 2

Staphylococcus aureus is an infectious agent classified to [XN6BM](#). There is no Index Term for infection by staphylococcus aureus. Code to the infection of its most detailed parent Staphylococcus, [1C41](#) **Bacterial infection of unspecified site** and add [XN6BM](#) to identify the specific infectious agent reported.

### Example 3

- 1 (a) Escherichia Coli [1C41](#)&[XN6P4](#)
  - (b)
  - (c)
  - (d)
- 2

Escherichia Coli is an infectious agent classified to [XN6P4](#). There is no Index Term for infection by 'Escherichia Coli', and nor for its parents [XN4WC](#) Escherichia and [XN5PZ](#) Gram Negative Bacteria. Code to the infection of its most detailed parent Bacteria at [1C41](#) **Bacterial infection of unspecified site**, and add [XN6P4](#) to identify the specific infectious agent reported.

## 2.22 Mortality digital end to end solution (forms, tools and training modules)

### electronic Medical Certificate of Cause of Death (eMCCD)

The medical certificate of cause of death is the basis for collecting information on causes of death. The form is designed to collect all relevant aspects to assigning the cause of death and is independent of the revision of ICD. In addition to the paper form template in section [3.14](#), the technical specifications for a digital form are made available. The specifications serve to standardize input in line with the standard form and include a data dictionary for field names and content-encoding that allows processing the content with the API for coding, as well as with software for selection of the single underlying cause of death.

### Digital tools for the Cause of Death

Coding software for mortality consists of programs that assist in coding, selecting the single underlying cause of death and assessing the quality of the coding or the quality of the data at the population level.

The WHO Digital Open Rule Integrated Cause of Death Selection (DORIS) software assists in the selection of the underlying cause of death selection. It can be used online and offline. The ICD mortality rules detailed in section [2.21](#) were converted into a digital format for processing by this software. WHO is aiming at convergence in the different efforts in programming such software.

### **Analysing Mortality and Causes of Death 3 (ANACOD-3)**

This software performs a comprehensive and systematic analysis of mortality and cause-of-death data. ANACoD3 analyzes sub-national level data to inform of potential health equity issues or outbreak patterns; it also analyzes data over multiple time periods for trend analyses and allows for the analysis of cause-of-death data coded in ICD-10 as well as ICD-11 formats. It is available in multiple languages. For assistance in using the tool, please send an email to [mortality@who.int](mailto:mortality@who.int).

### **CodEdit**

Software that helps producers of cause-of-death statistics in strengthening their capacity to perform routine plausibility checks on their coding of data. Allows for the analysis of cause-of-death data coded in ICD-10 as well as ICD-11 formats

### **WHO Interactive self-learning tool**

The WHO electronic training tool is designed for self-learning and classroom use. The modular structure of this training permits user groups specific tailoring of courses on individual paths if desired. There are two mortality related modules of the training tool.

### **Certification self-learning module**

A training module using the cause of death certificate version for persons that fill in causes of death on a death certificate.

### **Recommendations for conducting an external inspection of a body module and how to fill in a death certificate**

A document providing recommendations for conducting an external inspection of a body and filling in the medical certificate of cause of death (MCCD) using the WHO 2016 international medical certificate of cause of death.

Other software or tools can be accessed through <https://www.who.int/standards/classifications> or <https://icd.who.int>

## **2.23 Main uses of the ICD: Morbidity**

Morbidity data are used for statistical reporting mostly at national or local levels. While some of this statistical reporting is conducted within an academic research context, it is commonly conducted in applied settings to inform health system and public health agency decision-making. ICD coded data also forms the basis of different casemix systems such as different varieties of Diagnosis Related Groups (DRGs). Coded morbidity data can also be used to inform a variety of clinical guidelines through provision of foundational information on burden of disease. The rules given here are primarily for international reporting and analysing purposes but are also recommended as a standard for national use.



### 2.23.1 ICD use in clinical care

Clinical care comprises different levels of treatment, all of which mean a level of diagnostic capacity that is higher than in primary care. The ICD addresses this level of detail primarily through multidimensional coding. Secondary care refers to the health care services provided by medical specialists and other health professionals who generally do not have first contact with patients, for example, cardiologists, urologists, or dermatologists. It includes acute care, necessary treatment for a short period of time for a brief but serious illness, injury or other health condition, such as in a hospital emergency department. It also includes skilled attendants during childbirth, intensive care, and medical imaging services. 'Secondary care' is sometimes used synonymously with 'hospital care'. However, many secondary care providers do not necessarily work in hospitals, such as psychiatrists, clinical psychologists, or physiotherapists, and some primary care services are delivered within hospitals. Depending on the organisation and policies of the national health system, patients may be required to see a primary care provider for a referral before they can access secondary care. Tertiary care refers to specialised consultative health care, usually for inpatients and following a referral from a primary or secondary health professional, in a facility that has personnel and facilities for advanced medical investigation and treatment, such as a tertiary referral hospital.

### 2.23.2 ICD use for epidemiological purposes

Epidemiology is the study of the distribution and determinants of health-related states or events (including disease) and the application of this study to the control of diseases and other health problems. Various methods can be used to carry out epidemiological investigations- surveillance and descriptive studies are used to study distribution and analytical studies are used to study determinants. ICD coded data, either from morbidity or mortality sources, contribute to the understanding of the health of a population.

### 2.23.3 ICD use in quality and patient safety

Coded health information is used to measure and report on various aspects of quality of care and patient safety (e.g. reporting on in-hospital mortality or adverse event rates for various conditions or reporting on patient safety indicators). Users of this kind of health information are health system payers (e.g. ministries of health, or in privately-funded health care systems, health insurance companies) and other stakeholders, such as health quality councils, hospital administrators, clinical leaders/groups, or public advocacy organisations.

#### 2.23.3.1 The quality and safety use case for ICD-11

The quality and safety use case of the ICD is based on the availability of large numbers of methodological tools that are originally based on ICD-10. Specific examples include the Charlson and Elixhauser co-morbidity indices, AHRQ (Agency for Healthcare Research and Quality) Patient Safety Indicators, the Hospital Standardised Mortality Ratio, and various other administrative data quality indicators. WHO recommendations on coding rules for hospital separation episodes improve comparability of records across hospitals and jurisdictions. Specific examples of coding rules include: a) rules for specifying the main condition, b) numbers of codes per record, c) code clustering mechanisms, and d) use of a status display system that distinguishes diagnoses arising during a hospital stay from those present at admission. Quality and patient safety reporting is often focused not only on

diagnostic information available in the International Classification of Diseases, but also on procedure information, that is currently coded in various country-specific procedure coding systems. The harmonisation of ontological concepts in international procedure coding systems will be important going forward. The available medical and surgical complication codes of ICD–11 are in line with current knowledge in the domain of safety and adverse events.

### **2.23.3.2 Reporting on indicators of quality of care and patient safety**

This use case relates to the use of coded health information to measure and report on various aspects of quality of care and patient safety (e.g. reporting on in-hospital mortality or adverse event rates for various conditions, or reporting on patient safety indicators). The initiating actor may be a health quality council, hospital administrators, clinical leaders/groups, a health system payer (e.g. ministries of health, or in privately-funded health care systems, health insurance companies) or a public advocacy ‘watch-dog’ organisations. The participating actors are hospital administrators, clinicians, health system decision makers, public representatives, patients and their families, and sometimes even the media. Requirements for reporting of quality and safety data are: - Availability of person-level data on episodes of health care delivery (e.g. hospitalisations, physician visits) - Identifiers that permit attribution of the health care delivery episode to a provider, provider group, or a given health facility/hospital. - Clinical information on diagnoses present and procedures performed during a health care delivery episode. - Clinical information on relevant outcomes such as mortality, length of stay, and specific adverse events. - Analytical expertise among initiating actors so that attention is paid to data validity considerations, knowledge of ‘best’ indicators (e.g. the most valid patient safety indicators), risk adjustment methodology, etc.

The outputs are reports containing information on dimensions of system quality. These can either provide global information on system performance, or comparative information stratified by provider unit (e.g. physician-level, hospital-level, or regional reporting).

### **2.23.3.3 Functionality:**

An ideal course of events for such use would include: - The initiating actor communicates desire to conduct quality/safety measurement and reporting to relevant stakeholders. - Appropriate applications are made to secure access to the data needed to conduct the planned reporting. - Appropriate methodological and clinical expertise is enlisted to ensure that best methodological practices are incorporated into the planned reporting, and that clinical face validity and acceptability are considered. - Data analysis and reporting are undertaken. - Broad dissemination and knowledge translation to stakeholders is undertaken. A continuous quality improvement process is undertaken in response to reports (with consideration given to quality improvement interventions, and repeat measurement after intervention). - Exceptions: Quality/safety reporting that does not follow the sequence of steps described above can be compromised. Indeed, there are many historical instances of failed or suboptimal quality/safety reporting from administrative data because of skipped steps. (e.g. 1. quality reporting without valid indicators, or appropriate methodologies for risk adjustment, 2. quality reporting without good clinical face validity, 3. quality reporting without a Continuous Quality Improvement (CQI) mind set, etc.). - Examples of sub-use cases (addressing the quality dimensions of effectiveness, efficiency, safety, access) -

reporting on global mortality by facility (e.g. the hospital standardised mortality ratio - HSMR) - reporting on condition-specific mortality - reporting on patient safety indicators - reporting on global or condition-specific length of stay - reporting on readmission rates after hospitalisation - reporting on global or condition-specific costs of care (e.g. cost per hospitalisation) - reporting on waiting times - reporting on small area variability in utilisation

#### **2.23.3.4 Additional information:**

Requirements:

See 'Requirements' section above. There needs to be ongoing development and refinement of quality reporting methodologies (in essence, ongoing research around the development of new administrative data quality indicators and new methodologies for risk adjustment in outcome/quality reporting).

Assumptions:

An underlying assumption in quality or patient safety reporting from administrative data is uniformity of data format and data validity across comparator units (i.e. across provides, hospitals, or jurisdictions). Uniformity in data format and validity is not always present and has been a common reason for criticism of quality or patient safety reports derived from administrative data. In this regard, WHO is promoting ongoing efforts towards standardised coding rules help to facilitate comparative reporting by reducing data variability across comparator units (e.g. rules on factors such as the definition of the 'main condition', numbers of possible codes per record, and the implementation of diagnosis-timing codes). See also the separate use case description for international comparative reporting.

In countries with well developed health information systems, it is quite typical for episodes of hospital-based care to be recorded with varying numbers of ICD codes describing all medical conditions/diagnoses that impacted an episode of care. Furthermore, some systems allow for distinction between diagnoses that were present at time of admission versus diagnoses that arose de novo during the hospital stay. In such systems, the resulting "discharge abstract" can be used for comprehensive and routine morbidity reporting, within which quality and safety concepts are a core component. These include: - adverse events causally linked to medical care - problems in the care process (e.g. error in administration of drug), but without actual adverse event - new diagnoses arising during a hospital stay where causal link to medical care is uncertain

To record and analyse the occurrence of such events, it is crucial for health information systems to have routine morbidity reporting, within which quality and safety concepts are an important component of morbidity coding.

#### **2.23.3.5 Recommendations for use and interpretation of coded data**

These recommendations apply to the use of records in which data were captured and organised as recommended in the previous section: - Select records involving a quality or patient safety event: these are all records with any quality or patient safety harm code. - Summarise types of quality or patient safety harm represented in a set of records: select records with any quality or patient safety harm code. - Summarise the distribution of quality or patient safety Harm codes present in the selected set. - Summarise quality or patient

safety causes of harm in a set of records. - Summarise quality or patient safety mechanisms in a set of records. - Summarise quality or patient safety harm in a set of records.

### **2.23.3.6 ICD use for research purposes**

The morbidity use case for ICD–11 includes a number of situations where the primary goal is to work in an academic research paradigm to extract information from ICD–11 coded data to study burden of disease, clusters of disease, geographic distribution of diseases, and health impacts associated with various diseases. The research paradigm is of course most relevant when it has translational relevance to either health system policy or public health policy, in which case the research paradigm, labelled as such, becomes indistinguishable from applied morbidity analyses conducted for the purpose of health planning. Explicit mention is made here of the widespread use of ICD–11 coded data in a research paradigm, recognising that this is a significant driver for developing a clinically rich and detailed classification system, with novel features and coding rules that enhance the classification’s potential as a research tool.

### **2.23.3.7 ICD use in primary care**

Primary care has been defined as essential front line health care based on practical, scientifically sound, and socially acceptable methods and technology made universally accessible to individuals and families in the community through their full participation and at a cost that the community and the country can afford to maintain. Of relevance to primary care, ICD–11 includes many diagnostic and disease entities that are common reasons for care at the first level of health services. This could be family practitioners, local health nurses, or in other settings also specialists, like Ophthalmologists.

ICD–11 has a simplified version for low diagnostic resource primary care settings. For high diagnostic resource settings, the tabular list for mortality and morbidity statistics contains all elements relevant to primary care and is thus able to be used in high resource environments for primary care, as well as for secondary and tertiary care.

The new version of WONCA’s (World Organization of National Colleges, Academies, and Academic Associations of General Practice/Family Practitioners) International Classification of Primary Care and the ICD–11 will share a common subset of categories.

### **2.23.3.8 ICD use in Casemix groupings**

In casemix grouping systems such as the Diagnosis Related Group (DRG) system, ICD based data are used for reimbursement and/or resource allocation. Such systems are used nationally in systematic fashion.

The assignment of patient cases to groups is based on an algorithm using, in addition to coded diagnosis information, coded procedures, and a number of other variables. The scientific basis of the casemix systems is grounded in health care economics and in the theory of medicine. Since casemix systems are an essential part of administration in countries that use them, smooth transfer to the new revision of the ICD in these systems is essential for the approval and implementation of the new revision.

ICD–11 has been developed to accommodate the different levels of detail that are required in diagnosis-related casemix groupings, in close collaboration with the custodians of the

diverse casemix systems. Joint use in a specific casemix system is driven by the relevant grouper algorithms, and partly also by national legislation.

For matters of international comparability of hospital activity, it is recommended that countries adopt the new WHO definition of main diagnosis and country implementations of ICD–11 apply the new extension codes for the types of diagnoses that are provided with ICD–11.

For international tabulations, in view of the differences in definitions of hospital, episode and in-patient, the resulting diagnoses are listed with the aid of the International Shortlist for Hospital Morbidity Tabulation (refer to section [2.25](#)).

#### 2.23.4 What is coded: Patient conditions

##### 2.23.4.1 Main condition

The definition of main condition relates to the description of an episode of hospital-based care.

The health care practitioner should record and identify as the main condition the one condition that is determined to be the reason for admission, established at the end of the episode of health care. This determination is supported through evaluations and investigations that aim to establish the diagnosis responsible for the admission.

##### 2.23.4.2 Multiple conditions contributing to need for admission

Where an episode of health care includes more than one condition contributing to the need for admission (e.g. congestive heart failure and pneumonia; acute cerebral haemorrhage and hip fracture; multiple injuries - concussion, rib fracture, right femur fracture after MVA; or influenza A and Type 1 diabetic ketoacidosis), the health care practitioner should record and identify the main condition to be the one condition that is deemed to be the most clinically significant reason for admission.

##### 2.23.4.3 Other conditions

In addition to the main condition, the health care practitioner should, whenever possible, also list separately all other conditions or problems dealt with during the episode of health care. Other conditions (also known as additional diagnoses) are defined as those conditions that coexist at the time of admission or develop during the episode of health care and affect the management of the patient. Conditions related to an earlier episode that have no bearing on the current episode should not be recorded as other conditions. It is recommended, where practicable, to carry out multiple-condition coding and analysis to supplement the routine data.

#### 2.23.5 Health care practitioner documentation guidelines for morbidity coding

The health care practitioner responsible for the patient's treatment is also responsible for documenting the patient's health conditions. This information should be organised systematically by using standard recording methods. A properly completed medical record is essential for good patient management. It is also an essential prerequisite to the creation of a valid coded record of patient diagnoses, derived through a coding process from written

information describing a patient's medical condition. When a good written record of patient conditions is available, successful coding of this information in ICD and associated classifications produces a valuable source of epidemiological and other statistical data on morbidity and other health care problems.

The person transforming the information on the stated condition to codes (the 'coder') may be the health care practitioner or a clinical coder who is not responsible for the patient's treatment but is specially trained in use of the classification to assign the code(s). In the latter situation, which is quite common among member countries, the coder depends on the adequacy of clinical documentation relating to the patient's condition(s) provided by health care practitioners in the medical record. The primary importance of clinical documentation by health care practitioners as the starting point for coded health data cannot be overstated and needs to be underlined as being a matter of key importance within countries and internationally – with implications for health information and clinical documentation teaching within health care practitioner training programs.

For clinical and resource allocation purposes, in many instances, the manifestation of a disease (kind and severity, e.g. ulcer grade 3) may be more relevant during a specific treatment episode than the underlying disease (e.g. Diabetes mellitus). For prevention programs at national levels, knowledge about the underlying aetiology may be more important. Quality and safety assessments will require reporting additional detail related to the stay. For comprehensive analysis and use of morbidity data, it is crucial to have a dataset with multiple fields allowing capture of codes relating to all the aspects above.

Morbidity data are increasingly being used in the formulation of health policies and programmes, and in their management, monitoring and evaluation, in epidemiology, in identification of at risk populations, and in clinical research (including studies of disease occurrence in different socioeconomic groups).

In the context of these morbidity coding rules, the term practitioner is used throughout the morbidity rules to mean physician or any qualified health care practitioner who is legally accountable for establishing the patient's diagnosis. This information should be organised systematically by using standard recording methods. A properly completed record is essential for good patient management and is a valuable source of epidemiological and other statistical data on morbidity and other healthcare problems.

The term episode is used for all settings, including hospital admissions. It is acknowledged that the definition may be different in each country, though it is most often considered to be a continuous hospital care period, which begins on the first day of a patient's admission to a health care facility and ends on the day upon which they are separated from that facility through discharge, transfer or death. Some countries consider sequential care periods on different wards within the same hospital to be distinct episodes of care.

The health care practitioner responsible for the patient's treatment is also responsible for documenting the patient's health conditions during an episode of health care. Good clinical documentation is critical to continuity and quality of patient care, communication between members of the treatment team, patient safety and is the legal record of a patient's episode of care. When a sound written record of patient condition(s) is available, successful coding

of this information using the International Classification of Diseases (ICD) and associated classifications produces a valuable source of morbidity data to support:

- Health care planning, management, monitoring and evaluation
- Epidemiology
- Identification of risk populations
- Clinical research
- Reimbursement and health care funding.

The health care practitioner responsible for the patient's treatment should select and document the main condition, as well as any other conditions, for each episode of health care. It is recommended, where practicable, that all conditions are documented to support multiple condition coding and analysis to supplement routine data collection and reporting.

#### **2.23.5.1 Documentation guidelines involving the term 'Multiple'-For Single condition reporting**

In cases involving, for example, 'multiple fractures', 'multiple head injuries' or 'multiple valvular disease', it is acceptable documentation practice to record the diagnoses using the term 'multiple' and then list separately the specific conditions or injuries. For example, Multiple fractures of pelvis: fracture of os pubis, sacrum, ilium.

#### **2.23.5.2 Specificity and detail**

Each diagnostic statement should be as informative as possible in order for the clinical coder to classify the condition to a code that best captures the specific detail provided in the diagnostic statement. Examples of such diagnostic statements include:

- transitional cell carcinoma of trigone of bladder
- acute appendicitis with localised peritonitis
- meningococcal pericarditis
- pregnancy-induced hypertension
- diplopia due to reaction to antihistamine taken as prescribed
- osteoarthritis of hip due to an old hip fracture
- fracture of neck of femur following a fall at home
- full thickness burn of palm of left hand due to grilling accident
- unintentional puncture of the sigmoid colon during colonoscopy

#### **2.23.5.3 Unconfirmed diagnoses**

If no definite diagnosis has been established at the end of an episode of health care, then the health care practitioner should document the information that permits the greatest degree of specificity and knowledge about the reason for admission that has been established at the end of the episode of care. This could be a symptom, abnormal finding or problem. Rather than qualifying a diagnosis as "possible", or "suspected", when a diagnosis has been considered but not established, when applicable, record the symptom, abnormal finding or problem.

#### **2.23.5.4 Documentation of a ruled out condition**

The health care practitioner should document as main condition a “ruled out” condition when the episode of care involves a person who presents some symptoms or evidence of an abnormal condition which requires study, but who, after examination and observation, show no need for further treatment, follow-up or other medical care.

The health care practitioner should not document a ruled out condition as a main condition if some treatment was provided for a symptom or follow-up is required to determine the cause of the sign or symptom. In that instance, the health care practitioner should document the presenting sign or symptom that was treated as the main condition.

##### *Example 1*

Admitted for suspected deep vein thrombosis of leg, which after investigation is ruled out and no follow-up necessary.

Main Condition: Ruled out deep vein thrombosis.

##### *Example 2*

A child is found playing with an empty acetaminophen bottle. The mother is uncertain if there were any tablets in the bottle. The child is brought to the hospital and following investigation, it is determined that the child did not ingest any pills

Main condition: Ruled out unintentional ingestion acetaminophen (paracetamol)

##### *Example 3*

A patient had an elevated PSA and presented for biopsy of the prostate. Biopsy revealed no evidence of malignancy. No further follow-up planned for the patient.

Main condition: Ruled out prostate malignancy

See Section [2.23.17 Coding a “ruled out” condition](#) for more detail.

#### **2.23.5.5 Contact with health services for reasons other than illness**

Episodes of health care or contact with health services are not restricted to identification, treatment or investigation of current illness or injury. Episodes may also occur when someone who may not currently be sick requires or receives limited care or services. In this case the health care practitioner should document the details of the relevant circumstances as the ‘main condition’.

Examples include:



- monitoring of previously treated conditions
- immunisation
- contraceptive management, antenatal and postpartum care
- surveillance of persons at risk because of personal or family history
- examinations of healthy persons, e.g. for insurance or occupational reasons
- seeking of health-related advice
- requests for advice by persons with social problems
- consultation on behalf of a third party
- organ or tissue donors
- circumstances related to drugs, procedures, or devices without documented injury or harm to patient

Chapter 24 'Factors influencing health status and contact with health services' provides a broad range of categories for classifying these circumstances. Reference to this chapter will give an indication of the detail required to permit coding to the most relevant category.

#### 2.23.5.6 Conditions due to external causes

When a condition such as an injury, poisoning or other effect of an external causes is recorded, it is important to document fully both the nature of the condition and the circumstances that gave rise to it. For example:

- 'fracture of neck of femur caused by fall due to slipping on pavement'
- 'cerebral contusion caused when patient lost control of car, which hit a tree'
- 'unintentional poisoning, patient drank disinfectant in mistake for soft drink'
- 'severe hypothermia, patient fell in her garden in cold weather'

See also Section [2.23.20.2 Causation in the context of quality and safety](#).

#### 2.23.5.7 Documentation of sequelae

Where an episode of care is for the treatment or investigation of a residual condition (sequela) of a disease that is itself no longer present, the health care practitioner should document the residual condition (sequela) and its origin, together with a clear indication that the original disease is no longer present. For example:

- 'deflected nasal septum– fracture of nose in childhood'
- 'contracture of Achilles tendon – late effect of injury to tendon'
- 'infertility due to tubal occlusion from old tuberculosis'.

Where multiple sequelae are present and treatment or investigation is not directed predominantly at one of them, a documented statement such as 'sequelae of cerebrovascular accident' or 'sequelae of multiple fractures' is acceptable.

#### 2.23.6 Coder guidelines for selecting 'main condition' and 'other conditions' for coding purposes

The main condition and other condition(s) relevant to an episode of health care should have been identified and recorded by the responsible health care practitioner, and coding will

therefore usually be straightforward. The main condition recorded should be accepted for coding and reporting unless it is obvious that the health care practitioner did not follow the guidelines for recording diagnostic information for morbidity data analysis. Whenever possible, a record with an obviously inconsistent or incorrectly recorded main condition should be returned to the health care practitioner for clarification.

If clarification of potentially erroneous documentation is not possible, one of the following rules can be applied by the clinical coder and the main condition reselected for reporting purposes. The rules are for use when it is unclear which recorded condition should be selected as the main condition for reporting purposes.

- MB1 Several conditions recorded as 'main condition'; or
- MB2 Condition recorded as 'main condition' is presenting symptom of diagnosed, treated condition; or
- MB3 Signs and symptoms recorded as 'main condition' with alternative conditions recorded as the cause

### **Coder rules for reselection of main condition**

#### **2.23.6.1 MB1 - Several conditions recorded as 'main condition'**

If several different conditions (that cannot be classified to a single stem code) are recorded as the 'main condition', and other details on the record point to one of them being the 'main condition' (one condition determined to be the reason for admission established at the end of the episode of care), select that condition; otherwise, select the condition first recorded.

If there is the desire to also report other discharge diagnosis types i.e. main resource condition or initial reason for encounter or admission, then the applicable extension code(s) from Chapter X 'Extension codes', should be assigned to indicate the different types of discharge diagnosis types that are reported.

#### **Example 1:**

A patient was admitted with complaints of fever, chills, severe headache and stiff neck. Following investigation, a diagnosis of staphylococcal meningitis was confirmed. While in hospital the patient developed pneumonia.

Main condition: Staphylococcal meningitis. Pneumonia

Two conditions have been recorded as the main condition and querying the health care practitioner is not possible. The details in the example point to staphylococcal meningitis as the one condition being the reason for admission established at the end of the episode of care, therefore the coder should code staphylococcal meningitis as the 'main condition'. Pneumonia is coded as an 'other condition'. It meets the definition of an 'other condition' as it is a diagnosis that arose during the episode of care.

#### **Example 2:**

A patient who has a history of COPD was admitted for a biopsy of the prostate. Patient was evaluated for COPD. Biopsy was performed and the final diagnosis from pathology results was benign prostatic hypertrophy.

Main condition: Chronic obstructive pulmonary disease (COPD). Hypertrophy of prostate.

Two conditions have been recorded as the main condition and querying the health care practitioner is not possible. The details in the example point to benign prostatic hypertrophy as the condition being the reason for admission established at the end of the episode of care; therefore, the coder should code hypertrophy of prostate as the 'main condition'. COPD is coded as an 'other condition' as the physician documented it as co-existing at the time of admission and affecting the management of the patient.

**Example 3:**

A patient presents to hospital at 35 weeks gestation with spontaneous premature rupture of membranes. She is not having any contractions. Examination reveals the baby is in breech presentation; therefore, delivery by caesarean section is recommended. Mother delivers healthy preterm infant by caesarean section.

Main condition: Premature rupture of membranes. Breech presentation.

Procedure: Delivery by caesarean section

Two conditions have been recorded as the main condition and querying the health care practitioner is not possible. The details in the example point to premature rupture of membranes as the condition being the reason for admission established at the end of the episode of care. Therefore, the coder should code premature rupture of membranes as the 'main condition' and breech presentation and preterm delivery as 'other condition'.

**Example 4:**

A patient is admitted to the hospital with pneumonia and congestive heart failure.

Main condition: Pneumonia and Congestive Heart Failure.

Two conditions have been recorded as the main condition and querying the health care practitioner is not possible. There are no other details on the record to point to one of the conditions as being the main condition, therefore, in this instance, the coder should code the first listed condition as the main condition. Pneumonia is coded as the 'main condition' and congestive heart failure is coded as an 'other condition'.

**2.23.6.2 MB2 - Condition recorded as 'main condition' is presenting symptom of diagnosed, treated condition**

If a symptom or sign (usually classifiable to Chapter 21 Symptoms, signs or clinical findings, not elsewhere classified), or a problem classifiable to Chapter 24 Factors influencing health status or contact with health services, is recorded as the 'main condition', and this is obviously the presenting sign, symptom or problem of a diagnosed condition recorded elsewhere and care was given for the latter, reselect the diagnosed condition as the 'main condition'.

**Example 1:**

The patient presents to hospital with complaint of haematuria. Investigations reveal a papilloma in the posterior wall of the bladder as the cause of the haematuria. The papilloma was excised by diathermy.

Main condition: Haematuria

Other conditions: Papilloma of posterior wall of bladder

Haematuria (symptom) is recorded as the main condition; however, it was determined to be caused by the papilloma of the bladder (diagnosed and treated condition). Therefore, the coder should reselect and code papilloma of posterior wall of bladder as the 'main condition'.

**Example 2:**

The patient presents to hospital with abdominal pain. Investigations reveal acute appendicitis and the patient undergoes an appendectomy.

Main condition: Abdominal pain

Other conditions: Acute appendicitis

The symptom 'abdominal pain' was recorded as the main condition; however, it was determined to be caused by appendicitis. Therefore, the coder should reselect and code acute appendicitis as the 'main condition'.

**Example 3:**

A patient with known COPD is admitted to hospital with acute respiratory failure which after investigation is found to be caused by an acute exacerbation of COPD.

Main condition: Acute respiratory failure

Other condition: Acute exacerbation of COPD

The symptom "acute respiratory failure" was recorded as the main condition; however, it was determined to be caused by exacerbation of COPD with acute exacerbation. Therefore, the coder should reselect and code the COPD as the 'main condition'

**2.23.6.3 MB3 - Signs and symptoms recorded as 'main condition' with alternative conditions recorded as the cause**

Where a symptom or sign is recorded as the 'main condition' with documentation that it may be due to either one condition or another, select the symptom as the 'main condition'.

**Example 1:**

Main condition: Headache due to tension or acute sinusitis

The symptom 'headache' is recorded as the main condition with two possible causes; therefore, the coder should code headache as the 'main condition'.

### 2.23.7 Coding using postcoordination in morbidity

A significant new feature in ICD–11 is an embedded functionality for postcoordinating detail related to diagnostic concepts see Section [2.10.2 Combining stem codes and extension codes, and how to order these in a complex code cluster](#), and Section [2.10.1 Adding detail – postcoordination and cluster coding with multiple stem codes and extension codes](#).

The postcoordinated coding of diagnostic concepts described by the health care practitioner is shown in the following examples:

#### Example 1

A patient is admitted to the hospital for laser treatment of their diabetic retinopathy due to Type 2 diabetes mellitus. During the admission the patient’s medication for arterial hypertension required adjustment on a number of occasions before discharge. Code as main condition the diabetic retinopathy, unspecified postcoordinated with the stem code type 2 diabetes mellitus ([9B71.OZ/5A11](#)). Code the other condition, essential hypertension ([BA00.Z](#)).

For morbidity coding, the order of the codes in the first cluster in Example 1 has the diabetic retinopathy ordered first as it is the diabetic retinopathy that meets the definition of main condition followed by the causing condition Type 2 diabetes. (Note: The classification instructs to code also the type of diabetes.)

Where an established causal relationship is not documented or cannot be inferred, the two stem codes cannot be part of the same cluster.

#### Example 2

Patient admitted for right cataract extraction. The patient also has Type 2 diabetes mellitus and was reviewed by the endocrinologist and dietitian for their long-term diet and insulin plan. Code the main condition as Cataract, unspecified, right ([9B10&XK9K](#)). Code the other condition as Type 2 diabetes mellitus ([5A11](#)).

Example 2 demonstrates postcoordination where a causal relationship between the cataract and the Type 2 diabetes has not been documented and cannot be inferred; therefore, the two stem codes for each condition are reported separately. Postcoordination for the laterality for the cataract was applied here.

#### 2.23.7.1 Coder rule for use of extension codes

##### *Adding detail to Stem codes using Extension Codes*

Type 2 extension codes (a new section of codes in ICD–11) provide distinct codes that serve as concept modifying flags for marking how a diagnosis is to be used and/or interpreted. Examples of these extension code modifiers include:

- Discharge diagnosis types (main condition; main resource condition; initial reason for encounter or admission);
- Diagnosis certainty (Provisional diagnosis; Differential diagnosis)
- Diagnosis Timing (Present on admission; Developed after admission; Uncertain timing of onset relative to admission)

For more detail about the use of all available extension codes, see Section [2.9Extension codes](#).

## Example 1

A patient is admitted to hospital with chest pain and after investigation is diagnosed with a myocardial infarction and then develops a stroke that leads to a one-month hospitalisation. Myocardial infarction is coded as the main condition because it was the reason for admission established at the end of the stay. The stroke is coded separately and can be postcoordinated with a diagnosis-type extension code flag indicating that the stroke diagnosis arose after admission.

Such a system with diagnosis flags meets the objectives of countries that want a reason-for-admission coding rule, while also meeting the objectives of countries that want to be able to make inferences regarding complications of care and resource consumption (which are of relevance to casemix systems and patient safety and quality assessments).

### 2.23.8 Coding from health care practitioner documentation of ‘causal relationships’

Sometimes conditions that have a causal relationship are clearly documented by the health care practitioner using terms such as ‘due to’, ‘caused by’, or ‘arising from’. These connecting terms indicate the health care practitioner has made a causal link between, for example, condition A due to condition B. However, sometimes conditions are documented with connecting terms that are ambiguous for the coder such as ‘with’, ‘after’, ‘in’, and ‘following’. When ambiguous terms are documented, and it is not clear whether the health care practitioner means a causal relationship or not, the clinical coder should code each condition separately and not link the conditions in a cluster.

The clustering (postcoordination) is a particularly notable new feature in ICD-11 that has permitted the introduction of powerful new clinical coding mechanisms for capturing clinical information in dimensions such as:

- quality and safety coding for health care related injury and harms (see three-part model described in Section [2.23.20.1](#))
- injury and the external cause of injury
- the addition of clinical detail using extension codes
- the specification of diagnosis type and diagnosis timing using extension codes
- the comprehensive description of late effects (sequelae) arising from prior conditions (See Section [2.21.6](#))
- the description of inter related stem code diagnoses where there is a clear causal relationship between them

For more information on causal inference in the context of quality and safety, refer to Section [2.23.20.2 Causation in the context of quality and safety](#).

### 2.23.9 Coding of suspected conditions or symptoms, abnormal findings and non-illness situations

If the episode of health care was for an inpatient, the coder should be cautious about classifying the main condition to Chapters 21 Symptoms, signs or clinical findings, not elsewhere classified and Chapter 24 Factors influencing health status or contact with health services. If a more specific diagnosis has not been made by the end of the inpatient stay, or if there was truly no codable current illness or injury, then codes from the above chapters

are permissible. The categories can be used in the normal way for other episodes of contact with health services.

If, after an episode of health care, the main condition is recorded as ‘suspected’, ‘questionable’, etc., and there is no further information or clarification, the suspected diagnosis must be coded as if established.

### Example 1

Main condition: Suspected acute cholecystitis If there is no further information available that indicates that a definitive diagnosis was reached, code to acute cholecystitis, unspecified ([DC12.0Z](#)) as ‘main condition’.

### Example 2

Main condition: Severe epistaxis. Patient in hospital one day. No procedures or investigations reported. Code to epistaxis ([MD20](#)). Although epistaxis is a sign/symptom, it is acceptable since the patient was obviously admitted to deal with the immediate emergency only.

## 2.23.10 Coding using combination categories

The ICD provides certain categories where two conditions or a condition and an associated secondary process can be represented by a single code (i.e. precoordinated concept). Such combination categories should be used where appropriate information is recorded.

### Example 1:

Main condition: Chronic Kidney Disease (CKD), Stage 4 secondary to hypertensive renal disease Other condition: Essential hypertension Code to Chronic Kidney disease, stage 4 ([GB61.4](#)) and add the Hypertensive renal disease ([BA02](#)) in a cluster. Main condition Cluster: [GB61.4/BA02](#) Other condition: [BA00](#) *Essential hypertension*

### Example 2:

Main condition: Glaucoma secondary to eye inflammation Code to [9C61.24](#) *Glaucoma due to eye inflammation*. This is a precoordinated code in ICD-11.

### Example 3:

Main condition: Diabetic cataract. Type 1 diabetes mellitus Other conditions: Hypertension Code Diabetic cataract ([9B10.21](#)) and ‘code also’ the type of diabetes mellitus ([5A10](#)). Postcoordinate the stem code for diabetic cataract and stem code for Type 1 diabetes mellitus. Main condition Cluster: [9B10.21/5A10](#). The hypertension is not linked to the cataract or diabetes, so it is not part of the cluster. It is coded as an ‘other condition’.

### Example 4:

Main condition: Rheumatoid arthritis Other conditions: Hypertension, Type 2 diabetes mellitus, Cataract Code to Rheumatoid arthritis, serology unspecified ([FA20.Z](#)) as ‘main condition’. Code the other conditions (hypertension ([BA00.Z](#)), type 2 diabetes mellitus ([5A11](#)), cataract ([9B10.Z](#))) separately. If any optional extension codes are added to any one of the conditions, then a cluster(s) is created as applicable because extension codes cannot be reported alone. Note that in this example, the linkage (through clustering) of cataract with diabetes must not be made as the cataract has not been documented as a diabetic cataract. In this case there is no combination indicating clustering should be used.

Main condition: [FA20.Z](#) Other condition: [BA00.Z](#) Other condition: [5A11](#) Other condition: [9B10.Z](#)

### 2.23.11 Coding using external causes of morbidity

For injuries and other conditions due to external causes, both the nature of the condition and the circumstances of the external cause should be coded. The preferred 'main condition' code should be that describing the nature of the condition. This will often, but not always, be classifiable to Chapter 22 Injury, poisoning or certain other consequences of external causes. The code from Chapter 23 External causes of morbidity or mortality indicating the external cause is assigned as an additional code and postcoordinated with the nature of the condition as it may be regarded as a modifier. See also Section [2.23.20.1](#).

#### Example 1:

Main condition: Fracture of neck of femur caused by fall Other conditions: Contusions to elbow and upper arm The health care practitioner has identified the fracture as the main condition and since there is no other information to make the coder question the main condition recorded, the coder should code fracture of neck of femur, unspecified ([NC72.2Z](#)) as the 'main condition'. The external cause code for unintentional fall from unspecified height ([PA6Z](#)) is used as an additional code linked to the fracture code through postcoordination. The contusion of elbow ([NC30.1](#)) and upper arm ([NC10.1](#)) are coded as another condition cluster and the external cause code for unintentional fall ([PA6Z](#)) is linked to the contusion code through postcoordination.

Main condition cluster: [NC72.2Z/PA6Z](#) Other condition cluster: [NC30/NC30.1/NC10.1](#)

#### Example 2:

Main condition: Hip fracture from fall Other condition: Severe hypothermia resulting from exposure to the cold weather Code to [NC72.2Z](#) *Fracture of neck of femur, unspecified* as 'main condition' and postcoordinate the external cause code for [PA6Z](#) *Unintentional fall from unspecified height*. Code as "other condition" hypothermia ([NF02](#)) and postcoordinate the external cause code [PB16](#). Main condition cluster: [NC72.2Z/PA6Z](#) Other condition cluster: [NF02/PB16](#)

#### Example 3:

Main condition: Diplopia due to reaction to antihistamine taken as prescribed Code to diplopia [9D46](#) and postcoordinate the external cause code for [PL00](#) *Drugs, medicaments or biological substances associated with injury or harm in therapeutic use* and [PL13.2](#) *Drug-related injury or harm in the context of correct administration or dosage, as mode of injury or harm*. An optional extension code may be added to identify the specific drug was an antihistamine XM4J58.

Main condition cluster: [9D46/PL00&XM4J58/PL13.2](#)

### 2.23.12 Coding of acute and chronic conditions recorded as main condition

Where the main condition is recorded as being both acute (or subacute) and chronic, and the ICD provides separate categories or subcategories for each, but not for the combination, the code for the acute condition should be reported as the main condition (the condition determined to be the reason for admission established at the end of the episode of care). When an appropriate combination code is provided for both the acute and chronic condition, assign the combination code as the main condition.

#### Example 1:

Main condition: Acute on chronic cholecystitis Code [DC12.00](#) *Acute on chronic cholecystitis* as the 'main condition'. This is an example of combination code for both the acute and chronic condition in ICD-11.

#### Example 2:



Main condition: Acute exacerbation of chronic obstructive pulmonary disease Code to [CA22.0](#) *Chronic obstructive pulmonary disease with acute exacerbation, unspecified* as the ‘main condition’ since the ICD provides an appropriate single precoordinated code for the combination.

### 2.23.13 Coding of injuries or harm arising from surgical or medical care

Refer to Section [2.23.20.1 Overview of code-set in ICD–11 for quality and patient safety](#).

### 2.23.14 Coding of adverse events and circumstances in health care that do not cause actual injury or harm

Refer to Section [2.23.20.1 Overview of code-set in ICD–11 for quality and patient safety](#).

### 2.23.15 Coding of chronic postprocedural conditions

Most body-system chapters also contain categories for permanent (chronic) conditions that occur either as a consequence of specific procedures and techniques or as a result of the removal of an organ, e.g. postmastectomy lymphoedema syndrome, post-irradiation hypothyroidism. Immediate or acute conditions that occur as a consequence of a procedure may require coding with the 3-part quality and safety model. See also Section [2.23.20.1 Overview of code-set in ICD–11 for quality and patient safety](#). The categories of postprocedural conditions do not have residual codes (i.e. other and unspecified). This is intentional so as to prevent users inadvertently classifying conditions to these categories that should, in fact, be classified elsewhere.

### 2.23.16 Coding ‘History of’ and ‘Family history of’

Chapter 24 ‘Factors influencing health status or contact with health services’ of the classification includes a number of codes that describe both a personal history of various conditions, and a family history of various conditions. The classification of this documented concept may be coded in one of two ways.

Option 1: Assign the applicable stem code from Chapter 24 ‘history of’ (or ‘family history of’) by itself.

Option 2: Assign the applicable stem code from Chapter 24 clustered with a code from another chapter to add specificity as to what the previous ‘disease’ was. The order of stem codes in the cluster is always the ‘history of’ stem code first, followed by any other codes that may be added for detail.

#### **Example 1:**

A patient has history of sigmoid colon cancer that was curatively resected. Code: [QC40.0](#) Personal history of malignant neoplasm of digestive organs/[2B90.3Z](#) Malignant neoplasm of sigmoid colon, unspecified

In example 1, it is acceptable to code only [QC40.0](#) as the code simply captures the notion that the patient has a personal history of cancer of the digestive organs. However, the documented clinical concept (history sigmoid colon cancer) is fully described through use of the clustering mechanism and linking of stem codes [QC40.0/2B90.3Z](#).

#### **Example 2:**

A patient has a family history of macular degeneration. Code: [QC66](#) Family history of eye or ear disorders/[9B78.3Z](#) Degeneration of macula or posterior pole, unspecified

### 2.23.17 Coding a “ruled out” condition

Many health care encounters are undertaken to evaluate patients for suspected conditions, to then determine after investigations that the patient does not have the condition in question. In medical documentation, such scenarios often use the term “ruled out”. It is essential for health information systems to have an ability to report on such encounters.

ICD-11 includes a number of codes that can be used to describe encounters where a suspected condition has been “ruled out”. These appear in Chapter 24 as children of [QA02](#) *Medical observation or evaluation for suspected diseases or conditions, ruled out*. Some of these codes specify the suspected condition in question:

- Observation for suspected malignant neoplasm, ruled out
- Observation for suspected tuberculosis, ruled out
- Observation for suspected allergy or hypersensitivity, ruled out

In many other common scenarios, there is no code for a specified suspected condition, in which case, [QA02.Y](#) *Medical observation or evaluation for other suspected diseases or conditions, ruled out*, is used. In such cases, postcoordination can be used to specify the suspected condition that was ruled out. The classification of the documented concept “ruled out” may be coded in one of two ways. Option 1: Assign the applicable code from [QA02](#) *Medical observation or evaluation for suspected diseases or conditions, ruled out*, by itself. Option 2: Assign the applicable code from [QA02](#) *Medical observation or evaluation for suspected diseases or conditions, ruled out*, clustered with a code from another chapter to add specificity as to what was the suspected disease that was ruled out. The order of stem codes in the cluster is always the [QA02](#) stem code first.

#### Example 1

Admitted for suspected deep vein thrombosis of leg, which after investigation is ruled out and no follow-up necessary. Main Condition: Ruled out deep vein thrombosis. Code main condition cluster: [QA02.Y/BD71.4](#)

Explanation: [QA02.Y](#) indicates that an other specified condition was ruled out and postcoordination allows specification of what the suspected condition was (deep vein thrombosis leg).

#### Example 2

A child is found playing with an empty acetaminophen bottle. The mother is uncertain if there were any tablets in the bottle. The child is brought to the hospital and following investigation, it is determined that the child did not ingest any pills. Main condition: Ruled out unintentional ingestion of acetaminophen. Code: [QA02.5](#) *Observation for suspected toxic effect from ingested substance, ruled out*. Explanation: In this example, [QA02.5](#) specifies the condition that was ruled out.

### 2.23.18 Coding of conditions documented as sequela (late effect)

‘Sequelae’ include residual effects of diseases or disorders, injuries or poisonings specified as such, or as late effect of, arrested, cured, healed, inactive, old or quiescent condition unless there is evidence of active disease. Conditions documented as a sequela (late effect) will typically be classified using postcoordination depending on the case.

The cluster should contain:

- first, a stem code identifying the specific manifestation (i.e. nature of the effect), and
- second, a stem code designating ‘late effect of’ (either a code from the body system chapters or a code from Chapter 24 Factors influencing health status or contact with health services)
- third, if required, a stem code representing the prior condition causing the sequelae

Note: Coding of sequelae of an injury with all detail will require four codes in the cluster, the fourth code being the external cause code.

#### Example 1:

Joint contracture present as a late effect of a prior burn. Code cluster: [FA34.3](#) Contracture of joint [QC50](#) Late effect of prior health problem, not elsewhere classified [NE11](#) Burn of unspecified body region/[PB1Z](#) Unintentional exposure to unspecified thermal mechanism

#### Example 2:

Hemiplegia present as a late effect of old cerebral ischemic stroke. Code cluster: [MB53.Z](#) Hemiplegia, unspecified/[8B25.0](#) Late effects of cerebral ischemic stroke Note: In Example 2, the concept of late effect and underlying cause is already precoordinated in the stem code [8B25.0](#).

### 2.23.19 Standards and coding instructions for injury events

The WHO definition of an ‘injury’ is: ‘acute exposure to physical agents such as mechanical energy, heat, electricity, chemicals, and ionizing radiation interacting with the body in amounts or at rates that exceed the threshold of human tolerance. In some cases, (for example, drowning and frostbite), injuries result from the sudden lack of essential agents such as oxygen or heat’. Injuries may be categorised in a number of ways. However, for most analytical purposes and for identifying intervention opportunities, it is especially useful to categorise injuries according to whether or not they were deliberately inflicted and by whom. Commonly used categories are:

- unintentional (i.e. accidental)
- intentional (i.e. deliberate)
- interpersonal (e.g. assault and homicide)
- self-harm (e.g. abuse of drugs and alcohol, self-mutilation, suicide)
- legal intervention (e.g. action by police or other law enforcement personnel)
- war, civil insurrection and disturbances (e.g. demonstrations and riots)
- undetermined intent

Regarding the collection of events that cause injuries, a set of definitions apply. See section ‘Definition related to transport injury events’ below.

#### 2.23.19.1 Descriptions related to transport injury events

- (a) A ‘transport injury event’ is any unintentional injury involving a device designed primarily for, or being used at the time primarily for, conveying persons or goods from one place to another.
- (b) A public highway (trafficway) or street is the entire width between property lines (or other boundary lines). It includes the space of open public land used for purposes of moving persons or property from one place to another. A roadway is that part of the public highway designed, improved and customarily used for vehicular traffic.

- (c) A road traffic injury event is any unintentional injury occurring on the public highway [i.e. originating on, terminating on, or involving a vehicle partially on the highway]. An unintentional injury involving a vehicle is assumed to have occurred on the public highway unless another place is specified, except in the case of unintentional injury involving only off-road motor vehicles, which are classified as unintentional injury not caused by traffic unless the contrary is stated.
- (d) An off-road, nontraffic road injury event is any unintentional injury that occurs entirely in any place other than a public highway.
- (e) A pedestrian is any unintentionally injured person involved who was not at the time of the event riding in or on a motor vehicle, railway train, streetcar or bus or animal-drawn or other vehicle, or on a pedal cycle or animal.
  - Pedestrians include those:
    - changing a tire of vehicle
    - making an adjustment to the motor of a vehicle
    - on or in items which assist with pedestrian conveyance, including:
      - baby carriage
      - ice-skates
      - perambulator
      - push-chair
      - roller-skates
      - scooter
      - skateboard
      - skis
      - sled
      - wheelchair (powered)
- (f) A driver is an occupant of a transport vehicle who is operating or intending to operate it.
- (g) A passenger is any occupant of a transport vehicle other than the driver.
 

Excludes: person traveling on outside of vehicle - see definition (h) below
- (h) A person 'traveling on' a transport vehicle includes any person being transported by a vehicle but not occupying the space normally reserved for the driver or passengers, or the space intended for the transport of property.
  - 'Traveling on' includes:
    - bodywork
    - bumper [fender]
    - hanging on outside
    - roof (rack)
    - running-board
    - step
- (i) A pedal cycle is any land transport vehicle operated solely by pedals.

Includes: bicycle tricycle Excludes: motorised bicycle - see definition (k)

- (j) A pedal cyclist is any person riding on a pedal cycle or in a sidecar or trailer attached to such a vehicle.
- (k) A motorcycle is a two-wheeled motor vehicle with one or two riding saddles and sometimes with a third wheel for the support of a sidecar. The sidecar is considered part of the motorcycle.
- Includes:
    - moped motor scooter motorcycle:
      - NOS
      - combination
      - with sidecar
      - motorised bicycle
      - speed-limited motor-driven cycle
  - Excludes: motor-driven tricycle - see definition (m)
- (l) A motorcycle rider is any person riding on a motorcycle or in a sidecar or trailer attached to such a vehicle.
- (m) A three-wheeled motor vehicle is a motorised tricycle designed primarily for on-road use.
- Includes:
    - motor-driven tricycle
    - motorised rickshaw
    - three-wheeled motor car
  - Excludes:
    - motorcycle with sidecar - see definition (k)
    - special all-terrain vehicle - see definition (x)
- (n) A car (automobile) is a light transport vehicle with four or more wheels designed primarily for carrying up to 10 persons. A trailer or caravan being towed by a car is considered a part of the car.

Includes: minibus

- (o) A motor vehicle or vehicle may refer to various transport vehicles. The local usage of the terms should be established to determine the appropriate code. If the terms are used ambiguously, use the code for 'unspecified'. A trailer or caravan being towed by a vehicle is considered a part of the vehicle.
- (p) A light goods vehicle (pick-up truck or van) is a motor vehicle with four or more wheels designed primarily for carrying property on roads, weighing less than the local limit for classification as a heavy goods vehicle (usually less than 3500 kg), and not requiring a special driver's licence. A trailer or caravan being towed by a light goods vehicle is considered a part of the vehicle.

- (q) A heavy goods vehicle is a motor vehicle designed primarily for carrying property on roads, meeting local criteria for classification as a heavy goods vehicle in terms of curbside weight (usually above 3500 kg), and requiring a special driver's licence.
- (r) A bus is a motor vehicle designed or adapted primarily for carrying more than 10 persons and requiring a special driver's licence to operate.
- (s) A railway train or railway vehicle is any device, with or without cars coupled to it, designed for traffic on a railway.
  - Includes:
    - interurban:
      - electric car
      - street car (operated chiefly on its own right-of-way, not open to other traffic) railway train, any power [diesel] [electric] [steam]
      - funicular
      - monorail or two-rail subterranean or elevated other vehicle designed to run on a railway track
  - Excludes:
    - interurban electric cars (streetcars) specified to be operating on a right-of-way that forms part of the public street or highway - see definition (t)
- (t) A streetcar is a vehicle designed and used primarily for transporting persons within a municipality, running on rails, usually subject to normal traffic control signals, and operated principally on a right-of-way that forms part of the roadway. A trailer being towed by a streetcar is considered a part of the streetcar.
  - Includes:
    - interurban electric car or streetcar, when specified to be operating on a street or public highway
    - tram (car)
    - trolley (car)
- (u) A special vehicle mainly used on industrial premises is a motor vehicle designed primarily for use within the buildings and premises of industrial or commercial establishments.
  - Includes:
    - battery-powered:

- airport passenger vehicle
  - truck (baggage)(mail)
  - coal-car in mine
  - forklift (truck)
  - logging car
  - self-propelled truck, industrial
  - station baggage truck (powered)
  - tram, truck or tub (powered) in mine or quarry
- (v) A special vehicle mainly used in agriculture is a motor vehicle designed specifically for use in farming and agriculture (horticulture), for example to work the land, tend and harvest crops and transport materials on the farm.
- Includes:
    - combine harvester
    - self-propelled farm machinery
    - tractor (and trailer)
- (w) A special construction vehicle is a motor vehicle designed specifically for use in the construction (and demolition) of roads, buildings and other structures.
- Includes:
    - bulldozer
    - digger
    - dumper truck
    - earth-leveller
    - mechanical shovel
    - road-roller
- (x) A special all-terrain vehicle is a motor vehicle of special design to enable it to negotiate rough or soft terrain or snow. Examples of special design are high construction, special wheels and tyres, tracks, and support on a cushion of air.
- Includes: - hovercraft on land or swamp - snowmobile
  - Excludes: hovercraft on open water - see definition (y)
- (y) A watercraft is any device for transporting passengers or goods on water.

Includes: hovercraft NOS

- (z) An aircraft is any device for transporting passengers or goods in the air.

### **2.23.19.2 Classification and coding instructions for unintentional injury caused by transport**

Transport injury events are counted for official statistics where they are unintentional.

1. If an event is unspecified as to whether it was a traffic or a nontraffic-injury event, the following definitions should be used:
  - a) Classify as a traffic injury event occurs when the event is classifiable to the traffic categories.

- b) Classify as a nontraffic injury event occurs when the event is classifiable to nontraffic categories.

For these categories the victim is either a pedestrian, or an occupant of a vehicle designed primarily for off-road use.

2. When unintentional injury involving more than one kind of transport are reported, the following order of precedence should be used:
  - aircraft and spacecraft
  - watercraft
  - other modes of transport
3. Where transport injury event descriptions do not specify the victim as being a vehicle occupant and the victim is described as crushed, dragged, hit, injured, killed, knocked down, run over by any vehicle including:
  - animal being ridden
  - animal-drawn vehicle
  - bicycle
  - bulldozer
  - bus
  - car
  - motorcycle
  - motorised tricycle
  - pick-up (truck)
  - recreational vehicle
  - streetcar
  - tractor
  - train
  - tram
  - truck
  - van

Classify the victim as a pedestrian.

4. Where transport injury event descriptions do not indicate the victim's role, classify the victim as an occupant or rider of the vehicle if there is mention of vehicles such as:



- airplane
- bicycle
- boat
- bulldozer
- bus
- car
- motorcycle
- motorised tricycle
- pick-up (truck)
- recreational vehicle
- spacecraft
- tractor
- train
- tram
- truck
- van
- watercraft
- accident
- collision
- crash
- wreck
- NOS

Classify the victim as an occupant or rider of the vehicle mentioned. If more than one vehicle is mentioned, do not make any assumption as to which vehicle was occupied by the victim unless the vehicles are the same. Instead, code to the appropriate categories, taking into account the order of precedence given in note 2 above.

5. Where a transport injury event, such as:

- vehicle (motor) (non-motor): – going out of control (due to):
- burst tyre (blowout)
- driver falling asleep
- driver inattention
- excessive speed
- failure of mechanical part resulted in a subsequent collision

Classify the unintentional injury as a collision. If an unintentional injury other than a collision resulted, classify it as a noncollision injury according to the vehicle type involved.

6. Where an unintentional injury involving a vehicle in motion, such as:
- unintentional poisoning from exhaust gas generated by breakage of any part or explosion of any part of
  - fall, jump or being unintentionally pushed from
  - fire starting in
  - hit by object thrown into or onto
  - injured by being thrown against some part of, or object in
  - injury from moving part of
  - object falling in or on vehicle in motion
  - resulted in a subsequent collision

Classify as a collision.

If an accident other than a collision resulted, classify it as a noncollision injury according to the vehicle type involved.

Unintentional injury due to land transport described as:

- collision (due to loss of control) (on highway) between vehicle and:
  - abutment (bridge)(overpass)
  - fallen stone
  - guard rail or boundary fence
  - inter-highway divider
  - landslide (not moving)
  - object thrown in front of motor vehicle
  - safety island
  - tree
  - traffic sign or marker (temporary)
  - utility pole
  - wall of cut made for road
  - other object, fixed, movable or moving
- overturning (without collision)
- collision with animal (herded)(unattended)
- collision with animal-drawn vehicle or animal being ridden are included.

#### 2.23.20 Conceptual model for quality and patient safety

Exposure to health care events sometimes has unintended and undesired consequences. Health care, the people to whom it is provided, and the complications that can arise in the course of care are highly diverse and complex. Representing them comprehensively in an information system is challenging and is presently beyond the bounds of practicality for routine administrative information systems of the types that are intended to make use of the ICD. The conceptual model has three components:

1. **Harm** to the patient: What was the main consequence for the patient's health?
2. **Cause** or source of harm: What caused the harm?
3. **Mode** or mechanism: In what way? How did the source of harm actually produce harm?

### 2.23.20.1 Overview of code-set in ICD-11 for quality and patient safety

A key feature of the quality and patient safety code-set in ICD-11 is that a cluster of codes is required to represent a case. Use of the term 'cluster' is novel in ICD-11 and so is the extent and formalisation of the requirement for postcoordination. The quality and safety use case of the ICD is based on the availability of large numbers of methodological tools that are originally based on ICD-10. Specific examples include the Charlson and Elixhauser co-morbidity indices, AHRQ (Agency for Healthcare Research and Quality) Patient Safety Indicators, the Hospital Standardised Mortality Ratio, and various other administrative data quality indicators. WHO recommendations on coding rules for hospital separation episodes are designed to improve comparability of records across hospitals and jurisdictions. Specific examples of coding rules include:

- rules for specifying the main condition,
- numbers of codes per record,
- code clustering mechanisms, and
- use of a status display system that distinguishes diagnoses arising during a hospital stay from those present at admission.

Quality and patient safety reporting is often focused not only on diagnostic information available in the International Classification of Diseases, but also on procedure information, that is currently coded in various country-specific procedure coding systems. The harmonisation of ontological concepts in international procedure coding systems will be important going forward. The available medical and surgical complication codes of ICD-11 are in line with current knowledge in the domain of safety and adverse events.

There are three parts to the Quality and Safety model. The first component, quality and patient safety **Harm**, is usually represented by a standard ICD-11 diagnosis code, from (almost) any chapter of the classification. Some forms of harm that can result from quality and safety events are not adequately represented by a standard ICD-11 diagnosis code. A special set of categories to represent these forms of harm are provided in the injury chapter of ICD-11 (Chapter 22 'Injury, poisoning or certain other consequences of external causes'), under the category titled 'Injury or harm arising from surgical or medical care, not elsewhere classified'. Quality and patient safety causes (sources of harm) fall into four types of causes at the top level that capture events caused by:

1. substances (drugs and medicaments, etc.),
2. procedures,
3. devices, and
4. a mix of other types of causes.

The full quality and safety external cause codes are found in Chapter 23 'External causes of morbidity or mortality' within category titled 'Causes of health care related harm or injury'.

Quality and safety **Mode** or **Mechanism** ('Mode' is the term used in ICD-11 external cause codes) is the second part of the model, and refers to the main way in which the Quality and safety Cause leads to the **Harm** which is represented in the third concept, Quality and safety Harm. Quality and safety **Modes** are specific to the types of Quality and safety **Cause**. Examples are:

**Table 1:** *Examples of corresponding quality and safety mode or mechanism*

<b>Cause or Source of Harm</b>	<b>Mode or Mechanism</b>
Substance	Overdose, underdose, incorrect substance, or harm arising despite correct administration and dosing
Procedure	Unintentional perforation of an organ during a procedure
Device	Dislodgement, malfunction
Other cause	Mismatched blood; Patient dropped during transfer from operating room table

**Examples for the ICD–11 Quality and safety coding model**

The ICD–11 quality and safety coding model is demonstrated by the examples in the following table.

**Table 2:** *Demonstration of the quality and safety model using examples*

Example	Criterion	Detail
1	<b>Case</b>	A woman has been admitted to hospital for stabilisation of diabetes. She is erroneously prescribed three times the usual dose of an antidiabetic medication. The abnormally high dose is given, and the patient has a hypoglycaemic episode
	Harm	Hypoglycaemia in the context of diabetes, unspecified ( <a href="#">5A21.Z</a> )
	Cause	Drugs, medicaments or biologic substances associated with injury or harm in therapeutic use ( <a href="#">PL00</a> ); Medication (use additional code, if desired) - Antidiabetic ( <a href="#">XM8S35</a> )
	Mode	Overdose of substance as mode of injury or harm ( <a href="#">PL13.0</a> )
	Cluster	<a href="#">5A21.Z/PL00&amp;XM8S35/PL13.0</a>
2	<b>Case</b>	Patient presented to hospital with visual hallucinations due to malaria prophylaxis with mefloquine prescribed and taken at the correct dose.
	Harm	Visual hallucinations ( <a href="#">MB27.27</a> )
	Cause	Drugs, medicaments or biological substances associated with injury or harm in therapeutic use ( <a href="#">PL00</a> ); Medication (use additional code, if desired) - Mefloquine ( <a href="#">XM50J2</a> )
	Mode	Drug-related injury or harm in context of correct administration or dosage, as mode of injury or harm ( <a href="#">PL13.2</a> )
	Cluster	<a href="#">MB27.27/PL00&amp;XM50J2/PL13.2</a>
3	<b>Case</b>	A man visits a primary care physician for removal of a skin lump, mainly to exclude the possibility of malignancy. The lesion is excised and the wound is sutured. It later becomes known that the physician had Hepatitis C and the patient has now contracted this disease.
	Harm	Acute hepatitis C ( <a href="#">1E50.2</a> )
	Cause	Biopsy procedure, not elsewhere classified, associated with injury or harm in therapeutic use ( <a href="#">PK81.5</a> )
	Mode	Failure of sterile precautions as mode of injury or harm ( <a href="#">PL11.4</a> )
	Cluster	<a href="#">1E50.2/PK81.5/PL11.4</a>
4	<b>Case</b>	An elderly woman is admitted due to a fractured neck of femur. Surgical fixation is undertaken. The operative site bleeds heavily the day after surgery, requiring return to theatre.
	Harm	Haemorrhage or haematoma of other or unspecified site complicating a procedure, not elsewhere classified ( <a href="#">NE81.0Z</a> ) & <a href="#">XA1673</a> Femoral neck
	Cause	Musculoskeletal procedure associated with injury or harm, open approach ( <a href="#">PK80.80</a> ) (Orthopaedic surgical procedures are included here)

Example	Criterion	Detail
	Mode	Unspecified mode of injury or harm associated with a surgical or other medical procedure ( <a href="#">PL11.Z</a> ) (Note: Select <a href="#">PL11.Z</a> because case documentation does not mention any specific mode or mechanism by which haemorrhage occurred)
	Cluster	<a href="#">NE81.OZ</a> & <a href="#">XA1673</a> / <a href="#">PK80.80</a> / <a href="#">PL11.Z</a>
5	<b>Case</b>	A 63 year old man had a left knee-replacement less than a year ago, because of arthritis. The implanted device has come loose, resulting in pain and reduced function.
	Harm	Pain in joint ( <a href="#">ME82</a> ); Specific Anatomy (use additional code, if desired) Knee joint ( <a href="#">XA8RL1</a> ); Laterality (use additional code, if desired) – Left ( <a href="#">XK8G</a> )
	Cause	Orthopaedic devices associated with adverse incidents, prosthetic or other implants, materials or accessory devices ( <a href="#">PK99.2</a> )
	Mode	Dislodgement, misconnection or de-attachment, as mode of injury or harm ( <a href="#">PL12.4</a> )
	Cluster	<a href="#">ME82</a> & <a href="#">XA8RL1</a> & <a href="#">XK8G</a> / <a href="#">PK99.2</a> / <a href="#">PL12.4</a>
6	<b>Case</b>	A man has bowel cancer. Abdominal surgery was done several days ago to resect the affected part of the colon and re-join the preserved part of the colon. The anastomosis has leaked and required surgical revision.
	Harm	Postsurgical leak ( <a href="#">NE81.3</a> ) (anastomosis leak is an index term)
	Cause	Gastrointestinal, abdominal, or abdominal wall procedure associated with injury or harm in therapeutic use <a href="#">PK80.3Z</a>
	Mode	Unspecified mode of injury or harm associated with surgical or other medical procedure ( <a href="#">PL11.Z</a> ). (Note: Select <a href="#">PL11.Z</a> because case documentation does not mention any specific mode or mechanism by which the anastomotic leak occurred).
	Cluster	<a href="#">NE81.3</a> / <a href="#">PK80.3Z</a> /[ <a href="#">PL11.Z</a> ]
7	<b>Case</b>	Refractory urinary tract infection due to chronic indwelling catheter.
	Harm	Urinary tract infection, site and agent not specified ( <a href="#">GC08.Z</a> )
	Cause	Gastroenterology or urology devices associated with adverse incidents, urinary catheter ( <a href="#">PK93.10</a> )
	Mode	Other specified mode of injury or harm associated with a surgical or other medical device, implant or graft ( <a href="#">PL12.Y</a> ) (Note: Select <a href="#">PL12.Y</a> because none of the more specific mode types appears to lead to infection of device)
	Cluster	<a href="#">GC08.Z</a> / <a href="#">PK93.10</a> / <a href="#">PL12.Y</a>
8	<b>Case</b>	Elderly patient falls out of bed in a hospital and suffers a left hip fracture. The documentation describes that the nurse forgot to put the bedrails in place which lead to the patients fall.

Example	Criterion	Detail
	Harm	Fracture of neck of femur, unspecified ( <a href="#">NC72.2Z</a> ; Laterality (use additional code, if desired) - Left ( <a href="#">XK8G</a> )
	Cause	Other health care related causes of injury or harm ( <a href="#">PL10</a> )
	Mode	Fall in health care ( <a href="#">PL14.E</a> )
	Cluster	<a href="#">NC72.2Z</a> & <a href="#">XK8G/PL10/PL14.E</a>
<b>9</b>	<b>Case</b>	Patient received an infusion of red blood cells and develops severe rigors that subside after an hour. It was discovered that there was a blood mismatch (not ABO or Rh incompatibility).
	Harm	Other serum reactions ( <a href="#">NE80.3</a> )
	Cause	Other health care related causes of injury or harm ( <a href="#">PL10</a> )
	Mode	Mismatched blood used in transfusion ( <a href="#">PL14.3</a> )
	Cluster	<a href="#">NE80.3/PL10/PL14.3</a>
<b>10</b>	<b>Case</b>	Right sided pneumothorax caused by mechanical ventilation in an intensive care setting
	Harm	Pneumothorax, unspecified ( <a href="#">CB21.Z</a> ); Laterality (use additional code, if desired) - Right ( <a href="#">XK9K</a> )
	Cause	Ventilation associated with injury or harm in therapeutic use ( <a href="#">PK81.0</a> )
	Mode	Unspecified mode of injury or harm associated with a surgical or other medical procedure ( <a href="#">PL11.Z</a> )
	Cluster	<a href="#">CB21.Z&amp;XK9K/PK81.0/PL11.Z</a>
<b>11</b>	<b>Case</b>	Patient with neutropenia due to chronic therapy with clozapine.
	Harm	Acquired neutropenia ( <a href="#">4B00.01</a> )
	Cause	Drugs, medicaments or biological substances associated with injury or harm in therapeutic use (P00); Medication (use additional code, if desired) - <a href="#">XM8UG6</a> ]
	Mode	Drug-related injury or harm in the context of correct administration or dosage, as mode of injury or harm ( <a href="#">PL13.2</a> )]
	Cluster	<a href="#">4B00.01/P00&amp;XM8UG6/PL13.2</a>

Note that in each of these examples, a mode/mechanism of harm is coded alongside the cause of harm code for all cases. This is true, even when a mode of harm is not apparent. In the latter situations, a code for 'mode or mechanism of injury unspecified' should be selected, for any of substance-related harm, procedure-related harm, or device-related harm. For the 'other health care related causes' the harm should be coded (from anywhere in the classification) followed by code [PL10](#) *Other health care related causes of injury or harm* followed by the appropriate code from category [PL14](#) *Mode of injury or harm associated with other health care related causes* (where there are several mode options).

### Considerations around distinguishing poisoning versus overdose of drugs, medicaments or biologic substances in the clinical context

It is important to make a distinction between an overdose in the context of clinical care and a poisoning that is not in a clinical context. The former would be coded using codes in the 'Causes of health care related harm or injury' section of Chapter 23, whereas poisonings would be coded in the 'Unintentional causes' or 'Intentional self-harm' sections of Chapter 23.

The following scenarios will help to illustrate the distinction:

1. An adult medical inpatient receives an overdose of a prescribed medication, because an excess dose is inadvertently injected by a nurse.
2. An adult inadvertently takes an overdose of their own prescribed medication, because the physician wrote the prescription incorrectly.
3. An adult inadvertently takes an overdose of their own prescribed medication, because they were given incorrect instructions by the pharmacist.
4. An adult inadvertently takes an overdose of their own prescribed medication, because they misunderstood instructions on the pill bottle and verbal instructions given to them by both the pharmacist and their doctor.
5. An adult inadvertently takes an overdose of their own prescribed medication, and it is unclear from documentation or case investigation as to why a mistake was made.
6. An adult takes an overdose of their own prescribed medication with undetermined intent.
7. An adult intentionally takes an overdose of their own prescribed medication with intent for self-harm.
8. A child ingests a number of pills from his mother's prescribed pill bottle and becomes somnolent.

Scenario 1 is clearly an overdose arising from an error in a health care context, while scenario 8 is clearly a poisoning of a child who is not in a therapeutic health care context.

Scenario 7 should also be coded as an episode of poisoning, because the pills were not taken with a therapeutic intent, but with intent for self-harm (the 'Intentional self-harm' concept overrides other considerations).

Scenarios 2 and 3 are overdoses arising from problems in a health care context (and are coded using the 'Causes of health care related harm or injury' codes). In both scenarios, the context is one of medication treatment, and the actions of health care providers.

Scenarios 4, 5 & 6 are less straightforward, though rather common in patient care. The context of the medication use is still clearly that of treating a medical condition and the fact that the medication was prescribed to the patients makes it a context of therapeutic use (provided there is no mention of intentional self-harm). Because of the therapeutic context, these scenarios should be coded using the 'Causes of health care related harm or injury' codes, rather than poisoning codes.



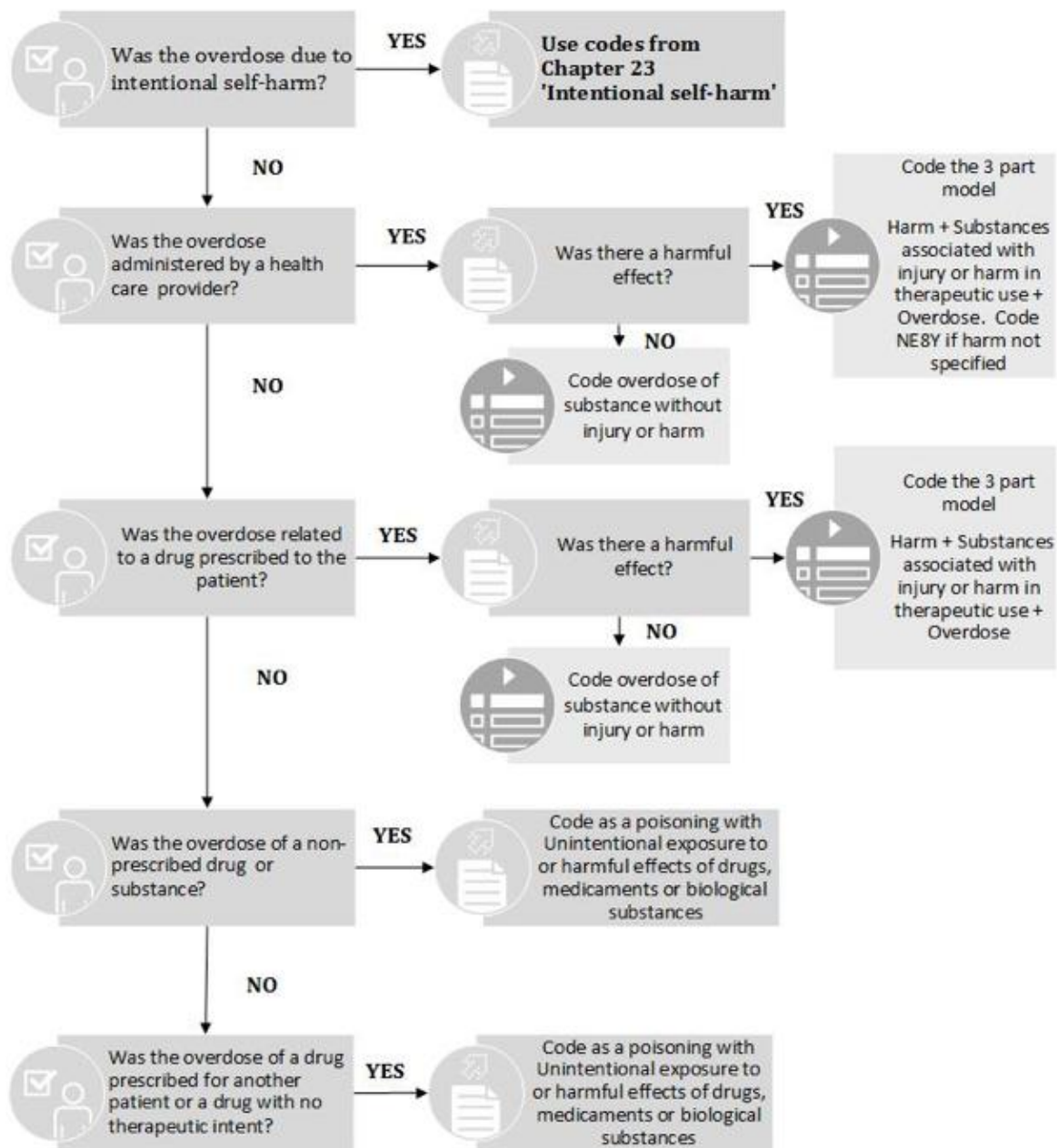

### Overdose Flowchart

**Figure 1:** Flowchart for coding poisoning versus overdose.

### Instructions on when the three-part quality and safety model applies, and when it does not

The above sections and examples describe scenarios in which an aspect of care (a drug, procedure, device, or other aspect of care) has been causally linked to a condition that a patient has developed. In many instances, however, conditions arise in the health care setting without explicit documentation suggesting a causal link to an aspect of care. Specific examples include:

- pulmonary embolism arising two days after a surgical procedure
- atrial fibrillation after surgery
- low blood pressure one day after administration of a drug
- pneumonia developing on day four of a hospital stay
- urinary tract infection arising in hospital without any mention of catheters

In each of these examples, the three-part model for quality and safety would NOT apply if there is no explicit documentation asserting a causal link to another aspect of care, whether that is a drug, procedure, device, or other aspect of care. Importantly, the mere mention of a surgical procedure or a drug administration in the above examples, does NOT mean that those factors played a causal role, because the clinical statements merely declare timing of the diagnosis, with descriptive words like ‘after’, ‘following’, ‘occurring on day XX’. In such cases, the correct coding of the conditions would be to code the medical condition from any chapter from ICD-11 along with an extension code for timing (in particular, the extension codes for diagnoses arising during a hospital stay, plus or minus the optional extension codes for intraoperative or postoperative timing of a diagnosis).

The above examples would be coded in the following way:

- [BB00.0](#) Acute pulmonary thromboembolism &[XY69](#) Developed after admission &[XY7V](#) Postoperative
- [BC81.3](#) Atrial fibrillation &[XT5R](#) Acute &[XY69](#) Developed after admission &[XY7V](#) Postoperative
- [BA2Z](#) Hypotension, unspecified &[XY69](#) Developed after admission
- [CA40.Z](#) Pneumonia, organism unspecified &[XY69](#) Developed after admission
- [GC08.Z](#) Urinary tract infection, site and agent not specified &[XY69](#) Developed after admission

### 2.23.20.2 Causation in the context of quality and safety

There are nuances of language in documentation that will indicate whether there is a causal link between a cause and harm.

#### Connecting terms implying a causal relationship

A causal relationship is strongly suggested by the following terms:

<b>Terms</b>	<b>Additional Notes</b>
as (a) complication of, complicated by, complicating, complication(s) of	-
as a cause of, cause of, caused, caused by, causing	-
as a result of, resulted in, resulting in, with resultant, with resulting	-
because of	-
due to	-
from	-
induced, induced by	-
leading to, led to	-
related to,	-
precipitated by	-
producing	-
secondary to	-
likely related to	Coding judgment call. However, the clinician is making a causal inference with this term
possibly secondary to, probably secondary to	Coding judgment call. However, the clinician is making a causal inference with this term
may be the reason for	Coding judgment call. However, the clinician is making a causal inference with this term

### **Connecting terms where the causal relationship is unclear**

Occasionally there may be connecting terms that hint at causation, but without explicit assertion of a causal link. Examples are shown below. In these circumstances, coders need to check with the documenting clinician, or look for supplementary wording or ancillary information that implies causation.

#### **Terms**

Associated with

Accompanied by

Incidental to

### **Connecting terms NOT implying a causal relationship**

In clinical documentation, terms are often used to describe a temporal association. The many terms listed in the preceding table (from 'connecting terms implying a causal relationship') are connecting terms that do suggest a causal association that is typically also a temporal association. In contrast, there are a number of terms that describe only temporal associations. Examples of such terms are listed below:

**Terms**

after

also

and

during

with

arising in or during

consistent with

followed by, following

incurred after/during/in/when

occurred after/during/in/when/while

postoperatively, postoperative, occurred post-op

If connecting terms of this sort appear in clinical documentation without any of the causal connectors discussed earlier, avoid using the three-part quality and safety model.

Terms like ‘postoperative’, ‘post-op’, ‘postprocedural’, etc., are a special situation because these have historically been considered, in some coding systems to be indicative of a causal link. However, as noted in the specific examples above, conditions such as urinary tract infection, pneumonia, and atrial fibrillation may temporally arise after surgery, without necessarily being caused by surgery. It is for this reason that the guidelines presented here instruct coders to look for explicit causal connections. (Importantly, postoperative conditions such as pneumonia, urinary tract infection, and atrial fibrillation can still be coded with informative extension codes that specify timing – i.e. ‘arising during hospital stay’ and/or ‘postoperative’—and permit the derivation of adverse events in indicators in data analysis).

**Other specific situations where the clinical context implies a causal relationship**

There are some clinical situations where there may not be connecting terms that explicitly point to causation, but where the clinical circumstances nevertheless clearly point to causation. Some examples appear below:

**Specific situations**

failed device

infected device

loose screws

postprocedural bleeding

post-op wound infection

dehiscence

wound hematoma

In each of these, it is clear that the situation would not have occurred in the absence of a procedure or a device problem. Accordingly, the three-part quality and safety model should be applied.

In contrast, conditions such as postoperative pneumonia or postoperative pulmonary embolism, or postoperative atrial fibrillation are different than the specific situations listed in the table above. This is because problems such as pneumonia, pulmonary embolism, or atrial fibrillation can be triggered by factors unrelated to the surgical procedure (i.e. different from a ‘wound’ that is without question caused by surgery).

### 2.23.20.3 Chronic postprocedural conditions

There are many chronic clinical conditions that occur either as a consequence of specific procedures and techniques or as a result of the removal of an organ, e.g. postmastectomy lymphedema syndrome, postirradiation hypothyroidism. In many instances, codes for such chronic postprocedural conditions are in ICD-11 within various body system chapters.

Examples include:

- [BE10](#) Postcardiotomy syndrome
- [5D40.Z](#) Postprocedural hypothyroidism, unspecified
- [GC72](#) Postprocedural urethral stricture
- [GC70](#) Postoperative adhesions of vagina

These are, by their very nature, precoordinated codes that capture both the a clinical condition and the notion of it being caused by a procedure. It is possible to use such codes on alone without any clustering. However, coders can use the three-part model with such codes to add specificity. The model allows the addition of more specificity about the specific type of surgical procedure that caused the condition, and also the mode through which the procedure caused the condition.

**Example 1:** Urethral stricture due to previous radiation for treatment of prostate cancer.

Code to [GC72](#) Postprocedural urethral stricture Further detail can be added to the code [GC72](#) with the addition of: [PK81.C](#) *Radiation therapy associated with injury or harm in therapeutic use* and [PL11.Y](#) *Other specified mode of injury or harm associated with a surgical or other medical procedure* Cluster: [GC72/PK81.C/PL11.Y](#)

Note, however, that there will occasionally be instances where it is entirely unnecessary to use the three-part model because the code for the chronic postprocedural condition already contains full clinical detail. For example:

- [9D21](#) *Cataract lens fragments in eye following cataract surgery* (for this, it would be highly redundant to code “ophthalmic procedure” and a corresponding mode, given all the detail that is inherently embedded in this single code).
- [EL61](#) *Chronic radiodermatitis following radiotherapy* (again, redundant to code “radiation therapy” as the procedure causing harm, and “mode unspecified” for this case).

In relation to the two preceding examples, we reiterate that the overriding recommendation is that the three-part model should be used whenever possible. Coders must simply make a case by case judgement when it is obvious to them that the added procedure code and mode code are redundant.

#### 2.23.20.4 Adverse events and circumstances in health care that do not cause actual injury or harm

There are instances in the context of health care where things happen to patients, and where problems arise, but where there is no actual adverse consequence to the patient as a recorded medical condition. Specific examples include:

- A fall in the health care setting without fracture or other injury
- An incorrect drug administered without harm to patient
- A drug given to the wrong patient without harm to the patient
- A delay in drug administration without negative effect on clinical course
- Documented failure of sterile precautions in a surgical procedure without ensuing infection
- Dislodged orthopaedic device without symptoms or problems
- Inadvertent needle stick without documented injury or other harm

In these circumstances, codes should be chosen from Chapter 24 Factors influencing health status or contact with health services in the section of codes entitled 'Health care related circumstances influencing the episode of care, without documented injury or harm'. These codes are organised using the four categories of health care related harm that appear in Chapter 23 External causes of morbidity or mortality (drugs, devices, procedures and other health care related causes), but with the important distinction that the circumstances being described through coding did NOT cause actual harm to the patient.

The above examples would be coded in the following way:

- [QA8E](#) Fall in health care without injury or harm
- [QA72](#) Incorrect substance without injury or harm
- [QA8D](#) Patient received diagnostic test or treatment intended for another patient without injury or harm
- [QA8B](#) Delayed treatment without injury or harm
- [QA52](#) Failure of sterile precautions without injury or harm
- [QA62](#) Dislodgement, misconnection or de-attachment without injury or harm
- [QA8F](#) Needle stick without injury or harm

**Figure 1:** Summary algorithm for coding events and conditions that arise in the context of health care

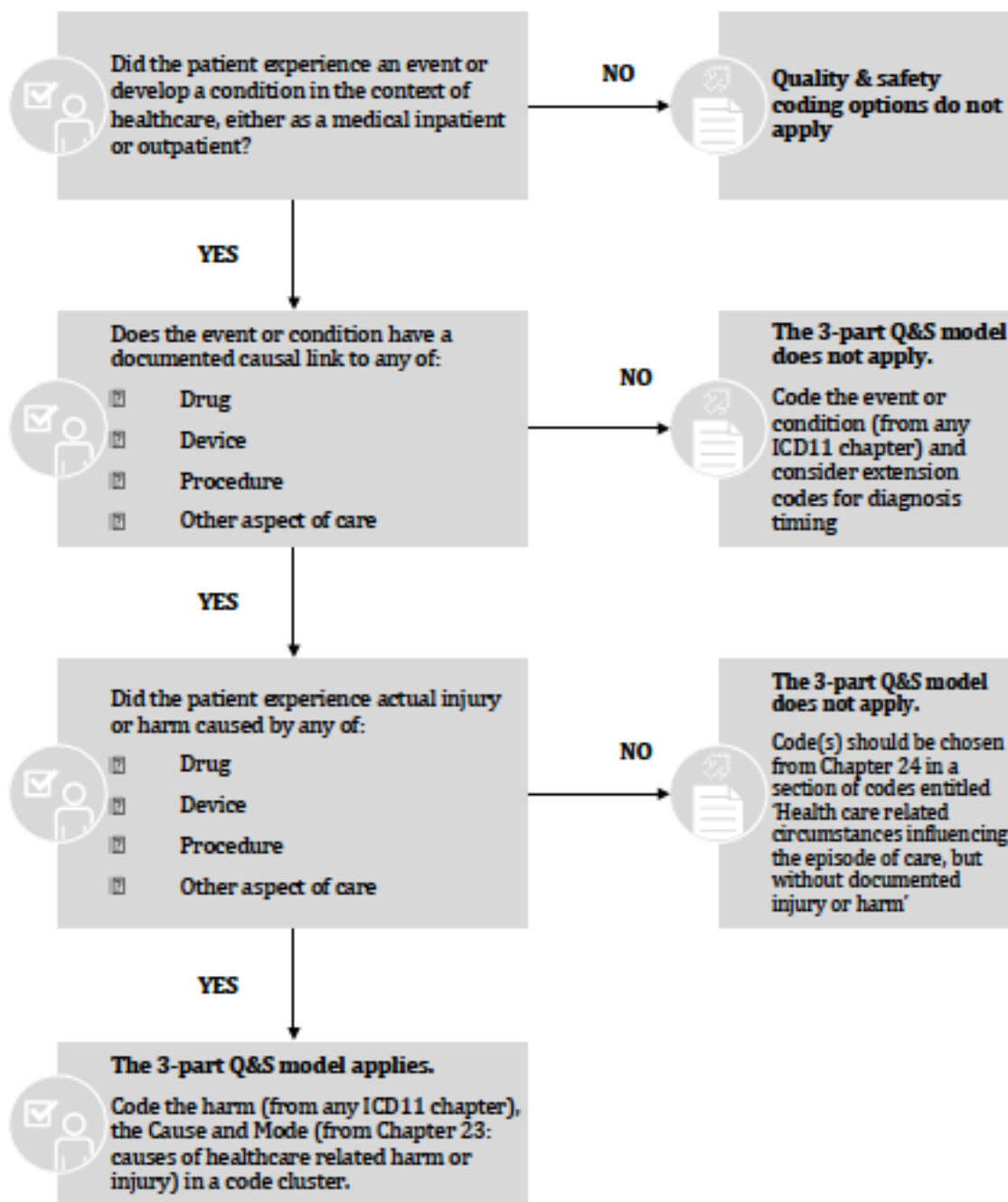

### Q&S Algorithm

#### 2.23.20.5 Recommendations for data capture and organisation

Information systems must be capable of capturing the three components and marking the three codes as belonging to the same cluster (see also instructions for postcoordination and cluster coding).

### 2.23.21 Chapter-specific notes

Coder guidance is given below for specific chapters where problems may be encountered in selecting preferred 'main condition' codes. The preceding general guidelines and rules apply to all chapters unless a specific chapter note states otherwise.

#### 2.23.21.1 Chapter 1: Infectious and parasitic diseases

##### *Human immunodeficiency virus [HIV] disease*

A patient with a compromised immune system due to HIV disease may sometimes require treatment during the same episode of care for more than one disease, for example mycobacterial and cytomegalovirus infections. Only subcategories for HIV disease associated with tuberculosis and malaria are precoordinated in this block for HIV disease. When another specified HIV-caused disease is documented by the health care practitioner, postcoordinate the HIV-caused disease with the appropriate subcategory for HIV disease as recorded by the health care practitioner.

##### **Example 1:**

The patient has HIV disease and is admitted for treatment of Kaposi sarcoma of the soft palate.

Main condition: Kaposi sarcoma due to HIV disease

Kaposi sarcoma is documented as an HIV-caused disease. Therefore, the stem code for Kaposi sarcoma is postcoordinated with the applicable stem code for HIV.

Main condition: [2B57.Y](#) Kaposi sarcoma of other specified primary sites & [XA8HL5](#) Soft palate / [1C62.3](#) HIV disease clinical stage 4 without mention of tuberculosis or malaria.

##### **Example 2:**

The patient has HIV disease and is admitted for treatment of toxoplasmosis.

Main condition: Toxoplasmosis due to HIV

Main condition: [1F57.Z](#) Toxoplasmosis, unspecified / [1C62.3](#) HIV disease clinical stage 4 without mention of tuberculosis or malaria

##### *Sepsis with or without septic shock*

The concept of sepsis has undergone major changes during the last decades and the current description established and widely accepted internationally in 2016 is that sepsis is a life-threatening organ dysfunction caused by a dysregulated host response to infection.

Sepsis is not considered to be a disease in itself, but a reaction to an infectious disease which may be of bacterial, viral, fungal or protozoal aetiology. Septic shock is defined as a subset of sepsis in which circulatory, cellular and metabolic abnormalities are profound enough to substantially increase mortality.

A cluster involving a case of documented sepsis should include:



- First, a stem code representing the causing infection (specified or unspecified) and as applicable, an optional extension code for the infectious agent if it is known.
- Second, a stem code for sepsis with or without septic shock depending on the documentation

*Note:* If the causing infection is documented as generalised or a specific infection is not documented, assign a stem code for greatest level of specificity documented in relation to the infection.

#### **Example 1:**

Patient admitted for treatment of pneumococcal pneumonia causing sepsis

Main condition: Pneumococcal pneumonia causing sepsis

Code first the causing infection, [CA40.07](#) *Pneumonia due to Streptococcus pneumoniae* and postcoordinate with the stem code for [1G40](#) *Sepsis without septic shock*

Main condition cluster: [CA40.07/1G40](#)

#### **Example 2:**

Patient admitted for treatment of severe influenza A H1N1 causing sepsis.

Code first the causing infection, Influenza [1E30](#) *Influenza due to identified seasonal influenza virus* with optional extension code for ([XN297](#) *Influenza A H1N1 virus*) and postcoordinate with the stem code for ([1G40](#) *Sepsis without septic shock*)

Main condition cluster: [1E30 &XN297/1G40](#)

#### **Example 3:**

Patient admitted for treatment of sepsis due to E.coli.

Main condition: Sepsis due to E Coli.

Code first the causing infection. In this example, a specific infection is not documented; therefore a code for ([1C41](#) *Bacterial infection of unspecified site*), is coded with optional extension code for ([XN6P4](#) *Escherichia coli*) and postcoordinate with the stem code for ([1G40](#) *Sepsis without septic shock*).

Main condition cluster [1C41&XN6P4/1G40](#)

#### **Example 4:**

Patient presented with septic shock and died shortly after admission.

Main condition: Septic shock, unknown infection

Code first the causing infection. In this example, a specific infection is unknown; therefore, a code for [1H0Z *Infection, unspecified*] and then postcoordinate with the code for ([1G41](#) *Sepsis with septic shock*)

Main condition cluster: [1H0Z] / [1G41](#)

### **2.23.21.2 Chapter 2: Neoplasms**

When coding neoplasms, refer to the instructions regarding code assignment at the level of the individual categories, and the use of additional morphological or site descriptions from the extension codes. A neoplasm, whether primary or metastatic, that is the focus of care during a relevant episode of health care, should be recorded.

When the 'main condition' recorded by the health care practitioner is a primary neoplasm and the 'other condition' is a secondary neoplasm (metastasis), code each neoplasm

separately. Do not postcoordinate the stem code for primary neoplasm with the stem code for secondary neoplasm.

When the main condition recorded by the health care practitioner is a secondary neoplasm (metastasis) and the primary neoplasm is no longer present (having been removed during a previous episode of care or where the documentation indicates a personal history of that neoplasm), code the secondary neoplasm (metastasis) as the main condition and separately code as an other condition the stem code for 'personal history of'. Do not postcoordinate the stem code for secondary neoplasm with the stem code for 'personal history of'. (See example below). Also, refer to Section [2.23.16 Coding 'History of' and 'Family history of'](#) for further coding direction.

When the main condition recorded by the health care practitioner is 'Follow-up examination' (a circumstance codable to Chapter 24 'Factors influencing health status or contact with health services') and the 'other condition' recorded is a 'personal history of', code the applicable 'follow-up examination' code as the main condition and separately code the stem code for 'personal history of' as the other condition. Do not postcoordinate the 'follow-up examination' stem code with the stem code for 'personal history of'. Refer to Section [2.23.16 Coding 'History of' and 'Family history of'](#) for coding direction.

#### **Example 1:**

A patient is admitted for investigation of a lump in the breast. Investigation concludes a malignancy in the left breast. Mastectomy is performed and histopathology shows an invasive ductal carcinoma which has spread to regional lymph nodes (left axilla). Chemotherapy is planned.

Main condition: Invasive ductal carcinoma

Other condition: Metastases to regional lymph nodes

Procedure: Mastectomy

Code the main condition as invasive ductal carcinoma with optional extension code 'left'. ([2C61.0&XK8G](#)). Cluster code secondary malignancy in axillary lymph nodes with optional extension code 'left' as other condition ([2D60.3&XK8G](#)).

#### **Example 2:**

Patient who has a history of carcinoma of breast resected two years ago is admitted for a bronchoscopy with biopsy. Investigation revealed secondary carcinoma in lung.

Main condition: Secondary carcinoma in lung

Other conditions: Carcinoma of breast resected two years ago

Procedure: Bronchoscopy with biopsy

Code the main condition as [2D70 Malignant neoplasm metastasis in lung] . Code [QC40.3](#) *Personal history of malignant neoplasm of breast* as another condition and postcoordinate the stem code [2C6Z](#) *Malignant neoplasms of breast, unspecified* to specify the personal history is related to malignant primary breast cancer. Refer to Section [2.23.16 Coding 'History of' and 'Family history of'](#). Main condition: [2D70](#) Other condition: Option 1: [QC40.3](#); Option 2: [QC40.3/2C6Z](#)

#### **Example 3:**

Patient is admitted for bladder cancer recheck by cystoscopy. The patient has a history of previously excised bladder cancer. No evidence of recurrence seen.

Main condition: Follow-up examination by cystoscopy

Other conditions: History of bladder cancer

Procedure: Cystoscopy

Code the main condition as [QA06](#) *Follow-up examination after treatment for malignant neoplasms*. Option 1: Code [QC40.5](#) *Personal history of malignant neoplasm of urinary tract*. Option 2: Code [QC40.5](#) *Personal history of malignant neoplasm of urinary tract* as an other condition and postcoordinate the stem code [2C94.Z](#) to specify the personal history is related to bladder cancer. Refer to Section [2.23.16 Coding 'History of' and 'Family history of'](#). Main condition: [QA06](#) Other condition: Option 1: [QC40.5](#); Option 2: [QC40.5/2C94.Z](#)

### **Malignant neoplasms of independent, multiple primary sites**

The stem code for Malignant neoplasms of independent (primary) multiple sites should be coded as the main condition when the health care practitioner records as the main condition two or more independent primary malignant neoplasms, none of which predominates. Then, optionally, additional codes to identify the individual neoplasms may be coded as other conditions to identify the individual primary malignant neoplasms recorded by the health care practitioner. Extension codes may be added to each primary malignant neoplasm stem code to identify additional detail of the histopathology and the site.

#### **Example 1:**

The documentation states that the patient has carcinomatosis of the peritoneum from an unknown primary neoplasm.

Main condition: Carcinomatosis of peritoneum

Code the main condition as [2D91](#) *Malignant neoplasm metastasis in peritoneum*. Code as another condition [[2D4Z](#) *Unspecified malignant neoplasms of ill-defined or unspecified sites*]. Main condition: [2D91](#) Other condition: [2D4Z](#)

#### **Example 2:**

Main condition: Multiple myeloma

Other conditions: Primary adenocarcinoma of prostate

Code the main condition as [[2A83.1](#) *Plasma cell myeloma*]. Code as an other condition [[2C82.0](#) *Adenocarcinoma of prostate*]. Main condition: [2A83.1](#) Other condition: [2C82.0](#)

### **Unspecified malignant neoplasms of unspecified sites**

This code should be used only when the health care practitioner has clearly recorded the neoplasm as an unknown primary site or as an unspecified malignancy, assumed primary.

### **Malignant neoplasm metastases, unspecified site**

This code should be used as the main condition only when the malignancy is described as 'disseminated metastases' or 'metastatic carcinoma' (or other similar terms as described in the inclusion list of the code) but the specific sites are not documented.

## **2.23.21.3 Chapter 3: Diseases of the blood or blood-forming organs**

Certain conditions classifiable to this chapter may result from drugs or other external causes. Codes from Chapter 23 'External causes of morbidity and mortality' may be used as optional additional codes.

#### **Example 1:**

Patient who is on long-term treatment with the drug trimethoprim is admitted and treated for trimethoprim-induced folate deficiency anaemia. Main condition: Trimethoprim-induced folate deficiency anaemia Code the main condition as [*3A02.4 Drug-induced folate deficiency anaemia*] and postcoordinate with the external cause code [*PL00 Drugs medicaments and biological substances associated with injury or harm in therapeutic use*] and the external cause code [*PL13.2 Drug-related injury or harm in context of correct administration or dosage, as mode of injury or harm*]. The extension code [*XM7NY9 Trimethoprim*], may be added optionally to identify the drug. Main condition cluster: [3A02.4 /PL00&XM7NY9 /PL13.2](#)

#### 2.23.21.4 Chapter 5: Endocrine, nutritional or metabolic diseases

Certain conditions classifiable to this chapter may result from drugs or other external causes. Codes from Chapter 23 'External causes of morbidity and mortality' may be used as optional additional codes.

##### *Diabetes mellitus*

When the health care practitioner has documented a condition as due to diabetes mellitus, postcoordinate the condition and the diabetes mellitus stem codes. If more than one condition is documented as being due to diabetes mellitus, each distinct clinical concept (each diabetes caused condition) is coded on its own and postcoordinated with the diabetes mellitus stem code even though it means repeating the diabetes code in each cluster. (Refer to Example 2 below).

##### **Example 1:**

Main condition: Chronic kidney failure due to type 2 diabetes mellitus. Chronic kidney failure is documented as due to diabetes mellitus; therefore, code to [GB61.Z](#) *Chronic kidney disease, stage unspecified* and postcoordinate with the stem code [5A11](#) Type 2 diabetes mellitus. Main condition cluster: [GB61.Z/5A11](#)

##### **Example 2:**

Main condition: Type 1 diabetes with diabetic nephropathy Other condition: Diabetic cataract Code the main condition as [5A10](#) *Type 1 diabetes mellitus* postcoordinated with the stem code [GB61.Z](#) *Chronic kidney disease, stage unspecified*. Code as an other condition [9B10.21](#) *Diabetic cataract* postcoordinated with the stem code [5A10](#) *Type 1 diabetes mellitus*. Main condition cluster: [5A10/GB61.Z](#) Other condition cluster: [9B10.21/5A10](#)

##### **Carcinoid syndrome**

This code is not to be used as the preferred code for main condition if a carcinoid neoplasm is recorded, unless the episode of care was directed predominantly at the endocrine syndrome itself.

#### 2.23.21.5 Chapter 6: Mental, behavioural or neurodevelopmental disorders

##### *Dementia*

Always code the underlying aetiology, if documented.

#### 2.23.21.6 Chapter 8: Diseases of the nervous system

Certain conditions classifiable to this chapter may result from the effects of drugs or other external causes. Codes from Chapter 23 'External causes of morbidity and mortality' may be used as optional additional codes.

### *Late effect of cerebrovascular disease*

These codes are not to be used as the preferred code for the 'main condition' if the nature of the residual condition is recorded. Refer to Section [2.23.18 Coding of conditions documented as sequela \(late effect\)](#).

### *Paralytic symptoms*

These codes are not to be used as the preferred code for the main condition if a current cause is recorded, unless the episode of care was mainly for the paralysis itself.

#### **Example 1:**

Patient is admitted with left side hemiplegia and following investigation determined to be due to acute ischaemic stroke. Main condition: Acute ischaemic stroke with hemiplegia. Code the main condition as [8B11.5Z Cerebral ischaemic stroke, unspecified](#) and postcoordinate the stem code [MB53.Z Hemiplegia, unspecified](#). An optional extension code to specify [XK8G Left](#) may be added. Main condition cluster: [8B11.5Z Cerebral ischaemic stroke, unspecified](#)/[MB53.Z](#)&[XK8G](#)

#### **Example 2:**

Patient is admitted for rehabilitation training for paralysis of left leg resulting from cerebral infarction three years ago. Main condition: Paralysis of left leg Code the main condition as [MB55.Z Monoplegia of lower extremity, unspecified](#) and an optional extension code to specify [XK8G Left](#) may be added. Postcoordinate the stem code [8B25.0 Late effects of cerebral ischemic stroke](#) Main condition cluster: [MB55.Z](#)&[XK8G](#)/[8B25.0](#)

## **2.23.21.7 Chapter 9: Diseases of the visual system**

### *Vision impairment including blindness*

These codes are not to be used as the preferred code for the main condition if the cause is recorded, unless the episode of care was mainly for the blindness itself.

## **2.23.21.8 Chapter 10: Diseases of the ear or mastoid process**

### *Acquired hearing impairment*

These codes are not to be used alone if the cause is recorded, unless the episode of care was mainly for the hearing loss itself.

## **2.23.21.9 Chapter 11: Diseases of the circulatory system**

### *Secondary hypertension*

This code is not to be used as the preferred code for the main condition if the cause is recorded. When coding to the cause, secondary hypertension is used as an additional code (in a cluster) to indicate that this manifestation has been relevant in the context of treatment.

## **2.23.21.10 Chapter 15: Diseases of the musculoskeletal system or connective tissue**

Many musculoskeletal conditions are treated without knowing the underlying disease. In such cases only the musculoskeletal condition is coded.

## 2.23.21.11 Chapter 18: Pregnancy, childbirth or the puerperium

### JA05 *Complications following abortion, ectopic or molar pregnancy*

These codes are not to be used as the preferred code for the main condition, except where a new episode of care is solely for treatment of a complication, e.g. a current complication of a previous abortion. These codes may be used as an optional additional code with 'Abortive outcome of pregnancy' codes to identify associated complications and to give fuller details of the complication.

#### **Example 1:**

Main condition: Ruptured tubal pregnancy causing shock

Other conditions: -

Specialty: Gynaecology

Code the main condition as [JA01.1](#) *Tubal pregnancy* and since the shock is documented as a complication of the tubal pregnancy, postcoordinate [JA05.3](#) *Shock following abortion, ectopic or molar pregnancy*.

Main condition cluster: [JA01.1](#)/[JA05.3](#)

#### **Example 2:**

Patient is diagnosed with endometritis following a spontaneous abortion that was diagnosed and treated at a previous episode of care.

Main condition: Endometritis following spontaneous abortion

Specialty: Gynaecology

This example represents a new episode of care solely for treatment of a current complication of a previous spontaneous abortion; therefore, code the main condition as [JA05.0](#) *Genital tract or pelvic infection following abortion, ectopic or molar pregnancy*. No other code is required since the abortion took place during a previous episode of care.

Main condition: [JA05.0](#)

#### *Delivery*

Use of these codes to describe the 'main condition' should be limited to cases where the only information recorded is a statement of delivery or the method of delivery. These codes may be used as additional codes to indicate a method or type of delivery where no separate data item or procedural classification is being used for this purpose.

#### **Example 3:**

Patient is admitted in labour and delivers a healthy newborn without complication.

Main condition: Normal delivery

Other conditions: -

Procedure: Spontaneous vaginal delivery

Code [JB20.Z](#) *Single spontaneous delivery, unspecified* as 'main condition' and postcoordinate [QA46.0](#) *Single live birth*.

Main condition cluster: [JB20.Z](#)/[QA46.0](#)

#### **Example 4:**

Patient who has a history of previous caesarean section is admitted for in labour. A trial of labour is unsuccessful for vaginal delivery due to arrested active phase and unplanned repeat Caesarean section is performed.

Main condition: Failed trial of labour, unspecified

Other conditions: Secondary uterine inertia

Procedure: Caesarean section

Code [JB0D.8](#) *Failed trial of labour, unspecified* as the 'main condition' and postcoordinate [JB02.1](#) *Secondary uterine inertia* because the health care practitioner has documented the cause of the failed trial of labour. Code [JB22.Z](#) as an other condition to indicate the method of delivery.

Main condition cluster: [JB0D.8](#)/[JB02.1](#)

Other condition: [JB22.Z](#)

### Example 5:

Patient who is known to have a twin pregnancy is admitted in labour and delivers two healthy newborns.

Main condition: Multiple delivery, all spontaneous

Other conditions: Twins, both liveborn

Procedure: Spontaneous delivery

Code [JB24.0](#) *Multiple delivery, all spontaneous*/[QA46.2](#)

Main condition cluster: [JB24.0](#)/[QA46.2](#)

### Example 6:

Patient is admitted in labour at 38 weeks gestation. On examination, no fetal heart rate could be detected.

Main condition: Maternal care for fetal death

Other conditions: -

Procedure: Spontaneous delivery

Code to [JA86.3](#) *Maternal care for intrauterine death* and postcoordinate [XT6G Duration of pregnancy more than 36 completed weeks] . Code as an other condition [JB20.Z](#) *Single spontaneous delivery, unspecified* to indicate the method of delivery.

Main condition: [JA86.3](#) & [XT6G](#)

Other condition: [JB20.Z](#)

*Certain maternal diseases classifiable elsewhere but complicating pregnancy, childbirth or the puerperium*

The subcategories provided should be used as 'main condition' codes in preference to categories outside Chapter 18 'Pregnancy, childbirth or the puerperium' when the conditions being classified have been indicated by the health care practitioner to have complicated the pregnant state, to have been aggravated by the pregnancy, or to have been the reason for obstetric care. The pertinent codes from other chapters may be used as optional additional codes to allow specification of the condition. Postcoordination applies when the additional code to specify the condition is coded.

### Example 7:

Patient is admitted at 28 weeks gestation with toxoplasmosis.

Main condition: Toxoplasmosis

Other conditions: Pregnancy undelivered

Code [JB63.6Z](#) *Protozoal diseases complicating pregnancy, childbirth or the puerperium, unspecified* as the main condition and optionally, code [1F57.Z](#) *Toxoplasmosis, unspecified* to identify the specific protozoal disease that is complicating the pregnancy. When the additional code to identify the specific complication is coded, then postcoordination applies because [1F57.Z](#) is adding additional detail/specificity to the stem code [JB63.6Z](#).

Main condition cluster: [JB63.6Z/1F57.Z](#)

### 2.23.21.12 Chapter 21: Symptoms, signs or clinical findings, not elsewhere classified

Categories from this chapter should not be used as 'main condition' codes unless the symptom, sign or clinical finding was clearly the main condition treated or investigated during an episode of care. Codes from this chapter should not be assigned where an explanatory diagnosis is determined during the episode of care.

### 2.23.21.13 Chapter 22: Injury, poisoning or certain other consequences of external causes

Where multiple injuries are recorded and no one of these has been selected as the 'main condition', code to one of the categories provided for statements of multiple injuries of:

- same type to the same body region;
- different types to the same body region; and
- same type to different body regions

and postcoordinate the stem codes that describe each individual injury.

Note the following exceptions:

- for internal injuries recorded with superficial injuries and/or open wounds only, code to internal injuries as the 'main condition';
- for fractures of skull and facial bones with associated intracranial injury, code to the intracranial injury as the 'main condition';
- for intracranial haemorrhage recorded with other injuries to the head only, code to intracranial haemorrhage as the 'main condition';
- for fractures recorded with open wounds of the same location only, code to fracture as the 'main condition'.

When the multiple injury categories are used, codes for any individual injuries listed are used as additional codes in the same cluster.

#### Example 1:

Patient suffered injuries to the bladder and urethra following an assault. Main condition: Injury to bladder and urethra Other conditions: - Code as main condition [NB92.8](#) *Injury of multiple pelvic organs* and postcoordinate the stem codes for [NB92.2Z](#) *Injury of bladder, unspecified* and [NB92.3Z](#) *Injury of urethra, unspecified* as these codes are adding additional detail/specificity to [NB92.8](#). Main condition cluster: [NB92.8/NB92.2Z](#)

#### Example 2:

Patient, who was the driver of a motorcycle, lost control on the highway and crashed. Investigations revealed open intracranial wound with cerebellar haemorrhage. Main condition: Open intracranial



wound with cerebellar haemorrhage Other conditions: - Code the main condition [NA07.82 Traumatic haemorrhage in cerebellum](#). Code the other condition [NA07.Y Other specified intracranial injury](#).

### 2.23.21.14 Chapter 23: External causes of morbidity or mortality

These codes are not to be used as 'main condition' codes. They are intended for use as additional codes to identify the external cause of conditions classified in Chapter 22 and may also be used as optional additional codes with conditions classified in any other chapter, but which have an external cause.

### 2.23.21.15 Chapter 24: Factors influencing health status or contact with health services

There are some health care episodes that are not related to the treatment of or investigation for current illness or injury (e.g. monitoring of previously-treated conditions, immunisation visits, seeking of health-related advice). In such circumstances, a code for the main condition can potentially be found in Chapter 24 'Factors influencing health status and contact with health services'.

### 2.23.22 Traditional Medicine Conditions - Module 1 (TM1)

Traditional Medicine (TM) is an integral part of health services provided in many countries. International standardisation by including Traditional Medicine conditions within the ICD allows for measuring, counting, comparing, formulating questions and monitoring its use over time. ICD-11's supplementary chapter on Traditional Medicine disorders and patterns (TM1) is designed to be used in conjunction with the Western Medicine concepts of ICD Chapters 01-25.

As with other ICD chapters, the TM1 chapter is a tool for classifying, diagnosing, counting, communicating and comparing TM conditions, it will also assist research and evaluation to assess the safety and efficacy of TM. This chapter not judging or endorsing TM practice or the efficacy of any TM intervention.

### 2.23.23 Use in Traditional Medicine

#### **Reporting at regional, national and international levels:**

- Counting episodes of care for Traditional Medicine disorders and/or patterns in the same way as for Western Medicine diseases for morbidity data reporting purposes
- Counting episodes of care by Traditional Medicine practitioners who may use a combination of Western Medicine and Traditional Medicine terminology
- Describing and quantifying utilisation of Traditional Medicine services and reasons for encounter
- Monitoring use of resources for Traditional Medicine services
- Standardising descriptions of disorders and patterns among TM clinicians, practitioners and coders

#### **Research:**

- Facilitating evidence-based research on safety and efficacy of Traditional Medicine interventions
- Allowing clinical research within the Traditional Medicine framework and integrating Western Medicine with Traditional Medicine
- Understanding interrelationships between Western Medicine diseases and Traditional Medicine disorders and patterns
- Studying treatment patterns and outcomes for specific disorders and patterns using ICD-11 in conjunction with country specific procedure classifications and the TM component of the International Classification of Health Interventions (ICHI)

**Casemix reimbursement and insurance:**

- There are precedents in China, Japan, and Korea for use of existing Traditional Medicine classifications (with or without Western Medicine concepts) for reimbursements to hospitals and for insurance claims and for clinical costing measures.
- Incorporating Traditional Medicine as a chapter of ICD-11 allows much greater scope for describing patient conditions (diseases, disorders (TM1) and patterns (TM1) across the Western Medicine and TM1 chapters) as well as complications and comorbidities.

**Quality and safety of care:**

- Standardising use of codes reflecting quality and safety of care between Western Medicine diseases and TM1 disorders will allow TM practitioners to interpret data from ICD-11 on quality, safety, and efficacy of care.

**Education:**

- Educating TM practitioners in regard to standardisation of diagnosis
- Educating TM clinicians and coders in application and interpretation of ICD-11 data.

**Standardising terminology for use in electronic health records:**

- To enable more consistent and efficient recording and extraction of data
- To allow computer assisted coding of TM1 disorders and patterns

**2.23.24 Coding instructions for Traditional Medicine conditions - Module 1 (TM1)**

Codes from the Traditional Medicine chapter can be used across settings (hospital inpatient or ambulatory care in hospital or community) but must not be used for reporting cause of death. When coding in primary care, disorders and patterns may not be fully developed so that it may be more feasible to identify reason for encounter rather than main condition and associated conditions.

General principles:

- Consult all parts of the patient record including discharge summary, history, physical examination, investigations, laboratory data, treatments and final diagnoses.
- Coding should relate to reasons for treatment during this episode and need not describe the whole patient’s lifetime history unless a past condition affects current care.
- Be as specific and explicit as possible, using codes to represent aetiology, pathology and manifestations of TM condition.
- Use codes from relevant chapters of the ICD to match the clinical disorders noted on the patient record.
- Code threatened TM conditions (i.e. those not well defined or not manifest).

The inclusion of the supplementary chapter on Traditional Medicine conditions in ICD-11 aims to foster integration of TM into the health system. Hence, it is recommended that - wherever possible - TM1 codes should be used in conjunction with those from other ICD-11 chapters (Chapter 01-25) to enable comparison of Western medicine diagnosis and Traditional Medicine diagnosis.

The following generic coding scheme and alternative coding options can be used:

1. Read the patient summary and medical record.
2. Select WM diagnosis/diagnoses, TM1 disorder(s) (TM1), and/or pattern(s) (TM1) to be coded.

<b>Options</b>	<b>Examples</b>	<b>ICD-11 Coding Examples</b>
a. WM diagnosis alone	Asthma	<a href="#">CA23.32</a>
b. WM diagnosis with TM1 pattern	Asthma	<a href="#">CA23.32</a>
	Turbid phlegm accumulation in the lung pattern (TM1)	<a href="#">SF86</a>
c. WM diagnosis with TM1 disorder	Asthma	<a href="#">CA23.32</a>
	Wheezing disorder (TM1)	<a href="#">SF81</a>

You may choose more than one disorder (TM1) and more than one pattern (TM1) from the TM chapter.

3. Consult the electronic Coding Tool or relevant Alphabetic Indexes for WM and TM1 entries
4. Go to tabular list for the relevant code. Take note of inclusions and exclusion notes and textual descriptions.
5. Assign the appropriate code and follow any specific guidelines for that code.

Applying the above listed generic coding scheme and alternative coding options for a given clinical picture must take into account the regulatory context, coding practice and setting specific requirements at country level. Additional coding conventions may be developed in response to country specific information needs (e.g. coding of main condition, use of

extension codes, coding of neoplasms and injury, chronic and complicated conditions, sub-clinical or constitutional complaints, external cause of injury and adverse reaction).

## 2.24 General statistical recommendations

### 2.24.1 Data quality

To ensure high quality, processes for monitoring the quality of the coded data need to be implemented. This is referred to as Quality Assurance. On the following pages you will find some suggestions relating to the application of Quality Assurance for mortality and morbidity statistics. As a basic principle, those responsible for the collection and analysis of data should be involved in the development of the protocols for the processing and coding of the data, and in determination of the other data items to be cross-tabulated with them. Collecting quality data requires a clearly designed workflow (from reporting to coding to analysis), and adequate training of all involved parties. In particular, all participants need to understand the process and their part in it. The basic stages of the workflow include:

1. Documentation – This is where the information starts. Identifying a condition and then documenting it on a death certificate, in a medical record or on another medical form need to be carried out completely and accurately, using the best possible evidence. For this reason, this part of the workflow, should generally be carried out by a well-trained physician.
2. Reporting – Documented information should be reported in the format specified by the responsible agencies. There may be differences in the required reporting structure, timeframe and obligations, depending on the country and/or data collection circumstances.
3. Verification– Where unclear information, incomplete or illogical statements are reported, a feedback loop and return of queries to the certifiers and documenters should be used.
4. Grouping and analysis – Both serve to aggregate data in ways that are determined by the diverse use cases. Rules and constraints should be clearly understood and communicated when analysis is undertaken and results are reported and used.

### 2.24.2 Specificity versus ill-defined codes

Reported information should be coded to the highest level of detail possible. In some instances, the details available are sparse, incompletely documented or only trivial details are reported. Though the ICD provides categories for these cases, such non-specific information does not allow understanding of epidemiological patterns and/or utilisation of health systems nor does it support prevention of disease.

### 2.24.3 Problems of a small population

Population size is one of the factors that need to be considered when the health status of a population is assessed by means of mortality or morbidity data. In countries with small populations, the annual numbers of events in many categories will be very small and may fluctuate from year to year, especially when disaggregated by recommended age and sex. These problems can be alleviated through one or more of the following measures:

- use or presentation of broad groupings of ICD rubrics, such as chapters
- aggregation of data over a longer time period, e.g. to take the preceding two years of data together with those for the current year and produce a 'moving average' figure
- using the broadest possible age groupings

The recommendations that apply for small national populations also hold true, in general, for reporting the data relating to subnational segments of larger populations. Investigations of health issues in population subgroups have to take into consideration the effect of the size of each of the subgroups on the type of analysis used. This need is generally recognised when dealing with sample surveys, but often overlooked when the investigation concerns the health problems of special groups in a national population.

#### 2.24.4 'Empty cells' and cells with low frequencies

Regardless of the list of causes being used, it may be found that no cases for one or more listed cause(s) occur in certain cells in a statistical table. Where there are many empty lines in a table, it is worth considering the omission of such lines from a published table. When only the occasional case of a disease occurs in a country, the line can be regularly omitted from the published statistical table and a footnote added to indicate either that there were no cases in the reported timeframe or, when sporadic cases do occur, in which cell the case would have appeared. For cells with very low frequencies, especially those relating to diseases that would not be expected to occur, it is important to establish that the cases existed and did not result from a coding or processing error. This should be carried out as part of the general quality control of the data.

#### 2.24.5 Precautions needed when tabulation lists include subtotals

It may not always be apparent to those processing the data that some of the items in the tabulation lists are in fact subtotals or earlier reported categories. These items may include titles of blocks and titles of four-character categories or the items for chapter titles (in the condensed versions of the mortality tabulation lists). These entries should be ignored when totals are calculated, otherwise cases may be counted more than once.

#### 2.24.6 Ethical Aspects

Confidentiality refers to the obligation to not disclose information (data to third parties where that information has originally been delivered in confidence. This duty was codified in the Hippocratic Oath in the 4th century BCE and is still one of the core principles of medical ethics. Any information that might allow the identification of a specific person should only be viewed by people who are authorised to do so. Authorisation means that a person is legally permitted to access the information. e.g. medical staff, coroners and coders are all people who may be authorised to see sensitive information.

Generally, the only way for confidential information to become publicly accessible is through legislation, statutes and regulations. Sometimes confidential information can become public record after a certain period of time. For instance, in some regions of the world the passage of time can render death certificates matters of public record and, therefore, the requirement for them to remain confidential no longer applies.

The authorised supplier of confidential information must verify that the requesting person is an authorised user and determine their level of authorisation. The supplier must be aware of the level of information that can be made available to the authorised user and take appropriate steps to guard against unauthorised disclosure. The authorised user must not attempt to gain access to information which they are not authorised to obtain. Additionally, the user must also guard against unauthorised access to the information that has been supplied to them. This means that users must secure the confidential information and any recordings of that information in a way that prevents unauthorised access. The information must only be used for appropriate purposes and must be returned as required. National legal frameworks, state and local regulations, and institutional guidelines provide specific rules and information regarding how to maintain confidentiality.

#### 2.24.7 Avoidance of Potential Harm

Direct and serious harm can result from a breach of confidentiality. For example, the disclosure of sensitive information can potentially lead to stigma and discrimination against an individual. Conversely, greater harm can result from maintaining confidentiality than from not doing so. Some circumstances may require a judgement that involves balancing the harms to or disclosure against the interests of, the patient, deceased person and other relevant parties. A person may suffer 'harm' physically, socially or psychologically as a result of a breach of confidentiality. A confidential diagnosis that is breached makes the patient lose faith or trust in the clinician, and the patient may then suffer abuse from another person or suffer the stigma associated with certain conditions. In other circumstances the nondisclosure of one person's confidential information may result in another individual or a community being at risk of developing a harmful condition or being exposed to a harmful situation.

This is a difficult concept and one that must be approached in a thoughtful way. As previously mentioned, there are times when it is justifiable to give others confidential information, such as when reporting communicable disease incidence. In such cases the reporting of confidential information is usually allowed. This is an example of where the nondisclosure of a disease could result in major harm to others.

If it is necessary to disclose information, it is preferable to contact the relevant person and let them know about the need to do so. In some cases, this may not be possible or appropriate, and users should be guided by legal and institutional guidelines. The harms that can be caused by disclosure of certain information must be considered. Some information that can be particularly sensitive includes tests for genetic disorders and diseases, incidence of communicable diseases, and HIV test results. Sometimes there are special requests for confidentiality that may require increased levels of confidentiality assurances. These special requests cannot supersede legal requirements for disclosure but should be respected when possible.

#### 2.24.8 Security of Privacy – Confidentiality

Privacy relates to protecting an individual's control over what personal information and decisions may or may not be shared with others. For instance, when a physician examines or speaks with a patient it is usually done in a non-public area so that the information given to the physician by the patient cannot be heard by anyone else. It also enables the physician to

give a patient their diagnosis in private. Data are shared with consent by the patient or where required by law or legislation. Security of privacy and confidentiality of health (and other) data are usually addressed by national laws and regulations.

## 2.25 Recommendations in relation to statistical tables for international comparison

The following recommendations aim to standardise the presentation of coded data to allow national and international comparisons between different countries or regions.

### 2.25.1 The recommended Special tabulation lists

There are standard ways of listing causes coded according to the ICD, and there are formal recommendations concerning lists for tabulation that allow for national and international comparisons. The hierarchical structure of the ICD allows considerable flexibility for other possible tabulations. For mortality, the ICD includes special tabulation lists which are intended for circumstances in which the four-character list is too detailed, and are designed so that international comparison of significant diseases and groups of diseases is not compromised by different groupings used in different countries.

It should be noted that the special tabulation lists are designed for the aggregation and reporting of coded data. They are not for coding purposes.

The special tabulation lists are:

- List 1 Mortality tabulation list
- List 2 Morbidity tabulation list
- List 3 International Shortlist for Hospital Morbidity Tabulation (ISHMT)
- List 4 Infectious diseases by agent condensed list
- List 5 Sustainable Development Goals (SDGs)
- List 6 WHO Verbal autopsy list

The mortality list is based on the codes assigned for the underlying cause of death.

Morbidity list do not include codes from traditional medicine conditions.

#### **Use of prefixes to identify the special tabulation lists**

Use of the numerical prefixes prevents confusion between the special tabulation lists, as the ICD four-character codes have a letter in the second position. Where an adapted list is used for national or sub-national purposes, an alternative identifying prefix should be used.

#### **The special tabulation list for mortality**

The mortality tabulation list provides items for each ICD chapter and also, within most chapters, identify the items with residual items entitled 'Remainder of...' that complete the coverage of the respective chapter. The list covers the full range of ICD four-character codes applicable for mortality, required for reporting and publication purposes.

#### **Locally designed lists for mortality**

For most countries, the mortality tabulation list provides enough information on the most important diseases and external causes of death. They also facilitate comparison over time and observation of shifts in the relative frequencies as health programmes take effect, of e.g. infectious diseases and degenerative diseases. It permits comparison between sub-national areas and population sub-groups. In addition, it makes meaningful international comparisons of causes of death possible.

Lists similar to the special tabulation list can also be designed for local use. The ICD rubrics in such lists can be selected and grouped in any way. Special lists may be needed, for example, for monitoring progress, in terms of mortality and also morbidity, of many local health programmes. When adapting the special tabulation lists to national requirements, or when a tabulation list is being devised for a new or special project, a trial run is helpful by counting the number of cases for each four-character category. In such way, it can be determined which conditions are appropriate for broad grouping, and where subcategories are necessary.

Where a local list is constructed, the key to the condensed categories should contain the same four- (or five-) character codes of the core classification.

### **The special tabulation list for morbidity**

The morbidity special tabulation list is intended as a basis for national lists and for intra- and inter-country comparison. National lists can be constructed by either condensing or expanding the core classification as appropriate. The list is suitable for data on inpatient care and, with suitable adaptation (notably through aggregation of some items and expansion of items relating to Chapter 21 'Symptoms, signs or clinical findings, not elsewhere classified' and Chapter 24 'Factors influencing health status and contact with health services') for information from other sources, such as ambulatory care and surveys.

When a local list is constructed, the key to the condensed categories should contain the four (or five) character codes of the core classification. The list has been designed for international comparisons of hospital morbidity statistics. This concise list allows for comparison of hospital activity, independent of health systems. The conditions have been selected in a way that they can always be treated in an admission of at least 24 hours. If, after examination of the frequencies of the ICD four-character rubrics, it is necessary to expand the list, some of the items within ICD categories can be subdivided according to the core classification or even to the five-character level. If the recommended list is too detailed or if a shorter list is required, selection can be made based on national or local health concerns. Depending on a country's 'epidemiological profile', categories may be combined to shorten the list.

### **2.25.2 International morbidity reporting**

International morbidity reporting and comparison of data among different countries requires internationally agreed definitions of:



- inpatient, recoding of day-patients, outpatient
- hospital
- treatment episode
- reason for encounter used instead of diagnosis

See Section [1.4](#) for more detail.

### 2.25.2.1 Minimum data set and markup for postcoordination

A minimum data set suitable for international comparison would include age, sex, main diagnosis, (reason for admission after assessment at the end of the stay), and health sector (hospital, practitioner, other), is ideally accompanied by the definitions in place for the variables mentioned above, and the main intervention. In an extended data set, ideally, additional diagnoses and interventions are reported in separate data fields. The markup for international reporting of postcoordinated codes in clusters will follow the specifications below:

- a slash '/' separates 2 stem codes
- an '&' links stem codes with extension codes
- a cluster may consist of a single code or One condition with additional detail in one cluster
- stem code & extension code & extension code

Two unrelated conditions will have two clusters:

- stem code - stem code

Two clusters with multiple codes:

- stem code & extension code/stem code & extension code & extension code

Example 1:

Diabetes mellitus / Diabetic retinopathy

Example 2:

Multiple fractures of forearm / fracture of shaft of ulna & compound fracture / fracture of shaft of radius & compound fracture /external cause code

### 2.25.3 Presentation of statistical tables

The degree of detail in cross-classification by cause, sex, age, and geographical area will depend both on the purpose and range of the statistical reportings and on the practical limits to their tabulation. The following patterns, which are designed to promote international compatibility, present standard ways of expressing various characteristics. Where a different classification is used in published tables (e.g. in age-grouping) it should be reducible to one of the recommended groupings.

- (a) Analysis by the International Classification of Diseases should, as appropriate, be in accordance with:

- the detailed list of four-character categories, with or without five or six-character subcategories;
  - the special tabulation list for mortality;
  - the special tabulation list for morbidity.
- (b) Age classification for general purposes:
- under 1 year, 1 to 4 years, 5-year groups from 5 to 84 years, 85 years and over, 95 years and over;
  - under 1 year, 1-4 years, 5-14 years, 15-24 years, 25-34 years, 35-44 years, 45-54 years, 55-64 years, 65-74 years, 75 years and over.
  - under 1 year, 1-14 years, 15-44 years, 45-64 years, 65 years and over.
- (c) Classification by area should, as appropriate, be in accordance with:
- each major civil division;
  - each town or conurbation of 1,000,000 population and over, otherwise the largest town with a population of at least 100,000;
  - a national aggregate of urban areas of 100,000 population and over;
  - a national aggregate of urban areas of less than 100,000 population;
  - a national aggregate of rural areas.

**Note 1.** Statistics relating to (c) should include the definitions used to determine urban and rural.

**Note 2.** In countries where medical certification of the cause of death is incomplete or limited to certain areas, figures for deaths not medically certified should be published separately.

### 2.25.3.1 Tabulation of causes of death

Statistics of causes of death for a defined area should be in accordance with recommendation 'Statistical tables' (a)(1) above, or, if this is not possible, with recommendation 'Statistical tables' (a)(2).

Deaths should preferably be classified by sex and age group as in recommendation 'Statistical tables' (b)(3).

Statistics of causes of deaths for the areas in recommendation 'Statistical tables' (c) should comply with recommendation 'Statistical tables' (a)(2), or if this is not possible, with recommendation 'Statistical tables' (a)(3). They should preferably be tabulated by sex and age group as in recommendation 'Statistical tables' (b)(2).

### 2.25.3.2 Injury mortality

Injury mortality traditionally distinguishes between injuries that are caused by:

- Interpersonal violence and sexual abuse
- Collective violence including wars, civil insurrections and riots
- Traffic incidents
- Incidents at home, at work, and while participating in sports and other recreational activities

In the context of mortality, the WHO recommends the retention of codes for both main injury and external causes. In places where this is not feasible, the external cause code should be retained. For injury-related deaths, in ICD-11 the external cause code is the single underlying cause of death code, and incorporates the intent, mechanism, and object of the deceased in a single code. Place of occurrence and activity are coded separately.

#### 2.25.4 Standards and reporting requirements for mortality in perinatal and neonatal periods

##### 2.25.4.1 Terms used in perinatal and neonatal mortality

**The perinatal period** commences at 22 completed weeks of gestation and ends 7 completed days after birth, i.e. includes days 0 – 6 after birth.

**The neonatal period** commences at birth and ends 28 completed days after birth i.e. includes days 0 – 27 after birth.

**Gestational age** is the duration of gestation estimated based on the best obstetric estimate of gestation, which is usually expressed in completed weeks with additional days, or in completed days.

**The best obstetric estimate of gestation** is based on the birth attendant's final estimate of gestation, calculated from time elapsed since the first day of gestation. The first day of gestation is usually determined by:

- 1) the first day of the last menstrual period (LMP) if confirmed by results of early ultrasound scan
- 2) by early ultrasound scan, where LMP and results of early ultrasound scan differ
- 3) by LMP and/or the clinical postnatal estimate of gestational age, where no early ultrasound scan is available.

In cases of assisted reproduction when the date of embryo transfer is known, an offset of 14 days is to be added for calculating gestational age.

Gestational age is counted by calendar days where day zero (Day 0) is used to refer to the first calendar day of gestation and day 1 for the second calendar day. The first day of gestation i.e. day 0 corresponds to gestational age 'zero completed weeks' with zero additional days (gestational age 0+0 completed weeks), and 6 days later would be gestational age 0+6 completed weeks.

The number of completed weeks is calculated as the number of days since the first day of gestation divided by 7, presented as a whole integer plus a remainder. For example, day 8 after gestation is 1+1 completed weeks, and day 252 corresponds to 36+0 completed weeks, and 6 days later (258 days) would be 36+6.

**Birthweight** is the first weight of the fetus or neonate obtained after birth. For live births, birthweight should preferably be measured within the first hour of life before significant postnatal weight loss has occurred.

**Chronological age** used in recording deaths in the neonatal period is counted as follows: Day 0 is used to refer to the first 24 hours after birth. Day 1, is the remainder of the 2nd calendar day (date of death=date of birth+1) but outside the 1st 24 hours. Day 2 is the 3rd calendar day (date of death=date of birth+2).

Where it is not feasible to capture information on hours at death, Day 0 should be considered to be the calendar day of birth (date of birth is equal to date of death), and subsequently: Day of death = Date of death - date of birth.

#### 2.25.4.2 Definitions in perinatal and neonatal mortality

##### *Fetal death, spontaneous abortion, stillbirth, live birth, neonatal death*

Death in perinatal or neonatal period should be counted based on the time of delivery (i.e. a complete expulsion or extraction from a woman), though it may be diagnosed earlier in utero. Delivery of an embryo or fetus may occur either spontaneously, assisted or by caesarean section (i.e. it includes deliberate interruption of an ongoing pregnancy by medical or surgical means intended to result in a live birth), while it should be distinguished clearly from induced abortion.

- **Fetal death** is death of a fetus prior to its complete expulsion or extraction from a woman, irrespective of the duration of pregnancy.
- **Spontaneous abortion** (also referred to as **miscarriage**) is a spontaneous loss of pregnancy (i.e. embryo or fetus) before 22 completed weeks of gestation.
- **Stillbirth** is the complete expulsion or extraction from a woman of a fetus, following its death prior to the complete expulsion or extraction, at 22 or more completed weeks of gestation.
- **Live birth** is the complete expulsion or extraction from a woman of a fetus, irrespective of the duration of the pregnancy, which, after such separation, shows signs of life.
- **Neonatal death** is a death after live birth which occurs during the neonatal period.

Death of an embryo or fetus may be diagnosed in utero by absence of heart sounds, confirmed by imaging techniques where available, or after the complete expulsion or extraction from a woman by absence of signs of life. Signs of life at birth include breathing, beating of the heart, pulsation of the umbilical cord and definite movement of voluntary muscles whether or not the umbilical cord has been cut or the placenta is attached. Fleeting reflex activity observed only in the first minute after birth does not warrant classification as a sign of life.

Notes for national and international reporting (See also [2.25.4.5](#)):

- Definitions and reporting criteria concerning the lower limit for fetal deaths or spontaneous abortions may differ depending on different national legislation

(generally medically recognised embryonic period of gestation lasts until the 12th completed week, however another national legal limit could be set at fetus of for example 11 or 13 weeks). Any lower limit should be specified in the statistics produced.

- It is recommended to produce statistics for all fetal deaths and all deaths following live births, while reporting criteria may differ depending on different national legislation.
- For international reporting it is recommended to report stillbirths of 28 or more completed weeks of gestation (late stillbirth) and all deaths following live birth. Countries with ability for reporting stillbirths of 22 or more completed weeks of gestation (early stillbirth) are recommended to do so.
- When information on gestational age is unavailable for spontaneous abortion or stillbirth, use birthweight less than 500 grams as the criteria.

#### *Artificial termination of pregnancy*

- **Artificial termination of pregnancy** is a complete expulsion or extraction from a woman of an embryo or a fetus (irrespective of the duration of the pregnancy), following a deliberate interruption of an ongoing pregnancy by medical or surgical means, which is not intended to result in a live birth.

Artificial termination of an ongoing pregnancy is regulated by law and may be referred to as either legal abortion, induced abortion, fetal reduction or other terminologies. As long as it meets the definition of artificial termination of pregnancy it should be considered separately from spontaneous abortion or stillbirth and clearly distinguishable in the statistics.

Whilst transient signs of life may be evident after some cases of artificial termination of pregnancy at later gestational weeks, these should never be coded as spontaneous abortion or live births.

### 2.25.4.3 Other terminologies used in recording and presentation of perinatal or neonatal mortality

*Fetal death (i.e. regardless of gestational age; lower limit, if any, should be stated)*

- **Antepartum fetal death** is a fetal death before the onset of labour. If vital status of the fetus at the onset of labour is unknown, consider it was antepartum if there is presence of signs of maceration at the time of delivery.
- **Intrapartum fetal death** is a fetal death during labour. If vital status of the fetus at the onset of labour is unknown, consider it was intrapartum if there is fresh skin appearance or no signs of maceration at the time of delivery.

*Stillbirth (i.e. 22 or more completed weeks)*

- **Early stillbirth** is stillbirth of 22-27 completed weeks of gestation.
- **Late stillbirth** is stillbirth of 28 or more completed weeks of gestation.
- **Antepartum stillbirth** is stillbirth following antepartum fetal death (i.e. occurring before onset of labour).
- **Intrapartum stillbirth** is stillbirth following intrapartum fetal death (i.e. occurring during labour).
- **Macerated stillbirth** is stillbirth with presence of signs of maceration at the time of delivery.
- **Fresh stillbirth** is stillbirth with fresh skin appearance and no signs of maceration at the time of delivery.

*Period of gestation*

- **Preterm** is less than 37 completed weeks (less than 259 days) of gestation.
- **Term** is from 37 completed weeks to less than 42 completed weeks (259 to 293 days) of gestation.
- **Post-term** is 42 completed weeks or more (294 days or more) of gestation.

*Birthweight*

- **Extremely low birthweight** is a birthweight less than 1000 g (up to and including 999 g).
- **Very low birthweight** is a birthweight less than 1500 g (up to and including 1499 g).
- **Low birthweight** is a birthweight less than 2500 g (up to and including 2499 g).
- **Large birthweight** is a birthweight of 4000 g or more and less than 4500 g (up to and including 4499 g).
- **Exceptionally large birthweight** is a birthweight of 4500 g or more.

*Neonatal death*

- **An early neonatal death** is a death during the first 7 completed days after live birth (days 0 - 6)
- **A neonatal death** is a death during the first 28 completed days after live birth (days 0-27)

*Total birth*

- **Total birth** is the total of stillbirth and live birth. If the lower limit of stillbirth is set different from 22 weeks, for example at 28 weeks for international reporting, this should be clearly stated.

#### 2.25.4.4 Certification of stillbirth and live births in the neonatal period

The reliability of the mortality estimates related to children depends on accuracy and completeness of recording and reporting of births and deaths. A death certificate should be issued for all fetal deaths regardless of its occurrence being spontaneous or deliberate, and for all neonatal deaths following live births.

Under-reporting and misclassification are common, especially for stillbirths and early neonatal deaths. Countries should arrange registration and reporting procedures so that the events and the criteria for their inclusion in the statistics can be easily identified.

Data of fetal deaths meeting requirements for stillbirth registration should be included in mortality statistics, but should be clearly distinguishable from neonatal deaths following live births. Follow instructions in [2.25.4.5](#) for details, when it is not clear whether the certificate relates to a stillbirth or a neonatal death following live birth.

Artificial termination of pregnancy should also be included in mortality statistics, but should be clearly distinguishable from spontaneous abortion or stillbirths.

#### *The international form of medical certificate of cause of death and additional details*

With the update of the International form of medical certificate of cause of death in 2016, just one certificate is used for all cases including stillbirths (see [2.15](#)). Care needs to be taken to correctly fill in the specific section for perinatal deaths on the certificate. The previously recommended perinatal death certificate should be replaced by the form in [2.15](#), and perinatal deaths should be coded according to the general mortality coding instructions.

While not required for ICD-11 coding, the additional information mentioned in [2.15](#) might be helpful for the monitoring of perinatal and infant deaths of a country or region.

#### *Level of details for recording*

Gestational age and birthweight should be recorded for all live births and stillbirths to the degree of accuracy to which it is measured.

The gestational age should be recorded in number of completed weeks as a minimum, and where possible an additional variable capturing the number of days should also be included.

While statistical tabulations include 500 g groupings for birthweight, weights should not be recorded in those groupings. The actual weight should be recorded to the degree of accuracy to which it is measured.

Chronological age at death during the first 24 hours of life (day 0) should be recorded in units of completed minutes or hours of life. For the second (day 1), third (day 2) and through 27 completed days of life, age at death should be recorded in days. It is recommended that these data are collected as part of a minimal perinatal dataset.

#### 2.25.4.5 Reporting criteria for fetal death, stillbirth and live birth

As a minimum all stillbirths and deaths following live births born with 22 or more completed weeks of gestation ( $\geq 154$  days) should be included in the statistics, though the legal requirements for the registration may vary depending on different national legislations.

When information on gestational age is not available, the corresponding criteria for birthweight (500g or more) should be used.

Where gestational age and birthweight are not known, for example when only crown-heel length or estimated gestational age based on physical examination is available, or when no such information is available, the event should be included in, rather than excluded from, mortality statistics of the perinatal period.

Where fetal deaths and/or neonatal deaths at <22 completed weeks of gestation (or <500g) are included in perinatal statistics these should be presented separately from stillbirths and/or neonatal deaths at 22 or more completed weeks of gestation and the lower limit for inclusion in perinatal statistics in the setting should be stated, for example '20 completed weeks of gestation' or 'no lower gestational age limit'.

Note that the reporting criteria above do not apply to artificial termination of pregnancy, which is defined irrespective of duration of pregnancy and should be presented separately from fetal death, stillbirth or live birth.

#### *Criteria for international reporting*

In statistics for international comparison, inclusion of fetal deaths and live births born at extremely low gestational ages disrupts the validity of comparisons and is not recommended. Therefore, the criteria for international reporting of stillbirths and/or neonatal deaths are set at 28 completed weeks or more, while countries are encouraged to provide, where possible, data from 22 completed weeks or more as well.

#### **Table 1**



<b>Gestational age (completed weeks)</b>	<b>Birthweight (grams)</b>	<b>Recommendations for registration of data</b>
<22 (very early gestation)	<500	Only required for neonatal mortality national statistics. When used for spontaneous abortion (miscarriages), should be reported separately from perinatal statistics and the lower gestational age limit for data collection stated.
22-27 (early gestation)	500 or more	For national statistics, and for international statistics of countries with ability for reporting of early gestation deaths (stillbirths and neonatal mortality)
28 or more (late gestation)	1000 or more	For international statistics (stillbirths and neonatal mortality)
Unknown gestational age	Unknown birthweight	Include in statistics only when there is a high likelihood that the stillbirth or neonatal death occurred at the given criteria e.g. 28 or more weeks for international statistics.

#### 2.25.4.6 Statistical presentation of perinatal, neonatal, infant or under-five mortality

For perinatal mortality statistics, full-scale multiple- cause analysis of all conditions reported will be of the greatest value.

Countries should provide the rates listed below for international comparisons:

- **Late stillbirth rate** = (stillbirths  $\geq$  28 weeks gestation/total births (stillbirths  $\geq$  28 weeks gestation and live births) x 1000
- **Early neonatal mortality rate** = (early neonatal deaths (day 0-6)  $\geq$  28 weeks gestation /live births  $\geq$  28 weeks gestation) x 1000
- **Perinatal mortality rate** = (stillbirths  $\geq$  28 weeks gestation and early neonatal deaths (day 0-6)  $\geq$  28 weeks gestation) /total births (stillbirths  $\geq$  28 weeks gestation and live births) x 1000

#### *Groupings of gestational age groups for fetal death under 22 weeks, stillbirth and neonatal mortality statistics*

<22 completed weeks (<154 days) N.B. where the under 22 week category is used, the lower limit included should be specified

22 - 27 completed weeks (154 - <196 days)

28 - 31 completed weeks (196 - 223 days)

32 - 36 completed weeks (224 - 258 days)

37 - 41 completed weeks (259 - 293 days)

42 completed weeks and over (294 days and over)

### *Groupings of birthweight for fetal death under 22 weeks, stillbirth and neonatal mortality statistics*

By weight intervals of 500 grams, i.e. 1000-1499 grams, etc.

499 grams or less 500 – 999 grams 1000 - 1499 grams 1500 - 1999 grams 2000 - 2499 grams  
2500 - 2999 grams 3000 - 3499 grams 3500 - 3999 grams 4000 - 4499 grams 4500 - 4999  
grams 5000 grams or more

### *Groupings by chronological age in neonatal mortality statistics*

- *Preferred groupings:*  
By single days for the first week of life (under 24 hours (day 0), 1, 2, 3, 4, 5, 6 days), 7-13 days, 14- 20 days, 21-27 days
- *Alternatives if preferred groupings is not available:*  
Under 24 hours, 1-6 days, 7-27 days,  
Under 7 days, 7-27 days
- *Additional chronological age groupings for day 0 neonatal deaths:*  
Under 1 hour, 1–11 hours, 12–23 hours

#### **2.25.4.7 Under-five mortality**

Under-5 mortality (Under-5 mortality rate – probability of dying between birth and exactly 5 years of age, expressed per 1,000 live births.) is a leading indicator of the level of child health, quality of life, health infrastructure, and overall development in countries. It is also the SDG indicator.

#### **2.25.4.8 Infant mortality**

Infant mortality (infant mortality rate – probability of dying between birth and exactly 1 year of age, expressed per 1,000 live births) is an indicator for quality of life and health infrastructure.

#### **2.25.5 Standards and reporting requirements related for maternal mortality**

Maternal mortality is part of the assessment of the Sustainable Development Goals (SDG) that serve to monitor the impact of the joint work of the international community in this field.

##### **2.25.5.1 Maternal death**

A maternal death is defined as the death of a woman while pregnant or within 42 days of termination of pregnancy, irrespective of the duration and site of the pregnancy, from any cause related to or aggravated by the pregnancy or its management, but not from accidental or incidental causes.

##### **2.25.5.2 Late Maternal death**

A late maternal death is defined as: the death of a woman from direct or indirect obstetric causes, more than 42 days but less than one year after termination of pregnancy.

### **2.25.5.3 Comprehensive maternal death**

A grouping that combines maternal death and late maternal death.

### **2.25.5.4 Direct and indirect obstetric deaths**

Maternal deaths, late maternal deaths, and comprehensive maternal deaths are subdivided into two groups:

- Direct obstetric deaths: those resulting from obstetric complications of the pregnant state (pregnancy, labour, and puerperium), and from interventions, omissions, incorrect treatment, or from a chain of events resulting from any of the above.
- Indirect obstetric deaths: those resulting from previously existing disease or disease that developed during pregnancy, and that were not due to direct obstetric causes but were aggravated by the physiologic effects of pregnancy.

### **2.25.5.5 Death occurring during pregnancy, childbirth and puerperium**

A death occurring during pregnancy, childbirth, and puerperium is defined as: the death of a woman while pregnant or within 42 days of termination of pregnancy, irrespective of the cause of death (direct and indirect obstetric and non-obstetric death).

### **2.25.5.6 Recording requirements of maternal mortality**

In order to improve the quality of maternal mortality data and provide alternative methods of collecting data on deaths during pregnancy or related to pregnancy, as well as to encourage the recording of deaths from obstetric causes occurring more than 42 days following termination of pregnancy, the Forty-third World Health Assembly in 1990 adopted the recommendation that countries consider including questions regarding current pregnancy and pregnancy within one year preceding death on death certificates.

The classification also allows the recording of deaths that occur one year or more after termination of the pregnancy ([JB62](#) Death from sequelae of obstetric causes).

### **2.25.5.7 International reporting of maternal mortality**

For the purpose of international reporting of maternal mortality, only those maternal deaths occurring before the end of the 42-day reference period should be included in the calculation of the various ratios and rates, although the recording of later deaths is useful for national analytical purposes.

### **2.25.5.8 Numerator, denominator, and ratios of published maternal mortality**

Published maternal mortality ratios should always specify the numerator, which can be given as the number of recorded direct obstetric deaths, or the number of recorded obstetric deaths (direct plus indirect). Note that cases not coded to Chapter 18 should also be included in the numerator. These include those categories presented in the 'Exclusion Note' at the beginning of Chapter 18, provided that they have been aggravated by pregnancy or conversely aggravated the pregnancy.

The denominator used for calculating maternal mortality should be specified as either the number of live births or the number of total births (live births plus fetal deaths). Where both denominators are available, a calculation should be published for each.

Results should be expressed as a ratio of the numerator over the denominator, multiplied by k (where k may be 1000, 10,000 or 100,000, as preferred and indicated by the country). Maternal mortality ratios and rates can thus be expressed as follows:

1. Maternal mortality ratio:  $(\text{Maternal deaths}/\text{Live births or total births}) \times k$
2. Direct obstetric mortality ratio:  $(\text{Direct obstetric death only}/\text{Live births or total births}) \times k$
3. Ratio for death occurring during pregnancy, childbirth and puerperium:  $(\text{Deaths occurring during pregnancy, childbirth and puerperium}/\text{Live births}) \times k$

### **3 Part 3 - New in ICD-11**

#### **3.1 ICD-11 new conventions and terminology**

**Table 1:** *Major changes from ICD-10 to ICD-11, including rationale*

## ICD-10

### Coding Scheme

Chapter numbering is roman numerals  
Three-character categories, each of which can be further divided into up to 10 four-character subcategories.

Alphanumeric code with a letter in the first position and a number in the second, third and fourth positions. The fourth character follows a decimal point.

The first character of a code is a letter and does not relate to the chapter number. The letter may have been the same for two short chapters (e.g. Chapter VII (H00-H5) and Chapter VIII (H60-H95)), or two letters may have been used for one long chapter (e.g. Chapter XIX (S00-T98)).

Residual category identified by numeric character .8 and unspecified category identified by numeric character .9.

Code cluster concept does not exist in ICD-10.

### Terminology

a range of expressions are used to describe a causal relationship between conditions in a code title

## ICD-11

Chapter numbering is Arabic

Stem code (category) is four characters and there are two levels of subcategories

An alphanumeric code with a letter in the second position and number in the third character position to differentiate from the codes of ICD-10. The inclusion of a forced number at the third character position prevents spelling 'undesirable words'. A letter in the second character position allows for clear distinction between a code from ICD-11 and one from ICD-10. Alphanumeric codes cover the range from 1A00.00 to ZZ9Z.ZZ. Codes starting with an 'X' indicate an extension code (see Extension code chapter). The letters 'O' and 'I' are omitted to prevent confusion with the numbers '0' and '1'.

The first character of the code always relates to the chapter. A first character of 1-9 is used for chapters 01 through 09 and for chapters 10 through 26, the first character is a letter. The code range of a single chapter always has the same character in the first position. For example, [1A00](#) is a code in chapter 01, and [BA00](#) is a code in chapter 11.

The terminal letter 'Y' is reserved for the residual category 'other specified' and the terminal letter 'Z' is reserved for the residual category 'unspecified'.

ICD-11 supports postcoordination and the linking codes within a code cluster.

The preferred term is 'due to' for categories where two conditions are mentioned and causal sequence exists. Other terms, such as 'caused by'; or 'attributed to' may be allowed synonyms. The phrase 'secondary to' is equivalent and may also be included as a synonym.

**ICD-10**

a range of expressions indicating the concurrence of two conditions in a code title (e.g. 'in' or 'with').

**ICD-11**

The preferred term is 'associated with' for categories where two conditions are mentioned and there is no causal sequence implied.

**Dagger-Asterisk system and additional sub-classifications**

	<b>ICD-10</b>	<b>ICD-11</b>
<b>Dagger asterisk system</b>	ICD-10 (and ICD-9) used the dagger asterisk system to describe the aetiological condition for primary tabulation (dagger code) and the clinical manifestation, relevant site and or other aspects (asterisk code). In addition, there were sets of codes to be used to add more detail (e.g. B95-B97) or lists of sub-classifications to add anatomical detail to categories.	The ICD-11 equivalents of asterisk codes (i.e. codes for manifestations) and other codes that served to add detail, may be found in Chapter 21 'Symptoms, signs or clinical findings, not elsewhere classified', the Chapter X 'Extension codes' chapter or in a body system chapter as appropriate. The extension codes include chapter groups anatomy, agents, histopathology and other aspects that may be used to add detail to a code.
<b>Use of multiple codes for one condition/additional sub-classifications</b>	More than one category could be used to specify more detail for another category. For example, infectious agents (B95-B97) or the asterisk codes.	Postcoordination - The use of multiple codes (i.e. stem codes and/or extension codes) together to fully describe a documented clinical concept.
<b>'Code also' instruction'</b>	'Use additional code, if desired, to identify' notes were present to suggest optional coding.	'Code also' instructions inform about additional information that needs to be coded in conjunction with certain categories, because that additional information is relevant for primary tabulation

The dagger and asterisk system has been removed in ICD-11, but the functionality of coding the aetiology and manifestation remains. A number of former asterisk codes that were previously used to identify manifestations of diseases are now listed in Chapter 21 'Symptoms, signs, or clinical findings, not elsewhere classified'. A portion of former asterisk codes also reside in the corresponding body system chapter. Asterisk codes that were repetitions of the dagger code were removed. Lists for coding optional anatomical detail have been grouped into one section in Chapter X 'Extension codes'.

## Other general differences

### ICD-11

Category description	All ICD-11 categories have a short and a long description. The short description describes the meaning of the category in 100 words or less and appears in the printed version of the classification. The long description is without length restriction, including detailed information that appears in the content model.
Content model	All ICD-11 categories include separate information on anatomy, aetiology and other aspects that can be accessed for search purposes, or when browsing in the tabular list of the ICD-11 MMS.

Special tabulation lists of ICD-10 continue to exist, but there are two additional ones, the Startup Mortality List (SMoL) and the list for verbal autopsy. Additional special tabulations can be derived from the new multiple parenting technique, e.g. all WHO notifiable diseases, listing all conditions that are assigned to the relevant section of the infectious diseases chapter.

For morbidity, the definition of main diagnosis has changed to be 'the reason for admission, after assessment at the end of the stay'. This definition is less prone to interpretation, and countries that had switched from the 'most resource intensive' definition to the 'reason for admission at the end of the stay' using ICD-10, noticed only small changes in their activity statistics.

### 3.1.1 Short Description

The description is a short characterisation (maximum of 100 words) of the entity that states things that are always true about a disease or condition and necessary to understand the scope of the rubric. Descriptions do not contain elements intended for use in level 3 (common epidemiology) or things that may be true for level 4 (clinical criteria). Descriptions were formerly called 'short definitions'. For further information refer to section [3.4The Content Model](#)

### 3.1.2 Additional Information

This is a text field that is not mandatory, but that may contain any additional information about, or characteristics of, the diseases or conditions included in the entity. This text field provides more context for the entity. For example, the most common epidemiologic circumstances, putative or highly suspected aetiological agents, or other information that may not always be true but may be common, typical, or expected. Additional information was formally called 'long definition'.

### 3.1.3 Code Structure

The codes of the ICD-11 are alphanumeric and cover the range from 1A00.00 to ZZ9Z.ZZ. Codes starting with 'X' indicate an extension code (see Extension codes). The inclusion of a forced number at the third character position prevents spelling 'undesirable words'. A letter in the second character position allows for clear distinction between a code from ICD-11 and one from ICD-10. For further information refer to section [1.2.4.1Code structure](#).

## 3.2 Chapter Structure of ICD-11

The international core reference linearisation is the ICD-11 for Mortality and Morbidity Statistics (ICD-11MMS). It is used for coding and reporting illnesses or causes of death for international comparison. The naming of this linearisation highlights its two main use cases. This core linearisation is divided into 28 chapters, of which 25 refer to health conditions similar to past ICD versions, while one serves to identify external causes of morbidity and mortality, and another includes concepts of traditional medicine. Lastly, there are two additional sections for optional additional use, one for extension codes to add more detail for different dimensions of a disease, such as anatomy, mark a condition to be present on admission, or a disease having been relevant in the family history (see Section [Extension Codes]) and the other for functioning assessment to provide a set of codes for assessment and scoring in the ICD using ICF functioning domains of high explanatory power (see Section [3.2.27 Section V – Supplementary section for functioning assessment](#)).

ICD-11 has five new chapters. As a result, the numbering of the chapters has changed. The new chapters are:

- Chapter 03 ‘Diseases of the blood or blood-forming organs’ and Chapter 04 ‘Diseases of the immune system’. Conditions affecting the immune system’ and conditions affecting the blood are now in two separate chapters.
- Chapter 07 ‘Sleep-Wake disorders’. Sleep wake disorders have been regrouped together in this new chapter.
- Chapter 17 ‘Conditions related to sexual health’. Sexual conditions have been grouped together in this new chapter.
- Chapter 26 ‘Supplementary Chapter Traditional Medicine Conditions - Module I’. A chapter for traditional medicine has been added.

The following is an overview of the organisational principles and classification structure (hierarchy) for each of the 26 chapters. The revised structure and new sets of functionalities in ICD-11 were the result of incorporating scientific updates and making the classifications more relevant for computerisation.

### 3.2.1 Chapter 01 – Certain infectious or parasitic diseases

Structure of Chapter 01

#### 3.2.1.1 Chapter 01 – Structure of chapter 01

The chapter first lists infectious disease groupings by clinical syndromes, then groups other infections by mode of transmission, and then lists the remaining infections by their agent. Some conditions of major public health concern are listed at the same level. Variants to the conditions in the chapter that occasionally can occur as localised infections are primarily coded to this chapter. Infections that are primarily localised, and where the agent usually is either unknown, or not relevant, or there is a mixed aetiology, reside in the organ chapters. Frequent infectious agents may be listed as individual child categories under the localised infection. In some instances, infections could equally be located in the infectious disease chapter and in an organ system chapter. In such cases, the decision that creates the least change (ICD-10 legacy) has been chosen. Some grouping is also designed to be able to code



frequently reported imprecise information, as is the case for meningitis and encephalitis and respiratory infections.

A special tabulation list groups the infections by agents and is intended for special tabulation and reporting only.

### **3.2.1.2 Chapter 01 – Rationale for chapter 01**

The purpose of the structure of chapter 01 is to minimise the impact on longitudinal statistics of major infections, to allow reporting of main infections that have a common lead symptom (e.g. diarrhoea) without mention of a specific agent. Influenza, though visibly affecting the respiratory tract, affects multiple parts of the body and is also of important public health concern. For that reason, it has been moved into the infectious chapter. Prion diseases can be transmissible, genetic or arise spontaneously. They are rare conditions that only affect the nervous system. Many are inherited. The presence of a specific gene is a prerequisite to developing a prion disease. In view of these facts, it was decided to keep the prion diseases grouped together and move the whole group to the neurology chapter.

### **3.2.1.3 Antimicrobial resistance**

The ICD parts relating to Antimicrobial Resistance (AMR) have been designed to support the Global Antimicrobial Resistance Surveillance System. Priority pathogens are identified in combinations with currently relevant antimicrobial substances. The section is designed to allow postcoordination of other substance and agent combinations in a cluster. The section on AMR is located in Chapter 21 'Symptoms, signs or clinical findings, not elsewhere classified', so that the underlying disease or agent is always coded in conjunction with the AMR category. ICD and the surveillance system focus on specific tracer pathogen-substance combinations. However, ICD design allows the coding of the full antibiotic susceptibility pattern if desired. For tabulation, the AMR codes should be reported in combination with the infectious disease. Where only one condition can be reported, the infectious disease should be retained. However, at the national level, the set of infectious diseases and the number of AMR cases among the infection cases should be tabulated.

## **3.2.2 Chapter 02 – Neoplasms**

### **3.2.2.1 Chapter 02 – Structure of chapter 02**

The general hierarchy of Chapter 02 consists of the following:

- 1st level - Behaviour
- 2nd level - Broad sites or systems
- 3rd level - Specific site
- 4th level - Morphological (histological) type

There are three groups that are an exception to the above hierarchy. They are:

1. Neoplasms of brain and central nervous system
  - 1st level - Broad sites
  - 2nd level - Behaviour - morphological (histological) type
2. Neoplasms of haematopoietic and lymphoid tissues

1st level - Broad morphological (histological) type

2nd level - Specific morphological (histological) type

3. Malignant mesenchymal neoplasms

1st level - Specific morphological (histological) type

2nd level - Site

### 3.2.2.2 Chapter 02 - Rationale for Chapter 02

The progress in oncology has clearly demonstrated that a site-only based categorisation of malignant and benign tumours provides limited information for prevention, treatment, and prognosis for persons that are affected by a tumour. ICD–10 included a limited number of categories based on histopathology (e.g. some lymphoid neoplasms, melanoma).

In ICD–11, main tumour sites have subdivisions of histopathology first. The groups chosen were based on an analysis of international mortality and morbidity reporting, cancer registries, and clinical reporting. The redesigned sections were reviewed for missing details in relation to the ICD use cases.

Keeping the main anatomical axes intact allows backwards compatibility. However, the structure was adjusted in a few places to match anatomical subdivisions of the TNM classification (<https://www.uicc.org/resources/tnm>).

For tumours of the central nervous system, the histological and behavioural distinction between benign and malignant is a grey area. As such, it was decided to move all central nervous system tumours outside the basic framework of behaviour and group them together.

The field of genetic markers is rapidly changing. Whereas for some tumours, such markers have been used for many years, for others, this is not the case. As such, with the exception of haematological tumours, genetic markers were not included, and have not been used for the classification. They are, however, included in Chapter X ‘Extension codes’, and can be added as postcoordination to the relevant code from the neoplasms chapter to describe the relevant tumour entity fully.

### 3.2.3 Chapter 03 – Diseases of the blood or blood-forming organs

#### 3.2.3.1 Chapter 03 – Structure of chapter 03

This new chapter (previously part of Chapter III in ICD-10) has three main sections:

- Anaemias or other erythrocyte disorders
- Coagulation defects, purpura or other haemorrhagic or related conditions
- Diseases of spleen

Neoplasms of haematopoietic and lymphoid tissues are primarily located in Chapter 02 ‘Neoplasms’ while Symptoms, signs or clinical findings of blood or blood-forming organs or the immune system are primarily located in Chapter 21.

**The first two major sections comprise of the following hierarchy:**

- 1st level - Anaemias and coagulation disorders
- 2nd level - Broad category of disease/disorder type
- 3rd level - Congenital vs acquired
- 4th level - Further specificity of disease/disorder type

**The third major section comprises of the following hierarchy:**

- 1st level - Diseases of spleen
- 2nd level - Congenital vs acquired
- 3rd level - Specific disease/disorder type

### **3.2.3.2 Chapter 03 – Rationale for chapter 03**

For Chapter 03, there has been a reorganisation of the chapter into a clinical view of diseases of the blood, an aetiological view of diseases of the blood and diseases of the spleen. Anaemias are now all under one group with a separate group for ‘Coagulation defects, purpura or other haemorrhagic correlated conditions’.

### **3.2.4 Chapter 04 – Diseases of the immune system**

#### **3.2.4.1 Chapter 04 – Structure of chapter 04**

This new chapter (previously part of Chapter III in ICD-10) has the following sections:

Immunodeficiencies

Non-organic specific systemic disorders

- 1st level - Being the main groupings above
- 2nd level - Broad category of disease/disorder type
- 3rd level - Specific disease/disorder type
- 4th level - Further specificity of disease/disorder type

- 1st level - Autoinflammatory disorders
- 2nd level - Specific syndrome

- 1st level - Allergic or hypersensitivity conditions
- 2nd level - Broad category for body systems

- 1st level - Certain diseases involving the immune system
- 2nd level - Specific disease/disorder type
- 3rd level - Further specificity of disease/disorder type

Diseases of thymus

- 2nd level - Specific disease/disorder type

#### **3.2.4.2 Chapter 04 – Rationale for chapter 04**

For Chapter 04, there are new sections for immune disorders that differ from the section previously located in Chapter III of ICD-10. For the immune system they are classified mainly by clinical syndrome, and in an alternate view the immune system conditions are shown by

cell line. A section for Allergic or hypersensitivity conditions has been included in this chapter. Overall, more detail has been added to the chapter.

### 3.2.5 Chapter 05 – Endocrine, nutritional or metabolic diseases

#### 3.2.5.1 Chapter 05 – Structure of Chapter 05

Chapter 05 has four major sections:

1. Endocrine diseases
  - 2nd level - Specific gland or hormone system
  - 3rd level - Specific diseases/disorder
2. Nutritional disorders
  - 2nd level - Broad categories of diseases/disorder
  - 3rd level - Specific disease/disorder
3. Metabolic disorders
  - 2nd level – Broad categories of diseases/disorder
  - 3rd level - Specific disease/disorder
4. Postprocedural endocrine or metabolic disorders
  - 2nd level - Specific disease/disorder

Neoplasms of the endocrine system are primarily located in Chapter 02 ‘Neoplasms’ and Symptoms, signs or clinical findings of endocrine, nutritional or metabolic diseases are primarily located in Chapter 21.

#### 3.2.5.2 Chapter 05 – Rationale for Chapter 05

There is increased international standardisation of endocrine disease terminology being used to describe the complex nature of endocrine conditions. The intent is to include all dysfunctions that lead to a specific endocrine disorder.

Diabetes mellitus and Intermediate hyperglycaemia have been expanded to reflect current international terminology. The complications often associated with diabetes have continued to be included in the classification in the appropriate body system chapter in line with the various clinical modifications. ‘Code also’ and ‘Use additional code’ notes have been included to link the types of diabetes and the various complications to enable the addition of codes for further specificity.

Sources of change for this section were based on the current WHO Classification of Diabetes Mellitus and Intermediate Hyperglycaemia 2011 and the Department of Chronic Diseases, Health Promotion, WHO.

The WHO Department of Nutrition for Health and Development proposed changes to the section on Nutritional Disorders with advice from the Nutrition Guidance Expert Advisory Group (NUGAG) for updates to this section of the classification. Metabolic disorders are now

aetiologically based and have been classified into three distinct areas; ‘Inborn errors of metabolism’, ‘Disorders of metabolite absorption and transport’ and ‘Disorders of fluid, electrolyte and acid-base balance’ following clinical advice received from the relevant international societies for metabolic diseases.

### 3.2.6 Chapter 06 – Mental, behavioural or neurodevelopmental disorders

#### 3.2.6.1 Chapter 06 – Structure of Chapter 06

The hierarchy of Chapter 06 consists of:

1st level - Broad category of disease/disorder type

2nd level - Specific disease/disorder type

3rd level - Further specificity of disease/disorder type

#### 3.2.6.2 Chapter 06 – Rationale for Chapter 06

The overall linear structure of the proposed Mental, behavioural or neurodevelopmental disorders chapter for ICD–11 has been a topic of substantive and comprehensive discussions by the Topic Disorders Advisory Group for Mental Health, as well as extensive interactions with the American Psychiatric Association in relation to the just-published Fifth Edition of the Diagnostic and Statistical Manual of Mental Disorders (DSM-5) (1), from the time of the Advisory Group’s initial appointment in 2007.

The appropriate architecture of a diagnostic classification of mental and behavioural disorders is an issue that has received substantial attention over the course of the revision (e.g. 2-4). One of the guiding principles of the ICD–11 is that it should reflect current scientific evidence regarding the relationships among disorders (5) rather than antiquated concepts such as ‘neurosis’, which have poor construct and predictive validity. In addition, a major goal of the WHO Department of Mental Health and Substance Abuse for the current revision is to improve the clinical utility of this part of the ICD–11 (6, 7). Because the ICD–11 uses a different coding structure that is not based on a decimal numbering system, such that a larger number of blocks or groupings can be accommodated within the chapter, an important opportunity was presented to bring the classification more in line with current research and clinical practice in terms of how groupings of disorders are represented.

Three streams of work provide the rationale and evidence for the linear structure of Mental and Behavioural Disorders in the ICD–11.

#### **Evidence Reviews by Working Groups for ICD–11 Mental, behavioural or neurodevelopmental disorders**

The first stream of work relates to the outcome of evidence reviews by the 14 Working Groups reporting to the Advisory Group, each of which had multiple face-to-face meetings over at least a 2-year period. The Working Groups were asked to review the available scientific evidence and other information about the clinical application of classifications in various settings throughout the world, and to provide evidence and a rationale for its groupings as well as the content and arrangement of categories within them. This work resulted in manuscripts describing the rationale for most groupings of disorders that have been published in or submitted to peer-reviewed journals (e.g. 8-15). Space does not permit detailing the rationale and evidence base for each structural change here, but this

information as it relates to any specific decision can be provided on request based on the material generated by the Working Groups.

### **Formative Field Studies on Clinical Utility of the Linear Structure**

The second stream of work relevant to the linear structure of Mental and Behavioural Disorders focused on clinical utility and is represented by two formative field studies undertaken by the WHO and the Field Studies Coordination Group reporting to the Advisory Group (16, 17). The purpose of these studies was to examine the conceptualizations held by mental health professionals around the world of the relationships among mental disorders to inform decisions about the structure of the classification. From a clinical utility perspective, particularly in terms of improving the interface between health information and clinical practice, the most important and desirable features of a classification's organisation is that (a) it helps clinicians find the categories that most accurately describe the patients they encounter as quickly, easily, and intuitively as possible and (b) the diagnostic categories so obtained would provide them with clinically useful information about treatment and management. A mental disorders classification that is difficult and cumbersome to implement in clinical practice and does not provide information that is of immediate value to the clinician has no hope of being implemented accurately at the encounter level in real-world health care settings. In that event, clinical practice will not be guided by the standardisation and operationalization of concepts and categories that are inherent in the classification, and important opportunities for practice improvement and outcomes assessment will be lost. In turn, a diagnostic system that is characterized by poor clinical utility at the encounter level cannot generate data based on those encounters that will be a valid basis for health programs and policies, or for global health statistics. The rationale behind these two studies was that if the ways in which clinicians conceptualized the organisation of mental disorders as encountered in their day-to-day clinical practice was found to be (a) consistent across countries, languages, and disciplines, and (b) distinct from the organisation of ICD-10, then this information could be used to create a classification of mental disorders that corresponds more closely to clinicians' cognitive organisation of categories and would therefore be more intuitive and efficient for use in real-world health care settings.

The first formative field study (17) was an internet-based study administered in both English and Spanish, in which 1,371 psychiatrists and psychologists from 64 countries participated. The second formative field study (16) involved the face-to-face administration of a standardised sorting and hierarchy-formation task to 517 mental health professionals in eight countries and five languages. Both studies found that clinicians' conceptual map of mental disorders was rational and highly stable across profession, language, and country income level. Moreover, both studies found that the proposed structure for mental and behavioural disorders in ICD-11 was more consistent with clinicians' conceptual models than the structure of either ICD-10 or DSM-IV. The second study also clearly demonstrated that clinicians preferred a 'flatter' structure with a larger number of groupings as compared with a more hierarchical structure with fewer groupings as found in ICD-10.

### **Harmonisation with DSM-5**

The third stream of work relates to efforts to harmonise the structure of the ICD-11 chapter on Mental and Behavioural Disorders with the structure of the DSM-5, where possible.

Overall, the high degree of similarity between the overall structure of DSM-5 (1) and the proposed linear structure for ICD–11 Mental and Behavioural Disorders represents a major success of the ICD – DSM harmonisation effort. Relatively minor differences relate primarily to:

1. proposals to combine the classifications of ‘organic’ and ‘non-organic’ aspects of conditions such as sleep disorders and sexual dysfunctions in ICD–11 in separate chapters in ways that are more consistent with current evidence and clinical practice, which was not an option for DSM-5 given that it is by definition a classification of mental disorders; and
2. differences in conventions related to residual categories and mental disorders associated with other underlying disease under ICD–11 from decisions about the organisation of such categories in DSM-5. Additional information about the rationale for the few remaining substantive differences in overall structure between the two classifications is available upon request. It must be emphasized that the resulting similarity in organisation between the two systems is the product of several years of complex negotiations. Given that DSM-5 has already been published, further changes to the ICD–11 structure would almost certainly move ICD–11 in the direction of reduced similarity and harmonisation with DSM-5.

## References

1. American Psychiatric Association (2013). *Diagnostic and statistical manual of mental disorder, Fifth Edition (DSM-5)*. Washington, DC: American Psychiatric Publishing.
2. Andrews, G., Goldberg, D. P., Krueger, R. F., Carpenter, W. T. Jr., Hyman, S. E., Sachdev, P., & Pine, D. S. (2009). Exploring the feasibility of a meta-structure for

- DSM-V and ICD-11: Could it improve utility and validity? *Psychological Medicine*, 39, 1993–2000.
3. Jablensky, A. (2009). A meta-commentary on the proposal for a meta-structure for DSM-V and ICD-11. *Psychological Medicine*, 39, 2099–2103.
  4. Wittchen, H.-U., Beesdo, K., & Gloster, A. T. (2009). A new meta-structure of mental disorders: A helpful step into the future or a harmful step back to the past? *Psychological Medicine*, 39, 2083–2089.
  5. Hyman, S. E. (2010). The diagnosis of mental disorders: The problem of reification. *Annual Review of Clinical Psychology*, 6, 155–179.
  6. Reed, G.M. (2010). Toward ICD-11: Improving the clinical utility of WHO's international classification of mental disorders. *Professional Psychology: Research and Practice*, 41, 457–464.
  7. International Advisory Group for the Revision of ICD-10 Mental and Behavioural Disorders. (2011). A conceptual framework for the revision of the ICD-10 classification of mental and behavioural disorders. *World Psychiatry*, 10, 86–92.
  8. Al-Adawi, S., Baks, B., Bryant-Waugh, R., Claudino, A.M., Hay, P., Monteleone, P., et al. (2013). Revision of ICD- status update on feeding and eating disorders. *Advances in Eating Disorders*, 1, 10-20.
  9. Creed, F., & Gureje, O. (2012). Emerging themes in the revision of the classification of somatoform disorders. *International Review of Psychiatry*, 24, 556-567.
  10. Drescher, J., Cohen-Kettenis, P., & Winter, S. (2012). Minding the body: Situating gender identity diagnoses in the ICD-11. *International Review of Psychiatry*, 24, 568-577.
  11. Gaebel, W. (2012). The status of psychotic disorders in ICD-11. *Schizophrenia Bulletin*, 38, 895-898.
  12. Maercker, A., Brewin, C.R., Bryant, R.A., Cloitre, M., van Ommeren, M., Jones, L.M., et al. (2013). Diagnosis off classification of disorders specifically associated with stress: Proposals for ICD-11. *World Psychiatry*, 12, 198-206.
  13. Maj M., & Reed, G.M. (Eds.) (2012). The ICD-11 classification of mood and anxiety disorders: background and options. *World Psychiatry*, 11(Suppl. 1).
  14. Poznyak, V., Reed, G.M., & Clark, N. (2011). Applying an international public health perspective to proposed changes for DSM-5. *Addiction*, 106, 868-870.
  15. Rutter, M.C. (2011). Research review: Child psychiatric diagnosis and classification: concepts, findings, challenges and potential. *Journal of Child Psychology and Psychiatry*, 52, 647-660.
  16. Reed, G.M., Roberts, M.C., Keeley, J., Hooppell, C., Matsumoto, C., Sharan, P., et al. (2013). Mental health professionals' natural taxonomies of mental disorders: Implications for the clinical utility of the ICD-11 and the DSM-5. *Journal of Clinical Psychology*, 69, 1191-1212.
  17. Roberts, M.C., Reed, G.M., Medina-Mora, M.E., Keeley, J.W., Sharan, P., Johnson, D.K., et al. (2012). A global clinicians' map of mental disorders to improve ICD-11:



Analysing meta-structure to enhance clinical utility. *International Review of Psychiatry*, 24, 578-590.

### 3.2.7 Chapter 07 – Sleep-wake disorders

#### 3.2.7.1 Chapter 07 – Structure of Chapter 07

Chapter 07 is a new chapter in ICD–11. It contains Sleep-wake disorders that were previously located within the respiratory, neurology, or mental health chapters. By combining these disorders into one chapter, more detail can be included for many of the sleep related disorders. The hierarchy consists of:

- 1st level - Broad category of disease/disorder type
- 2nd level - Specific disease/disorder type
- 3rd level - Further specificity of disease/disorder type

#### 3.2.7.2 Chapter 07 – Rationale for Chapter 07

As Sleep-wake disorders pertain to an area of overlap between mental health, neurological disorders and pulmonary conditions, the decision was made to place them together in one chapter.

### 3.2.8 Chapter 08 – Diseases of the nervous system

#### 3.2.8.1 Chapter 08 – Structure of Chapter 08

- 1st level - Mixture of diseases, disorders and sites and combinations of both.
- 2nd level - Subcategory mixture of specific disease or disorder type and sometimes site.

#### 3.2.8.2 Chapter 08 – Rationale for Chapter 08

ICD–11 sees a major overhaul in the organisation of the blocks which make up the neurology chapter. The restrictive decimal coding system of the ICD–10, with its capacity to contain only 11 blocks of disorders per chapter, resulted in blocks containing miscellaneous neurological entities which did not logically fit together, such as the episodic and paroxysmal disorders block, containing headache disorders, epilepsy, transient ischaemic attacks and sleep disorders. The ICD–11 now positions headache disorders, epilepsy and cerebrovascular disorders at a block level, and sleep disorders at chapter level (Chapter 07).

Not only has the structure of the neurological chapter changed, but the approach to classification also integrates current clinical practice and advancements in the understanding of neurological diseases. In the time since the ICD–10 was published, enormous progress in the fields of genetics, molecular biology and medical technologies have been made. An increase in the number of codes is inevitable when one reflects on the recent knowledge gain in neurology, so a balance between comprehensiveness, clinical utility and maintaining a public health approach is the aim. The working groups tackled this issue by considering the more common disorders to appear in the chapter, with less common aetiological variations of these disorders being subject to a ‘double coding’ technique. One major change which illustrates the advancement of knowledge is the addition of a block entitled ‘Paraneoplastic and autoimmune disorders of the nervous system’. This block contains immune-mediated neurological diseases, a field in which

knowledge has exploded in recent years. A second example of how the new version reflects molecular biological advancement is through awarding Prion diseases block status despite their rarity. Previously, they featured as part of the infections of the central nervous system block, but research interest after the major public health issue in Europe in the 1990s has led to new variants of prion diseases being discovered.

The world has seen a large rise in the elderly population since the 1990s. Neurocognitive disorders have been declared as a major public health concern and research into its aetiology and neuropharmacology has boomed. The ICD–11 block on Neurocognitive disorders reflects the better understanding in this area.

One final particularly noteworthy change can be found in the ‘Other disorders of the nervous system’ block. This block is employed to capture the ‘spill over’ from other neurology blocks and those disorders which are deemed unclassifiable elsewhere. In the ICD–10, due to the aforementioned decimal coding system, this block was an incongruent collection of diseases. This block has now reduced significantly in size due to the new, streamlined neurology chapter structure which includes new blocks of disorders previously contained in the ‘other disorders of the nervous system’ section of ICD–10. These include ‘disorders of consciousness’, ‘disorders of cerebrospinal fluid pressure and flow’, ‘disorders of the autonomic nervous system’, ‘nutritional and toxic disorders of the nervous system’ and ‘spinal cord disorders excluding trauma’. Their promotion to block status will hopefully have a positive effect on coding practices.

One complicating issue facing the Neurology Topic Advisory has been the need to cross-link disorders which have a neurological presentation or phenotype to their aetiological roots within other chapters or blocks within the neurology chapter. One of the countless examples of this kind of relationship would be mitochondrial disorders of neuromuscular junction. They must be cross-linked both in the neurology chapter, and in the Endocrine, nutritional or metabolic diseases chapter.

### 3.2.9 Chapter 09 – Diseases of the visual system

#### 3.2.9.1 Chapter 09 – Structure of Chapter 09

The general hierarchy of Chapter 09 consists of the following:

- 1st level - Broad category of anatomy
- 2nd level - Specific anatomy category
- 3rd level - Broad category of disease/disorder type
- 4th level - Further specificity of disease/disorder type

### 3.2.10 Chapter 10 - Diseases of the ear or mastoid process

#### 3.2.10.1 Chapter 10 – Structure of Chapter 10

The general hierarchy of Chapter 10 consists of the following:

- 1st level - Broad category of anatomy
- 2nd level - Specific disease/disorder type
- 3rd level - Further specificity of disease/disorder type

### 3.2.11 Chapter 11 – Diseases of the circulatory system

#### 3.2.11.1 Chapter 11 – Structure of Chapter 11

There are two main hierarchies in Chapter 11.

- 1st level - Broad category of disease/disorder type
- 2nd level - Specific disease/disorder type
- 3rd level - Further specificity of disease/disorder type

OR

- 1st level - Broad category of anatomy
- 2nd level - Specific anatomy type
- 3rd level - Specific disease/disorder type

#### 3.2.11.2 Chapter 11 – Rationale for Chapter 11

There have been large scale changes in clinical practice in cardiovascular diseases and their management since ICD-10 was published over 20 years ago. Changes introduced for ICD-11 in this chapter reflect these changes and the shift in disease profiles and increased survival following procedures. As a consequence, there has been a major expansion in the number of disease entities within ICD-11, with new classification hierarchies and updated nomenclature. For instance, the incidence of heart valve disease is no longer dominated by rheumatic fever in developed societies, although it remains important in developing nations, and consequently there has been a shift in diagnostic paradigms to that of valve type, then valve pathology followed by aetiology.

Many items previously classified in ICD-10 as 'Other forms of heart disease' (I30-I52) have become major clinical issues in today's cardiology, warranting the creation of new distinct higher-level categories. Two examples are:

- Diseases of the myocardium, including extensive subsections on Myocarditis and Cardiomyopathy.
- Cardiac arrhythmia, including a large new subsection on 'Cardiac arrhythmia associated with genetic disorder' and 'Pacemaker or implantable cardioverter or defibrillator or lead dysfunction', both of which are increasingly important areas of clinical practice. The changes in this section have had major input and endorsement from the Paediatric & Congenital Electrophysiology Society and the International Society for Nomenclature of Paediatric and Congenital Heart Disease.

The change in the ICD revision process to be clinically driven has meant that areas primarily managed by non-cardiologists have been relocated to more suitable chapters. Thus, Cerebrovascular diseases have been reclassified to Chapter 08, 'Diseases of the nervous system' and oesophageal varices have been relocated to Diseases of the digestive system (Chapter 13).

A new subsection on Pulmonary Hypertension in the Pulmonary heart disease and diseases of pulmonary circulation section, is based on the resulting paper Updated Clinical Classification of Pulmonary Hypertension, following the 5th World Symposium held in Nice, France, in 2013.

The postprocedural disorders section has been markedly enlarged reflecting increased survival after cardiovascular procedures over the last two decades with recognition of an increasing number of patients with postprocedural morbidities and disease specific complications.

The section on Congenital anomaly of heart and great vessels and related acquired abnormalities classified to Chapter 20 'Developmental anomalies' has been based on the International Paediatric and Congenital Cardiac Code (IPCCC), which has been created over the last decade by the International Society for Nomenclature of Paediatric and Congenital Heart Disease (ISNPCHD, <http://www.ipccc.net>). As a consequence, the 73 congenital cardiology ICD-10 entities in Q20-Q29 have been expanded to 316 diagnoses, as an accurate summation of the heterogeneity of cardiac malformations seen in clinical practice. Reference was also made to the Anatomic and clinical classification of congenital heart defects (ACC-CHD) with the corresponding IPCCC and ICD-10 codes.

### 3.2.12 Chapter 12 – Diseases of the respiratory system

#### 3.2.12.1 Chapter 12 – Structure of Chapter 12

There are two main hierarchies in Chapter 12:

- 1st level - Broad category of disease/disorder type
- 2nd level - Specific disease/disorder type with some anatomy included
- 3rd level - Further specificity of disease/disorder type

OR

- 1st level - Broad category of anatomy
- 2nd level - Specific disease/disorder type
- 3rd level - Further specificity of disease/disorder type

#### 3.2.12.2 Chapter 12 – Rationale for Chapter 12

The changes to Chapter 12 have been made principally to provide current clinical terminology and classification of conditions primarily affecting the respiratory system and have been based on input from international societies and stakeholders. Infectious lung diseases have been moved to Chapter 01 to better reflect the infectious nature of these conditions. Neoplasms of the respiratory system are in Chapter 02 'Neoplasms', and Developmental respiratory diseases are now located in Chapter 20 'Developmental anomalies'.

The grouping 'Upper respiratory tract disorders' contains upper respiratory tract diseases except for conditions that moved to the Infectious disease chapter.

The Lower respiratory tract diseases shifted from the Chronic lower respiratory diseases of the ICD-10, but Chronic obstructive pulmonary disease (COPD) was made an independent category based on an international concept.

Cystic fibrosis has been moved to Certain lower respiratory tract diseases and multiparented to metabolic disorders in the Endocrine chapter because: 'The representative clinical conditions of cystic fibrosis are intractable respiratory infection, end stage

respiratory failure, exocrine pancreatic insufficiency and digestive organ lesions such as the meconium ileus. Cystic fibrosis is a disease due to an abnormality of the Cl ion channel which is CFTR, symptoms of the respiratory symptom is recognised in nearly all cases of patients. The cause of death is mainly respiratory abnormality, and this disease is the target disease of lung transplantation.' This description of cystic fibrosis is found in representative textbooks ('Diseases of the Airways' in the textbook 'Fraser and Pare's Disease of the Chest').

- 'OBSTRUCTIVE DISEASES' in the textbook 'Murray and Nadel's Textbook of Respiratory Medicine'
- 'OBSTRUCTIVE LUNG DISEASES' in the textbook 'Fishman's pulmonary diseases and disorders'
- 'Disease of the Airways' in the textbook 'Fraser and Pare's Disease of the Chest' 'Pulmonary Diseases' in the textbook 'Washington Manual of Medical Therapeutics, The, 34ed.'

The section pertaining to Inhalation, occupational and environmental lung disease has been based on input from the WHO Occupational Health Division.

The Certain specified respiratory diseases principally affecting the lung interstitium shifted from the Other respiratory diseases principally affecting the interstitium. The Idiopathic interstitial pneumonitis was made an independent category based on an international concept and the category of the Primary interstitial lung diseases specific to infancy and childhood was created independently based on the proposal of the Paediatric Topic Advisory Group (TAG).

The section of the Certain diseases of the respiratory system and the section of the Postprocedural respiratory disorders were shifted from Other diseases of the respiratory system of ICD-10 except for the Mediastinal and diaphragm disorders that moved to the section of Pleural, diaphragm and mediastinal disorders.

### 3.2.13 Chapter 13 – Diseases of the digestive system

#### 3.2.13.1 Chapter 13 – Structure of Chapter 13

The general hierarchy of Chapter 13 consists of the following:

1st level - Detailed anatomy

2nd level - Specific disease/disorder type

3rd level - Further specificity of disease/disorder type

#### 3.2.13.2 Chapter 13 – Rationale for Chapter 13

ICD-11 has been improved in structure and content to include diseases and disorders of the orofacial complex. There are several other tissues which as essential components of the orofacial complex, have an important function, and their impairment will have a direct impact on oral health status. It is important to recognise that oral health is more than having healthy teeth; having oral health is being free of chronic oral-facial pain conditions, oral and pharyngeal cancers, oral soft tissue lesions, periodontal (gum) disease, tooth decay and tooth loss and tooth surface loss, birth defects such as cleft lip and palate, and scores of other diseases and disorders that affect the oral, dental, and craniofacial tissues (orofacial

complex) as well as associations with systemic health and disease. This underlines the importance of providing a coherent system for coding and classifying data on orofacial complex diseases and disorders so that the oral health professional can record and collect data from each patient at their clinics, regardless of whether such facility may be part of large hospitals, or small clinics. It is anticipated that being able to record and interpret such data will enable health professionals to contribute to the improvement of oral health as an essential component of general health and will stimulate the use of ICD-11 by oral health personnel.

Major changes have been made to this chapter with very detailed anatomical groups being added to the hierarchy for the digestive tract, according to rostral-caudal order, with the exception of categories for hernia, functional gastrointestinal disorders, and inflammatory bowel diseases.

Functional gastrointestinal disorders are independently described because their pathophysiology is considered from the standpoint of 'Brain-Gut axis', and not only from their impact on the gastrointestinal tract. Inflammatory bowel diseases are also independently described mainly because Crohn's disease involves several organs. In each anatomical group (organ group), aetiology based classifications are used to sub-classify disorders. Particularly, GI disorders are arranged in the following categories:

- A. Acquired anatomical or morphological alterations
- B. Motor disorders
- C. Inflammation including ulcer
- D. Vascular disorders
- E. Non-neoplastic polyps

In addition, there are two other categories listed, although Chapter 13 is not the primary place for these disorders.

- F. Structural developmental anomalies (located in Chapter 20 Developmental anomalies)
- G. Neoplasms (located in Chapter 02 Neoplasms)

Important or common digestive diseases have been allocated their own category, for example gastro-oesophageal reflux disease, columnar metaplastic epithelium, intestinal malabsorption and protein-losing enteropathy, ulcerative colitis, non-alcoholic fatty liver disease and diverticular disease. Polyps are now classified independently, and not in the 'other diseases' section of anatomical site.

Common digestive diseases extending over several organs are classified principally into the disease category of the rostral organ. For example, 'Gastroenteritis' is classified in 'Gastritis', and 'Gastroduodenal ulcer' is classified in 'Gastric ulcer'. The item 'Peptic ulcer, site unspecified' should not be used due to advances in medical technology. It should be classified into either the 'Oesophageal ulcer, Gastric ulcer, Duodenal ulcer or Anastomotic ulcer' category, depending on the disease site.

Vascular disorders of GI organs have been allocated their own category. Oesophageal varices, gastric varices and haemorrhoids are now classified in Chapter 13. In 'Diseases of liver', there are new independent categories including Metabolic and transporter liver disease, Autoimmune liver diseases, Non-alcoholic fatty liver disease and Vascular disorders of the liver.

For the classification of Chronic liver disease with cirrhosis, 'Liver cirrhosis', an item in 'Hepatic fibrosis and cirrhosis', is used. For example, 'Chronic hepatitis B' and 'Liver cirrhosis', 'Chronic hepatitis C' and 'Liver cirrhosis', 'Autoimmune hepatitis' and 'Liver cirrhosis', 'Primary biliary cholangiopathy' and 'Liver cirrhosis', etc. There are new independent sections for 'Diseases of gallbladder and biliary duct' and 'Diseases of pancreas'. Within these new sections, there are new independent categories including Structural developmental anomalies, Congenital anomalies, Acquired anatomical alterations, Cholangitis, Cystic diseases of the pancreas, Chronic pancreatitis and Autoimmune pancreatitis.

### 3.2.14 Chapter 14 – Diseases of the skin

#### 3.2.14.1 Chapter 14 – Structure of Chapter 14

The general hierarchy of Chapter 14 consists of the following:

- 1st level - Broad category of disease/disorder type
- 2nd level - Specific disease/disorder type with some anatomical site
- 3rd level - Further specificity of disease/disorder type

#### 3.2.14.2 Chapter 14 – Rationale for Chapter 14

Major changes have been made to this chapter adding detail coming from the fusion of the American, British, and German dermatological terminologies.

### 3.2.15 Chapter 15 – Diseases of the musculoskeletal system or connective tissue

#### 3.2.15.1 Chapter 15 – Structure of Chapter 15

The general hierarchy of Chapter 15 consists of the following:

- 1st level - Broad category of disease/disorder type
- 2nd level - Specific disease/disorder type with some anatomical site
- 3rd level - Further specificity of disease/disorder type

#### 3.2.15.2 Chapter 15 – Rationale for Chapter 15

The American College of Rheumatology and European League Against Rheumatism (ACR/EULAR) Diagnostic Criteria for Rheumatoid Arthritis (under development) was used to inform the code hierarchy and content model attributes for Rheumatoid arthritis. Current literature informed the change of title of 'systemic connective tissue disorders' to 'non-organ specific systemic autoimmune disorders'. The changes to vasculitis were based on the classification of the Chapel Hill International Consensus Conference on the Nomenclature of Systemic Vasculitis.

The category 'Dermatopolymyositis' was changed to 'Idiopathic inflammatory myopathies' with a change of axes and introduction of further granularity.

The revisions to the classification of spondyloarthritis reflect current expert opinion with comments from Dr Robert Landewé, with a separation of axial and peripheral. Together, the axial and peripheral spondyloarthritis criteria cover the entire spectrum of what was formerly called (undifferentiated) spondyloarthritis and (ankylosing) spondylitis. There is re-arrangement of infective spondyloarthritis, with a secondary axis for the major types of infective process, i.e. bacterial, fungal etc., and supplementary codes to be used for the specific infection.

The new category for Auto-inflammatory syndromes is based on the work of the International Society of Systemic Auto-inflammatory Disease (ISSAID).

### 3.2.16 Chapter 16 – Diseases of the genitourinary system

#### 3.2.16.1 Chapter 16 – Structure of Chapter 16

Chapter 16 has specific sections for Diseases of the female genitourinary system, Diseases of the male genitourinary system, Disorders of breast, Diseases of the urinary system and Postprocedural disorders of the genitourinary system.

The general hierarchy of Chapter 16 consists of the following:

- 1st level - Broad category of body system
- 2nd level - Broad disease/disorder type (with some anatomy)
- 3rd level - Specific disease/disorder type (with some anatomy)

#### 3.2.16.2 Chapter 16 – Rationale for chapter 16

The changes to Chapter 16 are aimed at increasing the clinical utility of the classification by providing a more user-friendly hierarchical structure, increased international comparability and standardisation of genitourinary conditions. This is accomplished by including the most scientifically accurate and internationally agreed-upon terms and definitions provided by various international stakeholders, including the WHO department of Reproductive Health and Research, the International Federation of Gynaecology and Obstetrics (FIGO), National Kidney Foundation and the Kidney Disease International Global Outcomes (KDIGO).

The chapter hierarchy is subdivided into Diseases of the Female Genital System, Diseases of the Male Genital System and Diseases of the Urinary system. This architecture of the female genital system and the male genital system was designed to improve the end-user experience. The female genital system hierarchy is broken down into non-inflammatory and inflammatory disorders, and then further divided by anatomical grouping in the order of gynaecologic (and obstetric) examination (from external to internal genitalia), where applicable. (Vulva, Vagina, Cervix, Uterus, Fallopian Tube, Ovary, Pelvic Cavity).

These groupings have further subdivisions for congenital and acquired abnormalities, as appropriate.

To reflect the current scientific understanding for certain genitourinary conditions, additional detail has been included for the following areas:



Amenorrhea

Ovarian dysfunction

Female pelvic pain

Endometriosis

Adenomyosis

Female infertility

Male infertility

Early pregnancy loss

Pregnancy outcomes

The Kidney failure section of the classification has been revised to reflect the current evidence-based definitions of acute kidney versus chronic kidney disease and the new Kidney Disease ('Improving Global Outcomes (KDIGO) definitions and staging system for acute kidney failure'.)

### 3.2.17 Chapter 17 – Conditions related to sexual health

#### 3.2.17.1 Chapter 17 – Structure of Chapter 17

New chapter in ICD-11 divided into major sections for:

Sexual dysfunctions

Sexual pain disorders

Gender incongruence

1st level - Broad category of condition

2nd level - Specific type of condition

3rd level - Specific disease/disorder

#### 3.2.17.2 Chapter 17 – Rationale for Chapter 17

The chapter has been formulated to group sexually related conditions. This also allows categorisation of gender identity related conditions without stigmatisation, while maintaining recognition of these entities as real conditions so that related health interventions can be accommodated within the health system.

### 3.2.18 Chapter 18 – Pregnancy, childbirth or the puerperium

#### 3.2.18.1 Chapter 18 – Structure of Chapter 18

The general hierarchy of Chapter 18 consists of the following:

1st level - Broad category related to the stages of pregnancy, child birth or the puerperium

2nd level - Specific disease/disorder type

3rd level - Further specificity of disease/disorder type

### **3.2.18.2 Chapter 18 – Rationale for Chapter 18**

The changes to this chapter are intended to increase the clinical utility of the classification by providing a more user-friendly hierarchical structure. Increasing the international comparability and standardisation of conditions related to pregnancy, childbirth and the puerperium by including the most scientifically accurate and internationally agreed-upon terms and definitions provided by various international stakeholders, such as the WHO department of RHR, International Federation of Gynaecology and Obstetrics (FIGO), was also a highly important aspect of the modifications. Particular attention was given to correct integration of concepts and definitions of the International Committee Monitoring Assisted Reproductive Technologies (ICMART).

The changes reflect the current understanding for certain conditions related to pregnancy, childbirth and the puerperium. Additional specifications have been included for Early pregnancy loss

### **3.2.19 Chapter 19 – Certain conditions originating in the perinatal period**

#### **3.2.19.1 Chapter 19 – Structure of Chapter 19**

The general hierarchy of Chapter 19 consists of the following:

- 1st level - Broad category disease/disorder type and some anatomy
- 2nd level - Specific disease/disorder type
- 3rd level - Further specificity of disease/disorder type

### **3.2.20 Chapter 20 – Developmental anomalies**

#### **3.2.20.1 Chapter 20 – Structure of Chapter 20**

Chapter 20 has undergone a major restructure with it now having four major sections

Structural developmental anomalies primarily affecting one body system

- 1st level - Broad category of anatomy
- 2nd level - Specific disease/disorder type
- 3rd level - Further specificity of disease/disorder type

Multiple developmental anomalies or syndromes

- 1st level - Broad category of anatomy
- 2nd level - Specific disease/disorder type
- 3rd level - Further specificity of disease/disorder type

Chromosomal anomalies, excluding gene mutations

- 1st level - Specific disease/disorder type
- 2nd level - Further specificity of disease/disorder type

Conditions with disorders of intellectual development as a relevant clinical feature

- 1st level - Non-syndromic vs syndromic conditions
- 2nd level - Further specificity of disease/disorder type

### 3.2.20.2 Chapter 20 – Rationale for Chapter 20

The ICD–10 classification of developmental anomalies is covered by Chapter XVII: Q00-Q99 Congenital malformations, deformations and chromosomal abnormalities.

It is a very heterogeneous chapter, including malformations, genetic syndromes (with or without malformations) and chromosomal anomalies. This leads to confusion between the genetic origin of a disease and malformation. Therefore, all genetic syndromes without structural developmental anomalies are excluded from this chapter and are reallocated to appropriate chapters of the ICD-11, according to the affected body system(s).

**The new chapter 20 has three main divisions:**

- Structural developmental anomalies/malformations
- Multiple developmental anomalies and syndromes
- Chromosomal anomalies and genetic defects

The first division ‘Structural developmental anomalies/malformations’ includes isolated conditions affecting only one body system. It is organised in sections corresponding to those body systems, which are also classified in the other relevant chapters of ICD–11.

The second division ‘Multiple developmental anomalies and syndromes’ includes conditions affecting several locations within one body system, or several body systems simultaneously. Syndromes which can be said to affect one body system predominantly are assigned to corresponding sections within this division. Syndromes which affect several body systems, without one clearly predominating, are put together in a specific section at the end of the division. There is also a section for Dysplasia syndromes due to inborn errors of metabolism, all of them primarily classified in the chapter for metabolic diseases.

The third division ‘Chromosomal anomalies and genetic defects’ departs from the clinical approach generally followed in the ICD and classifies developmental anomalies defined genetically or cytogenetically, since there is no clear-cut distinction between genetics and cytogenetics. We have started to include specific deletions and duplications corresponding to a clear phenotype, knowing that many more will be described in the coming years. Future ones will be added whenever necessary, during the post-publication revisions of the ICD–11.

A special problem is how to deal with diseases historically defined clinically but including a chromosomal/genetic anomaly as aetiology. In some cases, there are several aetiologies for the clinical entity, and not all of them are chromosomal anomalies: for instance, Silver-Russell syndrome can be caused by a 11p15 duplication, a 7p11.2p13 duplication, but also by maternal uniparental disomy of chromosome 7 or 11 and imprinting defects of 11p15. In other cases, there is an overwhelming correspondence between the clinical entity and a cytogenetic aetiology: for instance, Williams-Beuren syndrome corresponds to the 7q11.23 deletion.

Polyhierarchy is used in a restricted way within the frame of this chapter: once a disease is assigned to a section, it is generally not secondarily classified elsewhere in the chapter. The structure would otherwise become too intricate. On the other hand, all entities in this chapter are to be classified in other chapters of ICD–11, when appropriate.

### 3.2.21 Chapter 21 – Symptoms, signs or clinical findings, not elsewhere classified

#### 3.2.21.1 Chapter 21 – Structure of Chapter 21

Chapter 21 is divided into major sections based on body systems. Each of these sections has the following categories, as appropriate:

- Symptoms and signs
- Clinical findings

An additional section is located at the end of this chapter for ill-defined and unknown causes of mortality.

#### 3.2.21.2 Chapter 21 – Rationale for Chapter 21

The different chapters of ICD–10 included several clinical manifestation categories, some of them as asterisk codes. In order to simplify the structure, improve the use of postcoordination, and also to remove ‘ill-defined’ conditions from organ chapters, several former asterisk codes, additional detail for diverse conditions, and the said ill-defined conditions have been moved here. All follow the main organisation by anatomy, and the anatomical groupings have a secondary parent to the relevant organ chapter, improving the user guidance.

### 3.2.22 Chapter 22 – Injury, poisoning or certain other consequences of external causes

#### 3.2.22.1 Chapter 22 – Structure of Chapter 22

The general hierarchy of Chapter 22 consists of the following:

- 1st level - Broad category of anatomy (e.g. head; hip & thigh)
- 2nd level - Broad category of injury type (e.g. fracture; open wound)
- 3rd level - Further specification

OR

- 1st level - Broad category of cause of injury
- 2nd level - Specific injury type
- 3rd level - Further specificity of injury type

#### 3.2.22.2 Chapter 22 – Rationale for Chapter 22

The principles of the revision were:

- Maintain good back-compatibility with ICD–10, particularly by minimising change at the former three-character level. Change at the former four-character level is more extensive but has also been done with this principle in mind.
- Take account of the extensions to this chapter in clinical modifications of ICD–10 because:

- They are evidence of extensions required to serve clinical purposes in identified situations.
- It is preferable to minimise incompatibilities with these classifications.
- Take account of classifications other than ICD that are in wide clinical use for conditions in scope for this chapter.
- Take account of advice, solicited and proffered.
  - Increased attention to distinctions pertinent to treatment choices and to outcomes, including disability.

These include allowing identification of clinically and prognostically important aspects of fractures (notably whether they extend into a joint) and organ/vessel injuries (degree). Some conditions are much more important when bilateral, and in such instances side has been proposed as precoordinated entities (e.g. injury of the eyes). The United States' clinical modification of ICD-10 (ICD-10-CM) was particularly valuable in this regard, as its injury chapter makes many distinctions, beyond ICD-10, which follow or are consistent with credible and widely used clinical classifications relevant to injury treatment and outcome.

Increased attention has been given to injury conditions specific to childhood (e.g. greenstick and epiphyseal fractures) and to injury conditions that are indicative of possible intentional injury (e.g. posterior rib fractures, 'bucket-handle' and 'corner' fractures).

The work was done with the awareness that this chapter is not primarily used to code the Underlying Cause of Death.

The morbidity use case is particularly important for this chapter.

### 3.2.23 Chapter 23 – External causes of morbidity or mortality

#### 3.2.23.1 Chapter 23 – Structure of Chapter 23

The general hierarchy of Chapter 23 consists of the following sections:

1st level - Intent of external cause (unintentional, intentional self-harm, assault, undetermined intent and intent pending.)

2nd level - Broad category of the mechanism of the external cause

3rd level - More specific mechanism and objects/substances involved in causing injury

4th level - Further characterisation of the external cause

Other sections include Exposure to extreme forces, Maltreatment, Legal intervention, Armed conflict and Causes of health care related harm.

#### 3.2.23.2 Chapter 23 – Rationale for Chapter 23

The main aim of the changes was to provide a more uniform coding structure while still maintaining high compatibility with ICD-10. The changes to the traffic injury categories are aimed at simplifying code selection, while the section on Operations of war and armed conflicts has been revised to capture the more current situations of armed conflicts.

Another enhancement has been to produce a single, hierarchical list of noxious substances to serve the Injury and External Causes chapters.

All mechanisms/objects codable for all intents:

- More uniform code structure
- Revised 'Intent' dimension (N.B. Intent pending; ISH: suicidal/non-suicidal)
- Retain transport codes, but expand vehicle types
- Expanded Place of Occurrence codes
- Expanded and revised Activity dimension (N.B. work-relatedness)
- Revision of Complications of Medical & Surgical Care
- Expanded Legal/War Codes
- Improved provision for maltreatment syndromes
- Introduction of additional dimensions (optional)
- Revision of External Cause index, rules and guidelines
- Provide for Mortality, Morbidity, Lower Resource Settings, Research

Progress has been made on all of these points, though constrained in some respects, particularly for the mortality use-case (due to the tight constraints on code-space combined with the lack of provision for postcoordination/cluster-coding). A section on limitations is at the end of these notes.

Notes provided here focus on several of these points; additional material will be provided on other aspects on request. Comments are also provided here on the two main issues that involve both the External Causes chapter and the Injury chapter (both also involve Chapter X 'Extension codes'): substances; complications of care (Safety & Quality).

## **Transport**

Four dimensions are implicit in the ICD–10 range V01-V89: injured person's mode of transport (e.g. motorcycle), whether the injurious event occurred in road traffic (if so, the resulting injury is a road injury), the injured person's role (e.g. passenger), and what other type of vehicle was involved, if any (counterpart). All four dimensions are required for a revised structure that is conceptually equivalent to the ICD–10 'transport accidents' module at four- character level.

All four dimensions have been precoordinated in the Unintentional transport injury module. This produces a structure with high back-compatibility with ICD–10 at four-character level. It preserves all top-level modes of transport categories (some now split) and the four conceptual dimensions (mode; and for land transport modes: whether in traffic, transport user role and counterpart).

In recognition of code-space limitations, and of the fact that most transport injury cases are unintentional, precoordination of transport cases in the other main intent blocks (intentional self-harm, assault, undetermined intent, and intent pending) is limited to intent by mode of transportation. However, the other dimensions are available for optional use.

The revised transport block includes changes made to resolve problems identified with the ICD– 10 transport section.

- Split several modes of transport to enable identification of important and emerging types that cannot be identified in ICD–10.
- Refined and revised terms and definitions (for clarity, to fill gaps in the set provided in ICD–10 and to improve comparability with terms used internationally for road safety).
- Various other revisions (e.g. of types of vessel in water transport section). Note that the coordination order has been altered from the equivalent in ICD–10, from: mode, counterpart, then user role and traffic status combined to: mode, traffic status, user role, counterpart.

The main reason for this change was to simplify the selection of ‘traffic accident’ categories, which are frequently required when reporting road injury.

### **War and armed conflict**

A revised classification is provided for inclusion as the expansion of intent category Armed conflict (Operations of war in ICD–10). The classification largely follows the expansion of Y36 in the United States’ clinical modification of ICD–10 (ICD–10-CM). This follows the four-character categories in ICD–10 and provides subdivisions, which follow inclusion notes given in ICD–10. In addition, sub-categories are provided to distinguish whether the injured person was military or civilian.

The rubric has been altered by the addition of ‘...and armed conflict’ to ‘Operations of war’, and the inclusion term has been altered accordingly. ‘War’ and ‘civil insurrection’ (which also formed part of the inclusion term) were not defined in ICD–10. The use of a term broader than ‘war’ is considered desirable because war, in the sense of formally declared armed conflicts between nation states (or subnational entities) has become uncommon. Armed conflicts of a range of types and intensities, while tending to become less common, remain much more numerous than wars. Restriction of use of this category to declared wars, and/or to armed conflicts that meet a commonly used criterion of intensity (1,000 or more battle-related deaths in a calendar year = war) was thought to be unduly restrictive. The alternative proposed here is to also include injuries due to ‘Minor’ armed conflicts, defined as those resulting in 25 to < 1,000 battle-related deaths in a calendar year. Application of the definition is aided by the existence of a publicly accessible database listing conflicts found to satisfy it.

### **Crossover issues**

These are matters that affect both the injury and the external causes chapters, and other parts of the ICD.

### **Toxic effects of substances**

Toxic effects of noxious substances appear in ICD–10 at several points, in the Injury and External Causes chapters, and in other chapters. Code lists at those points differ in specificity and are not completely consistent. A design aim for ICD–11 is to produce a single, hierarchical list of noxious substances to serve all of the purposes required for the Injury and External Causes chapters. The benefits of this are: external source(s) can define-by-example the inclusions of the ICD–11 list; and if the external source(s) are actively updated, then this provides a way for the ICD–11 coverage of substances to remain current.

The term 'Harmful effects' is used for all types of harm resulting from harmful chemical effects of substances of all types. It is recognised that other terms, such as 'toxic effect', 'poisoning', 'chemical corrosion' and 'envenomation' are sometimes used in the context of particular substances. These terms will be included as synonyms and subordinate terms where in common use. A number of sources were consulted, including ICECI Objects & Substances dimension; Anatomical Therapeutic Chemical (ATC) classification; TAG-IEG advisory groups on drugs and poisons; Quality and safety TAG; SNOMED; IPCS INTOX.

**The list has two main hierarchical levels.**

The first, with 16 categories, is conceptually related to the code-list that is present in ICD–10 at X40-X49 (Accidental poisoning by and exposure to noxious substances) and the equivalent points in the Intentional Self-harm and Undetermined intent code-blocks. The list results from application of these principles:

- It should have only a few categories. This is necessary for practicability, especially in the context of cause of death coding and because the block structure of the external causes chapter has the effect that each additional category adds several rows.
- The categories should refer to substances or classes of substances that are important causes of mortality or morbidity.
- As many as possible of the categories should be sufficiently specific so meaningful as reporting groups. (By comparison, several categories in the ICD–10 blocks such as X40-X49 are so broad as to be difficult to interpret).
- The several main contexts of exposure were kept in mind when specifying categories (i.e. recreational/street use; clinical use; self-harm; industrial and other exposures).

The 16 categories, either alone or combined with others, allow backwards comparability with eight of the ten categories in ICD–10 X40-X49 (and the equivalent groups in the ISH and Undetermined intent blocks). The only exceptions are two residual groups: '...other gases and vapours' and '...other and unspecified chemicals and noxious substances'. The second level provides categories (n=381), with about the same number and specificity of substances that are provided for in the injury and external causes chapters of ICD–10. It includes all of the categories of substances that are specified in the 'Cause of harm' component of the Quality and Safety TAG classification.

Some categories have been added: to allow for pharmacological innovation and changes in drug use (e.g. synthetic cannabinoids); to reflect additions to ICD–10 made in its clinical modifications (e.g. more specificity concerning anticoagulants); to allow more specific identification of prominent drugs (e.g. paracetamol); to provide for additional widely-used recreational drugs (e.g. Cathinone, the main active agent in khat); and on advice from other TAGs (e.g. types of substance added by the Safety and Quality TAG). We anticipate that more categories will be added in future updates, to reflect changes in drug availability and use.

A more comprehensive list of substances (a superset of the hierarchical list), with synonyms for many of the entries, will be provided in Chapter X 'Extension codes'. That list shares the same hierarchical structure as the precoordinated codes. It also takes account of the ICD–11 Supplementary Classification of Contact Allergens prepared by the Dermatology TAG.



Entries in the Extension codes substances list will be specified in terms of equivalent terms in SNOMED-CT.

### **Complications of care (Quality and Safety)**

This section briefly describes the model for coding complications of care that has been developed by the Quality and Safety Topic Advisory Group (TAG).

The model has three parts, each of which must be coded. The postcoordinated codes for all the parts must be designated as belonging to a cluster. The three concepts are:

1. The resultant injury or harm;
2. The cause of harm; and
3. The 'Mode/Mechanism' of harm. Classifications and code-sets have been developed for (2) and (3) by the Quality and safety TAG. The categories have been entered into the External Causes chapter. The resultant harm (1) is to be coded by using the most appropriate disease or injury code from any part of ICD–11.

The construct would, in principle, fit well into ICD–11 as follows:

1. Resultant injury or harm. Code selected from anywhere in ICD–11.
2. The cause or 'Mode' of harm: Code selected from the relevant block in External Causes chapter
3. 'Mode/Mechanism' of harm

Sanctioning rules lead coders to the subset of 'Mode' codes that are relevant, given the selected 'Cause' (e.g. if 'Cause' is a drug, then the relevant 'Modes' are categories such as overdose and underdose).

### **3.2.24 Chapter 24 – Factors influencing health status or contact with health services**

This chapter should not be used for international comparison or for primary mortality coding.

#### **3.2.24.1 Chapter 24 – Structure of Chapter 24**

This chapter has two major sections: - Reasons for contact with the health service - Factors influencing health status

The general hierarchy of Chapter 24 consists of the following axis:

- 1st level - Broad category of a particular health status or service
- 2nd level - Specific condition

#### **3.2.24.2 Chapter 24 – Rationale for Chapter 24**

Initially, the Functioning Topic Advisory Group for ICD–11 (fTAG) was tasked with the review of the Factors Chapter. They were to evaluate the necessity of each of the 801 codes and propose a revised hierarchical structure for the essential content that would remain. This content was to be both clinically relevant and use-friendly as well as allowing the necessary space for expansion using the extension codes, as necessary. fTAG organised a review that identified the major 'types' of codes as 'diagnostic', 'interventional', 'contextual factors' and

'other/debatable'. This review was combined with the general structure of the ICPC2 classification section on 'social problems' and a new organisation was designed that combined the ICPC2 hierarchy with the ICD-11 codes. For the ICD-11 MMS, a shoreline exercise was then undertaken on the new structure to decrease granularity seen as unnecessary.

### 3.2.25 Chapter 25 – Codes for special purposes

#### 3.2.25.1 Chapter 25 – Structure of Chapter 25

This chapter consists of two blocks:

- International provisional assignment of new diseases of uncertain aetiology, containing the international emergency codes
- National provisional assignment of new diseases of uncertain aetiology, containing codes for use by individual countries

### 3.2.26 Chapter 26 - Supplementary Chapter Traditional Medicine Conditions - Module 1

'Traditional Medicine Module 1' (TM1) chapter is a new supplementary chapter for optional use in ICD, and as such is referred to as the 'TM1 chapter'. The rationale for its inclusion in ICD-11 is to enable Traditional Medicine health services and encounters to count and be counted nationally and internationally. The Module in this chapter in its current form refers to disorders and patterns which originated in ancient Chinese Medicine and developed throughout history to incorporate contemporary science and technology. These disorders and patterns are commonly used in China, Japan, Korea, United States of America, Australia, Europe and elsewhere around the world. The classification rubrics represent a unified set of harmonised Traditional Medicine disorders and patterns from national classifications from China, Japan and Korea. Future Modules may be developed for other forms of Traditional Medicine practices.

#### **Scope:**

This chapter has currently been designed for morbidity recording and reporting. It must not be used for mortality coding and reporting.

#### **Content and structure:**

The content and structure of the TM1 Chapter represent a common language developed jointly through the international cooperation of Traditional Medicine clinicians, researchers, academics and classification experts to enable international comparability of practice and reporting of morbidity in Traditional Medicine. Standardisation of this TM1 classification will allow clinical documentation in different countries to incorporate the same concepts and enable coders and users to extract comparable morbidity data from that documentation. Coders must also be guided by rules which reflect the clinical diagnostic decision-making process. However, the rules are relatively flexible to allow for national adaptations and research questions concerning relationships between diseases, disorders and patterns to be framed from a number of different angles.

The English terms do not necessarily represent the most common translation of the TM terms in Chinese, Korean or Japanese. Where the best fit English TM translation resulted in the same term as used in Western Medicine, it was necessary to indicate a difference

between the Western Medicine (WM) concept and TM concept where the same term had different definitions in TM and WM. This difference in definition is indicated by the use of (TM1) for disorders and patterns throughout the TM chapter.

### Terminology:

The Supplementary Chapter Traditional Medicine Conditions, Module 1, uses the terms disorder and pattern to describe concepts. This is different from the concept descriptions in the Western Medicine chapters which refer to diseases (clinical pictures) and syndromes (clinical presentations). The TM1 chapter is divided into separate sections for disorder and pattern to emphasise the independence of these concepts.

### Definitions

**A disorder** in traditional medicine (disorder (TM1)) refers to a set of dysfunctions in any body system which is judged from associated signs, symptoms or findings. Each disorder (TM1) may be defined by its symptomatology, aetiological explanation based on traditional medicine, course and outcome, treatment response or linkage to interacting environmental factors. A disorder (TM1) is a clinical picture that is relatively stable and reflects the local pathology and related specific manifestations commonly found in the anatomy and function of the affected individuals.

**A pattern** in traditional medicine (pattern (TM1)) refers to the manifestation of the patient's health condition at a given moment in time including all findings which may include:

- *Symptomatology*: pattern of specific and non-specific signs, symptoms or unique findings by traditional medicine diagnostic methods, including the taking of the pulse, examination of the tongue, abdominal examination and other methods that reflect the systemic response of the patient in a dysfunctional condition.
- *Constitution*: the characteristics of an individual, including structural and functional characteristics, temperament, ability to adapt to environmental changes, or susceptibility to various health conditions.

A pattern (TM1) is a clinical picture that is relatively temporary, reflects on the systemic response of the patient and combined pattern of specific and non-specific manifestations that usually hold a multifactorial relationship with the local pathology and the constitutional traits of the patient. A pattern may show individual difference even in the individuals affected by the same pathology that may be further analysed by the theoretical frame of Traditional Medicine.

Traditional Medicine disorder and pattern are named after the body structures, causal explanations, properties and severity which present for clinical investigation and diagnosis. TM1 pattern may denote an individually different pattern (TM1) of systemic responses to the WM disease or TM1 disorder. Pattern is a concept unique to TM1 and may be different from TM1 disorder in the following ways:

### Table 1: Characteristics of Traditional Medicine Disorders and Patterns

<b>Distinguishing Feature</b>	<b>Disorder in Traditional Medicine</b>	<b>Pattern in Traditional Medicine</b>
Constant/ Temporary	A <b>clinical picture that is relatively constant</b> throughout the duration of that disorder	A <b>clinical picture that is relatively temporary</b>
Constant Pathology/ Temporary Response	Usually delivers information reflecting the <b>constant pathology</b>	Usually delivers information reflecting the <b>temporary overall manifestation or response of the patient</b>
Specific/ Non-specific	A concept that summarises <b>findings that are specific</b> to the pathologic process under investigation	The combination of the manifestations that encompasses <b>both specific symptoms/signs and non-specific findings</b>
Linear/ Multifactorial	<b>May be applied for a time span.</b> A disorder coding may be based on the main pathologic process which may show a causal relationship with the main manifestations in the patient	A pattern may be applied for a specific time span, too. However, a <b>pattern code is based on the summarised whole picture</b> that may be observed in the patient based on the perspectives of traditional medicine theories. A pattern is recognized based on the analysis of the systemic findings in the patient's body and mind which reflect the pathologic processes, responses to the pathologic processes, other concomitant findings, and innate or acquired constitutional traits of the patient
Commonality/ Individuality	Used to describe the <b>general characteristics considered to be relatively common</b> to the population suffering from one particular disorder	Used to describe the <b>individual characteristics considered to be relatively specific to the patient</b> at that time
General/ Theoretical	Usually described with <b>general terms of anatomy and physiology</b> together with terms of signs and symptoms	Usually described with <b>terms of the traditional medicine theories</b> that are used to summarise the underlying mechanism in the patient such as yin and yang balance, cold and heat, meridian, or constitution

### 3.2.27 Section V – Supplementary section for functioning assessment

This section is new. The list of 47 entities in this section is intended for assessment and scoring in the context of ICD. It is using ICF functioning domains of high explanatory power (ICF Annex 9). The categories are intended to be used as a set. The set has been defined in a way that general and domain specific summary scores can be calculated using the WHO

Disability Assessment Schedule 2.0 (WHO DAS 2.0) or the WHO Model Disability Survey (MDS).

### 3.2.28 Chapter X - Extension Codes

This chapter is new. Extension codes are envisaged as providing the basis for postcoordination of ICD–11 codes, being the repository for all codes in a linearisation that are not eligible for use as stem codes.

The different lists provide additional codes for clinical use as well as for injury research, device safety, drug safety, patient safety and cancer registration.

These codes are for optional use and will be used more likely in morbidity than in mortality.

### 3.3 Multiple Parenting

An entity may be correctly classified in two different places, e.g. by site or by aetiology. For a disease like oesophageal cancer this would mean that it could be classified to cancers (malignant neoplasms) or to conditions of the digestive system. In the same way, cerebral ischaemic conditions could be classified to the vascular system – where the problem arises – or to the nervous system – where the ischaemia impacts and manifests with symptoms.

Indications of multiple parenting:

- ‘Excludes’ or ‘Code elsewhere’ note
- Display of multiple parents in Foundation Component view
- Display of multiple parents in tabular list. Example for oesophageal cancer: primary parent malignant neoplasm will appear in black and the digestive system for the oesophageal cancer in grey

In the Foundation component, ‘excludes’ notes for these examples will mention possible parents (multiple parents). However, for the tabulation of statistical outputs from any tabular list, there can be only one parent for primary tabulation. When there are such multiple parents, in the Foundation Component view both parents will be displayed the same way. However, in a tabular list, the primary parent place will show the entity and its parents in black, and the secondary possible parent in grey.

Every time an entity is parented elsewhere, it will continue to show the code from the primary parent. The primary parent is sometimes referred to as the ‘Tabular list parent’.

### 3.4 The Content Model

The Content model is a structured framework that defines each entity found in the ICD in a standard way. The purpose of the Content model is to present the background knowledge that provides the basis for the description of each ICD entity in a systematic way to allow for computerisation. ICD–11 holds all of its content in the Foundation Component. Here, every entity is specified by a description, machine readable properties that have values, and one or more parent-child relationship(s). Additional links provide information for postcoordination. All of this multi-dimensional information is then combined to form a list with mutually exclusive categories - the tabular lists. The Foundation Component includes

information on where and how a certain entity is represented in a tabular list. An entity might become a grouping, a category, or just a term that is, for example, listed in the index.

Each ICD entity can be seen from different dimensions. The Content Model represents each one of these dimensions as a 'property'.

The key components of the descriptions of disease are included as different properties within the Content model. The main properties of the Content model are:

1. ICD Concept Title
2. Hierarchy, Type and Use
  - Parent
  - Type
  - Use
3. Textual Definition(s)
  - Description (short)
  - Definition (long)
4. Terms
  - Index terms
    - Synonyms Inclusion terms
  - Exclusion Terms
5. Clinical Descriptions
  - Body System(s)
  - Body Part(s) (Anatomical site(s))
  - Manifestation Properties
    - Signs and Symptoms
    - Findings
  - Causal Properties
  - Aetiology Type
    - Infection (agents)
    - Injury (mechanisms)
  - Risk Factors
  - Genomic Characteristics
  - Temporal Properties
  - Severity Properties
  - Functional Properties
  - Specific Condition Properties
  - Treatment Properties
  - Diagnostic Criteria

For each ICD entity, various properties can be given if necessary to reach the correct coding result. A coder can use the properties to better understand a condition and how to code it, and the properties allow a coder to determine where a condition is placed. Only properties that are absolutely necessary have been defined in order to avoid the necessity of frequent updates. Additions of property values at the international level are managed through the

regular update cycle whenever coding problems indicate the necessity to do so. The following is an example of the core properties:

### ICD entity: Invasive ductal carcinoma of breast

Properties	Value
Anatomy	Breast
Morphology	Invasive ductal carcinoma

The full range of different values for each given property is predefined using standard terminologies and ontologies. This range of values is called a 'Value set'.

Descriptions of ICD–11 entities inform analysts and translators about the meaning of an entity and its descriptive characteristics. There are two different types of descriptions: a short description (maximum of 100 words) that is available in both the content model and the tabular list, and a detailed description with comprehensive detail at the level required for each entity. The detailed description is labelled 'additional information' and appears only in online electronic versions. Coders are cautioned not to use the descriptions for coding. Coders must assign codes based on the diagnosis(es) documented by a clinician. However, the descriptor information that is included for the individual entities of the ICD-11 provides users of the ICD with clear insight regarding the intended meaning and scope of rubrics or terms in the tabular list and the Foundation Component. The descriptors guide translators, coders, and users of coded data. The goal is to enhance the comparability, consistency, and interpretation of coded information for everyone, everywhere. There are four levels of descriptor information in the ICD–11 content model:

- **Fully Specified Term** - This is an unambiguous title that does not assume context. For example, 'systemic illness with predominant gastrointestinal diarrhoeal symptoms attributable to vibrio cholera', as opposed to 'cholera' or 'other' (where the meaning of other would have been clear from the hierarchical context).
- **Short Description** - The short description is a characterisation (maximum of 100 words) of the entity that states things that are always true about a disease or condition and which are necessary to understand the scope of the rubric. Descriptions do not necessarily contain elements intended for use in common epidemiology or things that are clinical criteria.
- **Additional Information** - This is a text field that is not mandatory, but that may contain additional information about, or characteristics of the diseases or conditions included in the entity. This text field provides more context for the entity. For example, the most common epidemiologic circumstances, putative or highly suspected aetiologic agents, or other information that may not always be true but may be common, typical, or expected.
- **Clinical or Diagnostic Criteria** - It is intended to contain one or more scenarios of clinical criteria and characteristics that would be sufficient to diagnose the condition(s) or syndrome(s) of the given class or concept.

Such scenarios will contain multiple variations, or embedded logic to accommodate 'x out of n' variations, that are necessary or useful to make the diagnosis. For example, a myocardial infarction (MI) in high-resource diagnostic settings would typically include a longitudinal pattern of cardiac enzymes, specific electrocardiogram changes, and stereotypical

symptoms. However, only two out of these three needs to be present as there are such things as 'silent MIs' (without symptoms) and similar variations.

It is expected that these scenarios will be divided over technology capabilities. For example, diagnosing a myocardial infarction in the high-resource diagnostic settings would likely involve different technology and criteria than in low-resource settings. ICD diagnostic criteria draw on various WHO guidelines that have identified diagnostic rules. Extensions to the ICD, as specialty linearisations, may use such diagnostic rules.

The ICD-11 architecture, and the future evolution of this component of information, could eventually serve decision algorithms based on these criteria. Assignment of diagnoses and conditions could automatically be proposed from data arising in electronic medical records.

Diagnostic criteria describes diagnostic methodology that determines how health providers diagnose cases that are classified to an entity. It contains the core diagnostic information necessary and sufficient to describe a category, and enables the digital representation of the diagnostic algorithms using standardised terminology and other elements as appropriate. There may be different sets of diagnostic criteria for different settings. Diagnostic criteria will draw on the content of other attributes.

### 3.5 Language independent ICD entities

ICD-11 entities are language independent. All entities have a unique identifier or uniform resource identifier (URI) and have a specific place in a hierarchy of groups, categories and narrower terms. The maintenance of the ICD-11 on an international level is handled in the English language but the content model of the ICD-11 is language independent and allows binding of any desired language to the elements of its foundation. In this way, an international translation base facilitates translations and multilingual browsing. The URI remains valid independent of whether an ICD entity is still valid or has been retired. The hierarchical structure of groups, categories, subcategories, and inclusions (parents, children and narrower terms) serves also as a language independent backbone for translations of ICD. This structure is essential when building an index in a local language. It helps (in conjunction with the ICD translation platform) to identify the things that need to be translated in order to be able to address ICD categories with terms reported in the local language.

### 3.6 Innovation to mortality coding in ICD-11

Mortality coding instructions of ICD have matured over time and basically has been maintained for ICD-11, while the text has been formatted using easier wordings to enhance common understandings and standardised implementation. Major changes in the classification have been incorporated in the mortality coding instructions.

New concepts or terminology of ICD-11, for instance postcoordination or cluster coding, 'code also' and 'use additional code if desired' instructions will function to capture further information reported on the death certificate. In ICD-10 mortality coding, multiple cause coding, several modification rules in Step M4, or certain flags used in automated coding systems has been used to capture details reported on the death certificate and to facilitate accurate selection of underlying cause. And in this sense, it is considered that the function of postcoordination etc. has been embedded in ICD-10 mortality coding practice, while in



ICD-11 the concepts are more evident and several new instruction were added to inform on how to apply these new concepts (see Part 2 of this Reference Guide).

The following table used in Step M1 for coding complications of diabetes mellitus is provided for optional use. This list is not a complete list of possible complications of diabetes mellitus, and is intended not to be updated but kept for users who are interested in consistency between ICD-10 and ICD-11 coding.

<b>TUC diabetic complication in ICD-11</b>	If desired, postcoordination may be used to specify complication of diabetes mellitus with mention of:
(ketoacidosis)	<a href="#">5C73</a> Acidosis <a href="#">5C50.G</a> Trimethylaminuria <a href="#">MA18.Y</a> Other specified abnormal findings of blood chemistry
(renal complications)	<a href="#">GB40-GB4Z</a> Glomerular diseases <a href="#">GB61</a> Chronic kidney disease <a href="#">GB6Z</a> Kidney failure, unspecified <a href="#">MF54.0</a> Smooth contracted kidney <a href="#">GB90.4Z</a> Renal tubular function disorders, unspecified
(ophthalmic complications)	<a href="#">9A96.Z</a> Anterior uveitis, unspecified <a href="#">9B10.Z</a> Cataract, unspecified <a href="#">9B65.Z</a> Posterior uveitis, unspecified <a href="#">9B78.1</a> Background retinopathy and retinal vascular changes <a href="#">9B78.2</a> Other proliferative retinopathy <a href="#">9B7Z</a> Disorders of the retina, unspecified
(neurological complications)	<a href="#">8C12</a> Certain specified mononeuropathies  <a href="#">8C1Z</a> Mononeuropathy of unspecified site <a href="#">8C0Z</a> Polyneuropathy, unspecified <a href="#">8C4Y</a> Other specified disorders of nerve root, plexus or peripheral nerves <a href="#">8C7Y</a> Other specified primary disorders of muscles <a href="#">8D8Z</a> Disorders of autonomic nervous system, unspecified
(peripheral circulatory complications)	<a href="#">BD40.0</a> Lower limb atherosclerosis  <a href="#">BD4Z</a> Chronic arterial occlusive disease, unspecified <a href="#">EE80.1</a> Necrobiosis lipoidica <a href="#">MC85</a> Gangrene
(other specified complications)	<a href="#">ME60.2</a> Ulcer of skin of uncertain nature, specified as lower limb <a href="#">FA2Z</a> Inflammatory arthropathies, unspecified <a href="#">MG30.5Z</a> Chronic neuropathic pain, unspecified
(coma)	when reported as the cause of: <a href="#">MB20.1</a> Coma
(ophthalmic complications)	<a href="#">9C81.Z</a> Palsy of unspecified ocular motor nerve

**TUC diabetic complication  
in ICD-11**

If desired, postcoordination may be used to specify  
complication of diabetes mellitus

(neurological  
complications)

[9D90](#) *Vision impairment including blindness*

[8E7Y](#) *Other specified diseases of the nervous system*

(peripheral circulatory  
complications)

[DA7Z](#) *Diseases of the stomach or the duodenum,  
unspecified*

(other specified  
complications)

[1A40](#) *Gastroenteritis or colitis without specification of  
infectious agent*

[1G40-1G41](#) *Sepsis*

[1C41](#) *Bacterial infection of unspecified site*

[1F28](#) *Dermatophytosis*

[1F2D](#) *Non-dermatophyte superficial dermatomycoses*

[1F23](#) *Candidosis*

[3B20](#) *Disseminated intravascular coagulation*

[5A41](#) *Hypoglycaemia without associated diabetes*

[5C80.00](#) *Primary hypercholesterolaemia*

[5C80.1](#) *Hypertriglyceridaemia*

[5C80.2](#) *Mixed hyperlipidaemia*

[5C80.Z](#) *Hyperlipoproteinaemia, unspecified*

[5C76](#) *Hyperkalaemia*

[5D2Z](#) *Metabolic disorders, unspecified*

[8A42.Y](#) *Other specified acute disseminated  
encephalomyelitis*

[8A42.Z](#) *Acute disseminated encephalomyelitis, unspecified*

[BA00.Z](#) *Essential hypertension, unspecified*

[BA01](#) *Hypertensive heart disease*

[BA40-BA6Z](#) *Ischaemic heart diseases*

[BB40-BB4Z](#) *Acute or subacute endocarditis*

[BC0Z](#) *Heart valve diseases, unspecified*

[BC43.0Z](#) *Dilated cardiomyopathy, unspecified*

[BC43.Z](#) *Cardiomyopathy, unspecified*

[BC81.3](#) *Atrial fibrillation*

[BC81.20](#) *Cavotricuspid isthmus dependent macroreentry  
tachycardia*

[BC81.2Z](#) *Macro reentrant atrial tachycardia, unspecified*

[BC60](#) *Atrial premature depolarization*

**TUC diabetic complication  
in ICD-11**

If desired, postcoordination may be used to specify complication of diabetes mellitus

[BC61](#) *Junctional premature depolarization*

[BC70](#) *Ventricular premature depolarization*

[BC71.1](#) *Ventricular fibrillation*

[BC80.20](#) *Sick sinus syndrome*

[BC9Y](#) *Other specified cardiac arrhythmia*

[BC9Z](#) *Cardiac arrhythmia, unspecified*

[BD10-BD1Z](#) *Heart failure*

[BE2Z](#) *Diseases of the circulatory system, unspecified*

[8B00](#) *Intracerebral haemorrhage*

[8B02](#) *Nontraumatic subdural haemorrhage*

[8B03](#) *Nontraumatic epidural haemorrhage*

[8B0Z](#) *Intracranial haemorrhage, unspecified*

[8B11](#) *Cerebral ischaemic stroke*

[8B20](#) *Stroke not known if ischaemic or haemorrhagic*

[8B22.Y](#) *Other specified cerebrovascular disease*

[8B2Z](#) *Cerebrovascular diseases, unspecified*

[8B25.1](#) *Late effects of intracerebral haemorrhage*

[8B25.3](#) *Late effects of other nontraumatic intracranial haemorrhage*

[8B25.0](#) *Late effects of cerebral ischemic stroke*

[8B25.4](#) *Late effects of stroke not known if ischaemic or haemorrhagic*

[8B25](#) *Late effects of cerebrovascular disease*

[8D40.1](#) *Neuropathy due to nutritional deficiency*

[8D40.2](#) *Myopathy due to nutritional deficiency*

[8D40.Y](#) *Other specified neurological disorders due to nutrient deficiency*

[8D40.Z](#) *Neurological disorders due to nutrient deficiency, unspecified*

[BD30.20](#) *Acute thromboembolic lower limb arterial occlusion*

[BD30.0](#) *Acute upper limb arterial occlusion*

[BD30.2](#) *Acute lower limb arterial occlusion*

[BD70](#) *Superficial thrombophlebitis*

[BD72](#) *Venous thromboembolism*

[CA40.1](#) *Viral pneumonia*

[CA40](#) *Pneumonia*

## TUC diabetic complication in ICD-11

If desired, postcoordination may be used to specify complication of diabetes mellitus

[DA60-DA63.Z](#) *Ulcer of stomach or duodenum*

[ME24.Y](#) *Other specified clinical manifestations of the digestive system*

[1B70.3](#) *Ascending bacterial lymphangitis*

[1B70.Y](#) *Bacterial cellulitis or lymphangitis due to other specified bacterium*

[1B70.Z](#) *Bacterial cellulitis or lymphangitis due to unspecified bacterium*

[EB21](#) *Pyoderma gangrenosum*

[EA3Z](#) *Unspecified skin disorder attributable to viral infection*

[EA89](#) *Generalised eczematous dermatitis of unspecified type*

[EH90](#) *Pressure ulceration*

[FA26.2](#) *Chondrocalcinosis*

[1B71](#) *Necrotising fasciitis*

[GC08.Z](#) *Urinary tract infection, site and agent not specified*

### 3.7 Innovation to morbidity coding in ICD-11

#### ‘Present on Admission’

The inclusion of the new Extension codes in ICD-11 provides capacity for coding qualifying information of linked stem codes. Among the new qualifying features is the particularly important status display feature that allows for distinction of diagnoses present at admission from diagnoses arising after hospital stay began.

### 3.8 Functioning section

An optional functioning section has been embedded in ICD-11 to enable the classification and measurement of the impact of health conditions in terms of functioning. For further information see section [1.1.6.2](#).

Overall, the linkage between ICD-11 and ICF may assist with the following use cases:

- evaluation for general medical practice (e.g. work in capacity assessment)
- evaluation for social benefits (e.g. disability pension)
- payment or reimbursement purposes
- needs assessments (e.g. for rehabilitation, occupational assistance, long term care)
- outcome evaluation of interventions

Wherever full *functioning* reporting is desired and required, the ICF should be used.

### 3.9 General features of ICD-11

The main structural innovation of ICD-11 is that it is built on a Foundation Component from which the tabular list can be derived. The international reference tabular list is the statistical classification for morbidity and mortality. Due to the addition of a Foundation Component, and the electronic design of ICD-11, a new terminology had to be introduced that had not been used in prior versions of ICD. (See Section [2.13](#) for further information.)

For more detail on the terminology of ICD-11, see Section [1.1.6.1 Integrated use with Terminologies](#).

### 3.10 Traditional Medicine conditions - Module 1 (TM1)

A large percentage of the world's population uses some form of Traditional Medicine. However, standardised data and information on health status of these users remain largely absent from national and international health data collections. The use of Complementary and Alternative Medicine (CAM) therapies has become a huge industry and is expected to grow. As a result of this gap in information about TM and the size of the industry, resources have been invested in the creation of a classification tool to allow data to be collected and analysed.

ICD-11's supplementary chapter on Traditional Medicine disorders and patterns is designed to be integrated with coding of cases in conjunction with the Western Medicine concepts of ICD Chapters 1-25.

As with other ICD chapters, the TM1 chapter is a tool for classifying, diagnosing, counting, communicating and comparing TM conditions, it will also assist research and evaluation to assess the safety and efficacy of TM. This chapter not judging TM practice or the efficacy of any TM intervention.

This chapter must not be used in mortality coding.

### 3.11 Preparations for the Eleventh Revision

By 2003, it was becoming clear to the WHO and the Collaborating Centres that a further revision of the ICD could not be long delayed. The extent to which ICD updating could encapsulate emerging developments was limited by the structure of ICD-10, and some issues needed extended development and discussion with expert groups. A special meeting of Collaborating Centres in Helsinki in 2004 discussed the need for a revision and issues to be addressed as part of the revision process. The 2004 WHO-FIC meeting subsequently adopted a revision process work-plan which was progressively developed at ensuing meetings.

In 2007, the WHO formally launched the revision process. Oversight has been provided through a broad-based Revision Steering Group. Technical work has been undertaken by a series of Technical Advisory Groups, with cross-cutting groups examining mortality, morbidity and quality and safety issues. For the first time, a chapter on description of diseases and patterns of diseases from a Traditional medicine standpoint has been included.

A Content Model, including a range of components for each ICD entity has been developed, giving a rich foundation for the ICD. Other classifications and terminologies are linked or

included where possible to ensure ICD is aligned with them, and items used in other members of the WHO Family of Classifications have been aligned wherever possible. The more traditional statistical classification for mortality and morbidity is obtained from the Foundation Component of ICD–11 as a Tabular list. Extension codes are used to limit content volume but still allow detailed classification of disease entities. Supplementary chapters and sections allow capturing on an optional basis information about traditional medicine diagnoses and functioning. Based on the experiences with ICD-9 and ICD-10 an updating mechanism was designed, that allows improvements in user guidance and scientific updates without compromising the statistical use of the classification.

The revision of ICD-11 has taken place in several phases. First, a list of issues that were known from the use of ICD-10 and that could not be solved in its classification structure was compiled and possible solutions were formulated.

Second, input was received from many scientific groups in the key subject areas, with a focus on clinical perspectives.

Finally, centralised editing occurred, aimed to adjust imbalances in content generated by multiple, independently operating expert groups in the previous phase of the revision, and to ensure the overall structure is consistent and practicable for users for mortality and morbidity statistics. The final version also received input from field testing, Member State comments, and ongoing submission and processing of proposals.

### 3.12 Annex A: ICD-11 Updating and Maintenance

This Annex describes the review process, the release cycles and the proposals workflow for updating ICD-11.

Official releases of the ICD-11 classification are produced annually for international use in mortality and morbidity (this is known as the ‘blue browser’). By contrast, the ICD-11 Foundation Component is continuously updated. The updating is carried out at different levels with corresponding different frequencies.

The ICD-11 is being released in five-yearly ‘stable’ versions for international use (contains updates that impact on the four- and five- character structure), unless urgent public health needs require otherwise. The releases are supplemented with version identifiers that are used for reporting in conjunction with the codes. Transition tables and materials showing the differences are provided with every version.

Updates at a more detailed level than four- and five- characters can be published annually. Small error corrections that serve to clarify meaning, indexing or errors, may be communicated annually. Additions to the index can be done on an ongoing basis.

Mortality and morbidity rules will be updated in longer term cycles of every 10 years.

All countries that have implemented the ICD-11 are encouraged to adopt the updates in order to ensure greatest possible standardisation of coding results. If a country for whatever reason cannot implement a certain year of updates it shall at least ensure that the reported data is in line with the most recent version of ICD-11.

The WHO has taken all reasonable precautions to verify the information contained in the ICD and its different versions and editions. However, the ICD is being distributed without warranty of any kind, either expressed or implied. The responsibility for the interpretation and use of ICD lies with the user. In no event shall the WHO be liable for damages arising

from its use.

The publisher of ICD-coded information is liable to ensure proper use of the ICD and present clearly the methodology for data collection and mechanisms that were used to modify the original data in order to indicate the comparability of the presented outcomes. For mortality data, no deviation from the methodology indicated in the ICD is permitted.

For information on taxonomy and structuring see [1.2](#).

### 3.12.1 Background

Updating ICD-11 makes sure that ICD meets the needs of users in content and terminology.

Updating and decisions follow the principles laid out in [1.2.1 Taxonomy](#).

Updates include changes to chapters 01-24 of ICD, the supplementary chapter for traditional medicine conditions (including the development of additional modules), the supplementary section for functioning assessment, the extension codes, special views and special tabulation lists, elements of the foundation of ICD, as well as changes to the reference guide.

All proposals are entered on an online maintenance platform, for verification of completeness, discussion and editing. The platform provides the infrastructure for routing proposals to reviewers and experts, and for providing feedback to the original authors. The maintenance platform also shows the final outcome of the proposal that has been entered in the authoring platform and become part of the ICD. Any individual user of the classification can submit a proposal for an update to the ICD. Such updates can refer to one or more entities of the ICD. They may address the position of entities in a tabular list, in the Foundation Component, and any element of the content model. The maintenance platform of ICD-11 (known as the 'orange browser') is used for proposals and comments. Any input to ICD-11 and its components requires proper referencing of sources, details of scientific evidence, and permission from the owner of any copyright materials (where applicable).

The proposals will be reviewed by scientific experts and classification experts. The decision regarding the outcome of a particular proposal will be based on the recommendations by these experts.

A workflow between a mortality reference group (MRG) and a morbidity reference group (MbRG), a medical scientific advisory committee (MSAC), and the overall overseeing classification and statistics advisory committee (CSAC) will ensure that all aspects concerning a proposal are considered. Reviews of the synthesis by classification experts ensure suitability of the proposed changes to the diverse use cases of the ICD.

The process is based on consensus of the members of the CSAC about a proposed change. All rounds of editing will be handled through electronic platforms. Where consensus cannot be achieved, the proposal can either be deferred to subsequent cycles of editing pending arbitration by the WHO or be solved in a face-to-face meeting of classification and content experts. In all other cases, a consensus recommendation is given to WHO for final decision.

All proposals for change must be submitted through the proposal mechanism to ensure a clear and transparent review of the proposed content. The different types of proposals that may move through a workflow in order to ensure consistency, structural integrity, and



scientific correctness of the classification. The different workflows warrant proper use of the available resources of the WHO Family of International Classifications WHO-FIC Network and WHO. All changes are reported. Several steps may be needed for verification of updates.

### 3.12.2 Updating Cycle

The updating is carried out at different levels with different frequencies. That will keep stability for mortality and allow quicker updates for morbidity use.

- Updates that impact on international reporting (the four and five-character structure of the stem codes) will be published every five years.
- Updates at a more detailed level can be published at annual rates and pending the needs of clinical modifications also twice a year.
- Additions to the index can be done on an ongoing basis.
- Mortality and morbidity rules will be updated in a 10-year cycle.
- Other updates to the reference guide can be published at annual rates.

#### 3.12.2.1 Types of proposals for ICD-11-MMS maintenance

After reviewing the established proposal types and criteria of ICD-10 and those used thus far during ICD-11 Revision, taking into context the needs of ICD-11, the following proposal types for ICD-11 are proposed (see Table below for impact on Morbidity and Mortality Statistics (MMS)).

- **Add new entity:**
  - to add an entity 'below the shoreline' (becoming an index entry in MMS)
  - to add an entity 'above the shoreline' (becoming a category in MMS)
- **Delete entity:**
  - applicable to an entity below the shoreline (removing an index term from the MMS)
  - applicable to an entity above the shoreline (removing a category from the MMS)
- **Change of Coding Status:**
  - moving an entity from the index into the MMS (e.g. giving it an individual code), or an entity from the MMS to the index (e.g. eliminating the individual code and directing it elsewhere)
- **Content Enhancement** including the following subtypes:
  - Change of Preferred Term (title) (Changes to a code that affect the meaning of that code are not allowed and will not be accepted. If a concept is

outdated and must be updated, or a new concept is necessary, the relevant delete entity or add new entity proposal types, or both, must be used.)

- Addition / Deletion of a synonym
- Addition / Deletion of an exclusion
- Change of Description (Definition)
- Change of Additional Information (Long Definition)
- Correction of spelling or grammar (in any field)
- Addition / Deletion of a mandatory postcoordination combination of stem codes
- Addition / Deletion of entity rubric content (does not allow change to meaning)
- **Structural Change** including the following subtypes:
  - Change a primary parent link
  - Change a secondary parent link
- **Reference Guide Change** applicable to any text of the ICD-11 Reference Guide, including coding rules and defaults, etc. Subtypes include:
  - Correction of spelling or grammar
  - Clarification of a rule
  - Change to a rule (that effects data integrity), including changing a coding hint
- Proposals for clarification that do not require change to the classification
- Correction of inconsistency between volumes

Ideally, each proposal will specify if it relates to the foundation or to a classification, including if it is for a national clinical modification or specialty linearisation. Tick boxes in the proposals will allow to indicate the scope.

Not all authors will be familiar with these distinctions. The default may assume that the proposal relates to the ICD-11 MMS, unless specified otherwise. Regardless, the CSAC will need to determine if the item, once accepted, will be ‘above or below the shoreline’ in the ICD-11 MMS.

Not all proposals will require the same level of scrutiny, as each may be considered in the context of its impact on the statistical classification and the desirability for a scientifically accurate and up-to-date classification. A ‘fast track’ to review urgently needed updates, such as for national clinical modifications will be put in place as needed. Criteria and a specific workflow exist for each ‘track’ used for proposals.

**Table 1:** Overview of ICD-11 maintenance proposal types and their potential impact on MMS-collected data. List does *not* imply a hierarchy of prioritization. ‘X’ means applies.

<b>Proposal Type</b>	<b>Major</b>	<b>Minor</b>	<b>None</b>
<b>Add new entity</b>	X	X	
<b>Delete entity (+)</b>	X		
<b>Change of Coding Status</b>	X	X	
<b>Content Enhancement</b>			
Change of Preferred Term (title)	X	X	X
Addition/Deletion of a synonym		X	
Addition/Deletion of an exclusion		X	
Change of Description	X	X	X
Change of Additional Information (Long Description - outside WHO)			X
Correction of a typo (in any field)			X
Addition/Deletion of mandatory postcoordination combination of stem codes	X		
Addition/Deletion of entity rubric content – no change to meaning			X
<b>Structural Change</b>			
Change a primary parent	X		
Change a secondary parent			X
<b>Reference Guide change</b>			
Correction of a typo			X
Clarification of a rule			X
Change to a rule (that affects data integrity), including changing a coding hint	X		

(+) Errors are deleted; obsolete terms and entities are not deleted as they assist with mapping and coding as they may still be in use

**Table 2:** Groups responsible for maintenance of potential changes.

<b>Proposal Type</b>	<b>CSAC</b>	<b>MSAC</b>	<b>MRG</b>	<b>MbRG</b>	<b>FDGRG or TM</b>
<b>Add new entity</b>	X	X	X	X	X+
<b>Delete entity (+)</b>	X	X	X	X	X+
<b>Change of Coding Status</b>	X	X	X	X	
<b>Content Enhancement</b>					
Change of Preferred Term (title)	X	(X)			X+
Addition/Deletion of a synonym**					X+
Addition/Deletion of an exclusion**					
Change of Description	X	X	X	X	X+
Change of Additional Information (Long Description - outside WHO)		(X)			X+
Correction of a typo (in any field)**					
Addition/Deletion of mandatory postcoordination combination of stem codes	X		X	X	
<b>Structural Change</b>					
Change a primary parent	X	(X)	X	X	X+
Change a secondary parent	X	X			
<b>Reference Guide change</b>					
Correction of a typo**					
Clarification of a rule	X		X	X	X+
Change to a rule (that affects data integrity), including changing a coding hint	X	(X)	X+	X+	X+

(+) errors are deleted; obsolete terms and entities are not deleted as they assist with mapping and coding as they may still be in use. (X) applies only in special situations. X+ applies only for the specific use case. \*\* WHO team

### 3.12.3 Proposal completeness

Any individual can submit a proposal for an update to the ICD. Proposals shall be provided in the format of a short (approximately 500-words) explanation with references to underpinning literature and evidence (publications in peer reviewed journals, or in official meetings of WHO, its CC or NGO in official relationships). The proposal shall also visualize the changes in the position and address potential impact on entities outside the proposal.

- The author has to register with full name and affiliation and declare any possible conflict of interest.
- All proposals must have a clearly written and compelling rationale, with citations to establish the proposals' evidence base.
- Proposals that suggest adding entities must have a description, and a description of the entity. This ensures the correct placement in the foundation. The rationale must

have a scientific background, with references to publications in peer reviewed journals, or in official meetings of WHO, its CC or NGO in official relationships.

- Proposals for new codes should include information about how the case would be coded if the proposed new code is not accepted.
- Proposals with impact on the statistics must include a description or analysis of the resulting impact like frequency.
- Proposals suggesting rule changes must come with an impact analysis.
- An incomplete proposal will be returned to the author.
- The proposal mechanism will not allow submitting proposals without rationale or with missing description or definition, adequate to process the proposal.

### 3.12.4 Proposal Timelines

Proposals can be submitted at any time. No impact proposals are processed on an ongoing basis, proposals requiring review by any of the groups and committees involved in the workflow, are bundled every 28 February of a year and routed in the necessary workflow.

Proposals are processed in parallel by the relevant groups. Formal comments are provided in two rounds (two months, one month) -offering the opportunity for edits in between. Final decision about acceptance, rejection or ‘further discussion’ is taken at a teleconference of the CSAC at the WHO-FIC annual meeting in October every year. Official releases are published end of September for validity according to the updating cycle of the kind of proposal, earliest being proposals for adoption in January of the following year (minimum six months for translation, three months for formal dissemination, e.g. for clinical detail, secondary parents or synonyms).

## Review and Release Schedule

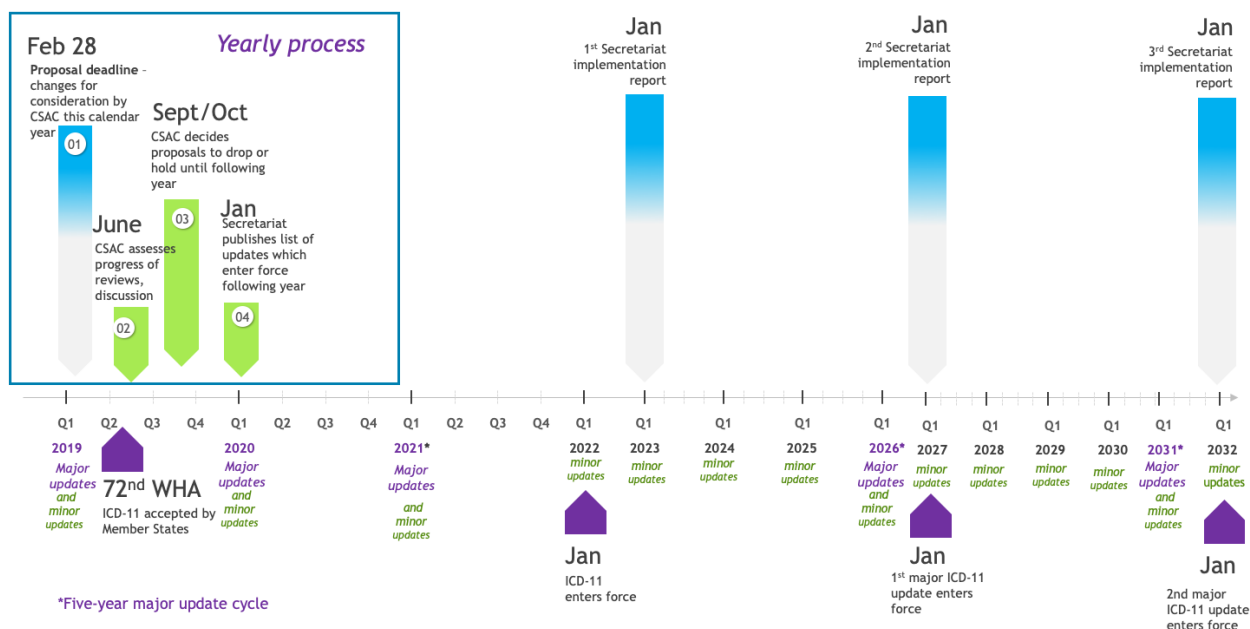

### Proposal and Release Timelines

### 3.12.5 Proposal Workflow

ICD maintenance is a process that requires broad expertise in statistics and medical science as well as in different use cases. It has already been established that the structure associated with ICD update and maintenance will be revised in line with new requirements and efficient use of limited resources. The figure below shows the flow by which proposals received through the update platform might move through the expert groups for review and recommendation to WHO. A 'proposal triage' will initially review all proposals received to ensure that they are complete and have been submitted correctly. The proposals will then be forwarded to the appropriate next step(s). This triage may identify proposals that can or must be processed in an accelerated process, such as due to the type of proposal or in cases of extreme urgency. The proposed typology of proposals may help to identify the impact on the classification which will, in turn, inform whether the proposal is an improvement or clarification that can be implemented on an ongoing basis, or if the change must be queued for implementation on the updating cycle. The threshold for considering proposals to the foundation is low, allowing for simple rules to identify what is 'receivable/actionable' namely, if it is complete and correct, it may be considered. Consideration does not guarantee acceptance.

The CSAC is composed of:

- WHO-FIC Collaborating centres and officially nominated technical representatives from WHO member states. The participants and observers have specific knowledge and expertise in the classifications
- Two cochair from each Reference Group (Mortality Reference Group (MRG), Morbidity Reference Group (MbrG) and Functioning and Disability Reference Group (FDRG), Traditional Medicine Group (TMRG)) as well as two cochair from the Medical and Scientific Advisory Committee (MSAC) are also included ex officio, with the right to comment but no right to vote.
- Additional experts may be invited to participate in CSAC meetings for commenting on specific items.

All decisions are based on consensus. Terms of reference of the working groups are included in the document that describes the [conduct of the WHO Family of International Classifications Network](#).

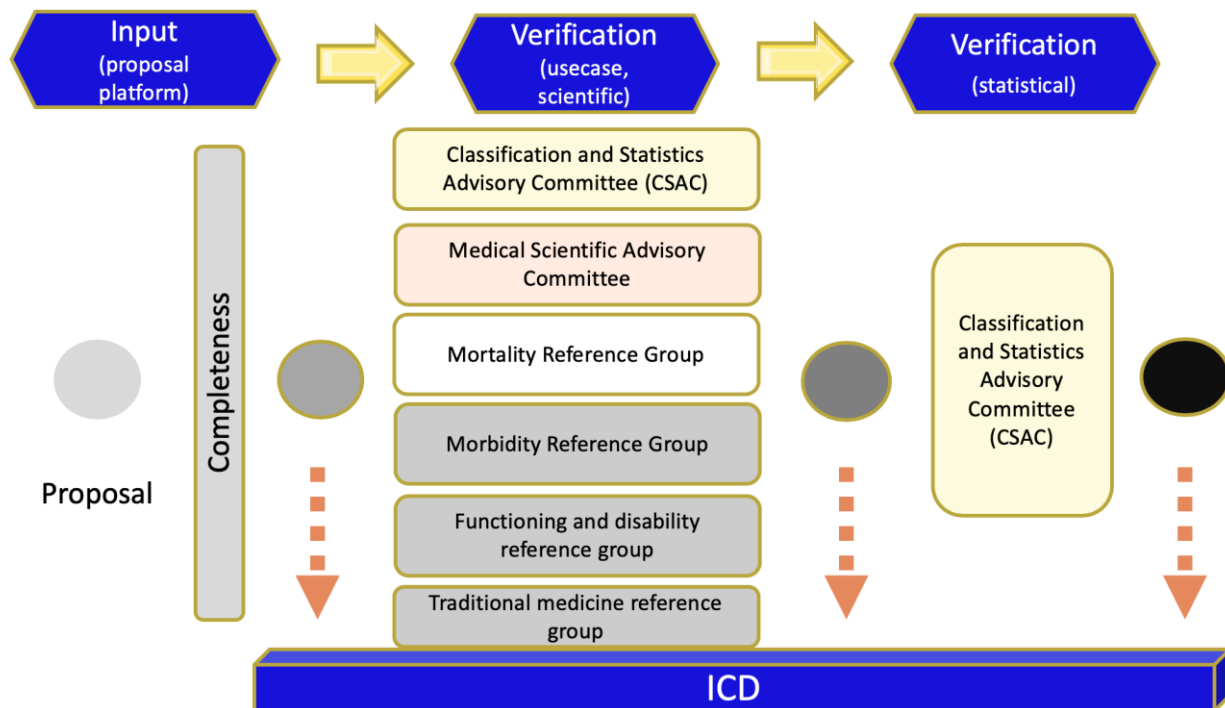

### *Proposal Workflow*

Proposal Workflow see [Conduct of the WHOFIC Network](#) for ToR and Governance of the different groups.

### *CSAC Small Group*

This group consists of the CSAC co-chairs and secretariats, WHO staff and experts selected by WHO.

The CSAC Small Group reviews each proposal and determines if the proposal is ready for review by the full CSAC. The Small Group also makes a recommendation by consensus as to whether the proposal should be accepted or rejected. If a proposal requires more information or is incomplete, the CSAC Small Group may request further advice from MSAC or other committees and reference groups (C&RG) or send the proposal back to the author. Sometimes, the Small Group, MSAC and/or a C&RG make a recommendation for a modification to the original proposal, and this is recorded in the public comments section of the proposal by the secretariat of the group. These comments and proposed modifications are then considered by the full CSAC.

When a proposal is ready for review by the wider CSAC, the CSAC Secretariat records the recommendation of the CSAC Small Group, and any suggested modifications and the reasons for these, on the public comments section of the proposal and allocates the proposal to have the status 'CSAC Voting'. CSAC members can then indicate their agreement and/or comment on the proposal, as modified by the CSAC Small Group, as applicable.

### 3.12.6 Changes that cannot be done during the normal updating process

Changes that create new structures that conflict with the existing structure or coding of a current revision can be carried out only within a new revision of ICD and they include:

1. Changing an existing code of a category
2. Changing an existing grouping into a category if it has children in the linearisation (Allowing this would force changing the codes of the children therefore it is not allowed)
3. Changing an existing category into a grouping if it has children in the linearisation (Same as above)
4. Inserting a category in between two existing sibling categories. Categories to an existing siblinghood needs to be entered at the end before the residuals.
5. Re-ordering of any kind will not be possible as the ordering would be based on the codes which will not change.
6. Retiring an entity that contains children that are not retired and replacing it with another entity that contains the old children. (This is not possible because the new entity cannot keep the same code of the retired one and if we give a new code its code will not be compatible with the children.)
7. Moving an existing category in a way that would imply changing its code. E.g. the category 2B01.2 cannot be moved which is under [2B01](#) as a child of 2B00

For Chapter X 'Extension codes' the only limitation is number 1 above. Any other change could be done as the codes of Chapter X are not based on their hierarchical location.

### 3.12.7 Applicability and Intellectual Property

The following paragraph provides an extract of some of the legal regulations in relation to ICD. It is noted that this text does not prejudice in any way the wording of any legal arrangements that are made between WHO and other relevant parties. The binding official version of the ICD license is available at <https://icd.who.int/en>.

The ICD is the intellectual property of WHO and changes to the ICD are subject to contractual arrangements and approval through the updating mechanism.

ICD-11 is licensed under the Creative Commons Attribution-NoDerivs 3.0 IGO license (CC BY-ND 3.0 IGO, or the "ICD-11 License", available at <https://creativecommons.org/licenses/by-nd/3.0/igo/>). Under the terms of the License, you are NOT permitted to make "adaptations" of ICD-11, as defined in the License. In that regard, and without otherwise limiting the terms of the ICD-11 License, WHO provides the following clarifications:

- To prevent the dilution of ICD's purpose to provide a definitive standard for identifying health information, neither the Licensed Materials, nor any portion thereof, may be used for the purpose of developing or promulgating a different standard.
- WHO does not consider incorporation of ICD-11 into a software product to be an "adaptation", provided that you do not do any of the following:



- 
- a. Reproduce ICD-11 in part or whole and distribute it under a different name or without attribution;
- 
- b. Reproduce and distribute ICD-11 in part or whole without the ICD-11 codes;
- 
- c. Reproduce ICD-11 in part or a whole without the ICD-11 URIs; or
- 
- d. Reproduce and distribute ICD-11, in part or whole, with any combination of a-c above.
- Mappings or crosswalks between other classifications and terminologies and ICD-11 are not covered by the ICD-11 License and are subject to a separate written agreement from WHO
- Adding data fields to ICD-11 concepts is permitted if such additions are clearly identified as additions that do not originate from WHO.
- Web services for ICD coding and browsing and other software are available under a non-exclusive, non-transferable and non-assignable royalty-free license to use and incorporate the ICD-11 Software in computer applications or systems (the “Software License”). Such computer applications or systems incorporating the ICD-11 Software, may be licensed to users for commercial and non-commercial purposes. Users are not granted the right to sell or license the ICD-11 Software as a standalone product. For the avoidance of any doubt the ICD-11 Software is not licensed under the Creative Commons license for the ICD-11 described in Section 1, above.

The ICD may be translated into any language. For translation, interested parties (the Translator) are requested to contact the WHO and comply with the relevant regulations and receive written permission in a formal contract. Usually translation rights are granted only to ministries of health.

The translations into the UN languages are a product of the WHO and all rights are vested with WHO. Translations into other languages are a product of the Translator.

The Translator will use the WHO translation platform, thus allowing the WHO to verify correctness and completeness of the translation.

WHO is automatically granted a perpetual and irrevocable, non-exclusive, world-wide, royalty-free, sub-licensable right to use, change, adapt, translate, publish, and disseminate such work product in any manner and in any format in conjunction with the work of WHO.

In some instances, users determine the need to change parts of the ICD in order to produce a special version of ICD. Production of special versions requires a dedicated contractual arrangement with WHO.

Such versions will be produced from the WHO production platform by WHO.

All changes or suggestions for changes to the ICD must be submitted to the WHO-ICD maintenance platform (for details see [3.12 Annex A: ICD-11 Updating and Maintenance](#)).

Requests for production of a special version will be subject to the provision of resources necessary for the WHO to generate the specialty version.

No publicity or advertising may be displayed in the coding or browsing pages. In case of embedding of the classification in a local website, or running a local version, a link to the ICD homepage at the WHO must be included.

No publicity or advertising may be displayed in the ICD print versions.

Ideally users will access the ICD online or through the web services provided by the WHO. This will ensure proper joint use of the index, content model, and tabular lists and facilitate dissemination of updates, where applicable. Any coding mechanism produced by 3rd parties must provide the same coding results as the reference online coding tool.

For national and international recording and reporting, the most up to date version of the ICD is to be used, as stipulated in the Nomenclature Regulations (1967).

### **Modifications for morbidity coding**

The use of ICD in the specific context of the health care system of a country may require detail that is not currently part of ICD-11, for example, due to specific settings or due to reimbursement system requirements. Such changes will be subject to the same international process as are all other changes to ICD and will then become part of the Foundation Component and eventually of the Mortality and Morbidity Statistics (MMS), ideally prior to their implementation in the requesting country.

A situation may arise, where a national government or a related national institution needs a modification to be implemented immediately. In such circumstances, conflicts with the current Foundation Component must be avoided, and the relevant changes will be subject to special mechanisms for the international updating process. All countries planning to produce modifications must make relevant contractual arrangements with WHO. This includes regulations on distribution within and outside the respective country and the resources necessary for the WHO to add such changes to the Foundation.

For developing a national modification of ICD-11 the following rules must be adhered to: 1. Modifications will be agreed by the ICD-11 maintenance bodies before they are implemented nationally. 2. Modifications must not impact on morbidity and mortality statistics, and must not conflict with the Foundation. 3. Approval of all modifications will be subject to consideration of whether suitable additional detail already exists in the Foundation. 4. If a change is made to the international version of ICD-11 the respective modification must incorporate the change as soon as possible.

### **Example**

'Diabetes Type 1' in the WHO version of ICD-11 is classified to [5A10](#). A national modification may require additional detail to be added to the ICD-11 codes. For example, 'Diabetes Type 1, uncontrolled' could be added as a subcategory to [5A10](#), as 5A10.1 Diabetes Type 1, uncontrolled. However, when the mechanism of postcoordination provides the necessary detail, the addition of a new subcategory may not be necessary.

## 3.13 Annex B: History of the development of the ICD

### 3.13.1 Early history

Sir George Knibbs, the eminent Australian statistician, credited François Bossier de Lacroix (1706-1777), better known as Sauvages, with the first attempt to classify diseases systematically (1). Sauvages' comprehensive treatise was published under the title *Nosologia methodica*. A contemporary of Sauvages was the great methodologist Linnaeus (1707-1778), author of *Genera morborum*, a catalogue of diseases. More recently, Moriyama et al (2) have referred to 16th century and 17th predecessors Fernel and Sydenham. At the beginning of the 19th century, the classification of disease in most general use was one by William Cullen (1710- 1790, of Edinburgh, which was published in 1785 under the title *Synopsis nosologiae methodicae*.

For all practical purposes, however, the statistical study of disease began a century earlier with the work of John Graunt on the London Bills of Mortality published in 1662. The kind of classification envisaged by this pioneer is exemplified by his attempt to estimate the proportion of liveborn children who died before reaching the age of six, when no records of age at death were available. He took all deaths and classed them using terms from the time, such as thrush, convulsions, rickets, teeth and worms, abortives, chrysmes, infants, and livergrown. Overlaid with these, he added to them deaths classed as smallpox, swinepox, measles, and worms without convulsions. Despite the crudity of this classification, his estimate of 36% mortality before the age of six years appears from later evidence to have been a good one. While three centuries have contributed to the scientific accuracy of disease classification, there are many who doubt the usefulness of attempts to compile statistics of disease, or even causes of death, because of the difficulties of classification. To these, one can quote Major Greenwood: '*The scientific purist, who will wait for medical statistics until they are nosologically exact, is no wiser than Horace's rustic waiting for the river to flow away*' (3).

Fortunately for the progress of preventive medicine, the General Register Office of England and Wales, at its inception in 1837, found in William Farr (1807-1883) – its first medical statistician. Farr was a man who not only made the best possible use of the imperfect classifications of disease available at the time but laboured to secure better classifications and international uniformity in their use.

Farr found Cullen's classification in use in the public services. It had not been revised to embody the advances in medical science, nor was it deemed by him to be satisfactory for statistical purposes. Farr realised that small numbers that would result from a detailed classification would not permit statistical inferences to be made. In the first Annual Report of the Registrar General (4), therefore, he discussed the principles that should govern a statistical classification of disease and urged the adoption of a uniform classification as follows:

\_The advantages of a uniform statistical nomenclature, however imperfect, are so obvious, that it is surprising no attention has been paid to its enforcement in Bills of Mortality. Each disease has, in many instances, been denoted by three or four terms, and each term has been applied to as many different diseases: vague, inconvenient names have been employed, or complications have been registered in

stead of primary diseases. The nomenclature is of as much importance in this department of inquiry as weights and measures in the physical sciences, and should be settled without delay.\_

Both nomenclature and statistical classification received constant study and consideration by Farr in his annual 'Letters' to the Registrar General published in the Annual Reports of the Registrar General. Farr did much to promote his classification but could not find general acceptance (4). However, the utility of a uniform classification of causes of death was so strongly recognised at the first International Statistical Congress, held in Brussels in 1853, that the Congress requested William Farr and Genevan Marc d'Espine to prepare an internationally applicable, uniform classification of causes of death.

At the next Congress, in Paris in 1855, Farr and d'Espine submitted two separate lists which were based on very different principles. Farr's classification was arranged under five groups: epidemic diseases, constitutional (general) diseases, local diseases arranged according to anatomical site, developmental diseases, and diseases that are the direct result of violence. D'Espine classified diseases according to their nature (gouty, herpetic, haematic, etc.). The Congress adopted a compromise list of 139 rubrics. In 1864, this classification was revised in Paris on the basis of Farr's model and was subsequently further revised in 1874, 1880, and 1886. Although this classification was never universally accepted, the general arrangement proposed by Farr, including the principle of classifying diseases by aetiology followed by anatomical site, survived as the basis of the International List of Causes of Death.

Importantly, the 1855 Congress also recommended that each country should ask for information on causes of death from the doctor who had been attending the deceased, and that each country should take measures to ensure that all deaths were verified by doctors (4).

### 3.13.2 Adoption of the International List of Causes of Death

At its 1891 meeting in Vienna, the International Statistical Institute, the successor to the International Statistical Congress, charged a committee chaired by Jacques Bertillon (1851-1922), Chief of Statistical Services of the City of Paris, with the preparation of a classification of causes of death. The committee's report was presented and adopted at the meeting of the International Statistical Institute in Chicago in 1893.

For main headings, Bertillon adopted the anatomical site rather than the nature of disease, according to Farr's plan. Bertillon's list included defined diseases most worthy of study by reason of their transmissible nature or their frequency of occurrence. In accordance with the instructions of the Vienna Congress, Bertillon included three classifications: an abridged classification of 44 titles; a classification of 99 titles; and a classification of 161 titles. Bertillon also prepared some rules or guidelines on the resolution of problems; for example, how statistical clerks should classify what is written without imputing what the doctor might have meant (5). The 'Bertillon Classification of Causes of Death', as it was first called, received general approval and was adopted by several countries, as well as by many cities. The classification was first used in North America by Jesus E. Monjaras for the statistics of San Luis de Potosi, Mexico (5). In 1898, the American Public Health Association, at its meeting in Ottawa, Canada, recommended the adoption of the Bertillon Classification by

registrars of Canada, Mexico, and the United States of America. The Association further suggested that the classification should be revised every ten years.

At the meeting of the International Statistical Institute at Christiania in 1899, Bertillon presented a report on the progress of the classification, including the recommendations of the American Public Health Association for decennial revisions. The International Statistical Institute then adopted the following resolution (6): The International Statistical Institute, convinced of the necessity of using comparable nomenclatures in the different countries:

\_Learns with pleasure of the adoption by all the statistical offices of North America, by some of those of South America, and by some in Europe, of the system of cause of death nomenclature presented in 1893; Insists vigorously that this system of nomenclature be adopted in principle and without revision, by all the statistical institutions of Europe; Approves, at least in its general lines, the system of decennial revision proposed by the American Public Health Association at its Ottawa session (1898); Urges the statistical offices who have not yet adhered, to do so without delay, and to contribute to the comparability of the cause of death nomenclature.\_

The French Government therefore assembled in Paris, in August 1900, the first International Conference for the Revision of the Bertillon or International List of Causes of Death. Delegates from 26 countries attended this Conference. A detailed classification of causes of death consisting of 179 groups and an abridged classification of 35 groups was adopted on 21 August 1900. The desire for decennial revisions was recognized, and the French Government was requested to call the next meeting in 1910. In fact, the next conference was held in 1909, and the Government of France called succeeding conferences in 1920, 1929, and 1938. Bertillon continued to be the guiding force in the promotion of the International List of Causes of Death, and the revisions of 1900, 1910, and 1920 were carried out under his leadership. As Secretary-General of the International Conference, he sent out the provisional revision for 1920 to more than 500 people, asking for comments. His death in 1922 left the International Conference without a guiding hand.

At the 1923 session of the International Statistical Institute, Michel Huber, Bertillon's successor in France, recognized this lack of leadership and introduced a resolution for the International Statistical Institute to renew its stand of 1893 in regard to the International Classification of Causes of Death and to cooperate with other international organisations in preparation for subsequent revisions. The Health organisation of the League of Nations had also taken an active interest in vital statistics and appointed a Commission of Statistical Experts to study the classification of diseases and causes of death, as well as other problems in the field of medical statistics. E. Roesle, Chief of the Medical Statistical Service of the German Health Bureau and a member of the Commission of Statistical Experts, prepared a monograph that listed the expansion in the rubrics of the 1920 International List of Causes of Death that would be required if the classification were to be used in the tabulation of statistics of morbidity. This careful study was published by the Health organisation of the League of Nations in 1928 (7). In order to coordinate the work of both agencies, an international 'Mixed Commission' was created with an equal number of representatives from the International Statistical Institute and the Health organisation of the League of

Nations. This Commission drafted the proposals for the Fourth (1929) and the Fifth (1938) revisions of the International List of Causes of Death.

### 3.13.3 The Fifth Decennial Revision Conference

The Fifth International Conference for the Revision of the International List of Causes of Death, like the preceding conferences, was convened by the Government of France and was held in Paris in October 1938. The Conference approved three lists: a detailed list of 200 titles, an intermediate list of 87 titles and an abridged list of 44 titles. Apart from bringing the lists up to date in accordance with the progress of science, particularly in the chapter on infectious and parasitic diseases, and changes in the chapters on puerperal conditions and on accidents, the Conference made as few changes as possible in the contents, number, and even in the numbering of the items. A list of causes of stillbirth was also drawn up and approved by the Conference.

As regards classification of diseases for morbidity statistics, the Conference recognised the growing need for a corresponding list of diseases to meet the statistical requirements of widely differing organisations, such as health insurance organisations, hospitals, military medical services, health administrations, and similar bodies. The following resolution, therefore, was adopted (8):

#### 3.13.3.1 International Lists of Diseases

- In view of the importance of the compilation of international lists of diseases corresponding to the international lists of causes of death: The Conference recommends that the Joint Committee appointed by the International Institute of Statistics and the Health organisation of the League of Nations undertake, as in 1929, the preparation of international lists of diseases, in conjunction with experts and representatives of the organisations specially concerned. Pending the compilation of international lists of diseases, the Conference recommends that the various national lists in use should, as far as possible, be brought into line with the detailed International List of Causes of Death (the numbers of the chapters, headings and subheadings in the said List being given in brackets). The Conference further recommended that the United States Government continue its studies of the statistical treatment of joint causes of death in the following resolution (9):
  - Death Certificate and Selection of Causes of Death where more than One Cause is given (Joint Causes) The Conference,
    - Whereas, in 1929, the United States Government was good enough to undertake the study of the means of unifying the methods of selection of the main cause of death to be tabulated in those cases where two or more causes are mentioned on the death certificate,
    - And whereas, the numerous surveys completed or in the course of preparation in several countries reveal the importance of this problem, which has not yet been solved,
    - And whereas, according to these surveys, the international comparability of death rates from the various diseases requires, not only the solution of the problem of the selection of the main

tabulated cause of death, but also the solution of several other questions;

- Warmly thanks the United States Government for the work it has accomplished or promoted in this connection;
- Requests the United States Government to continue its investigations during the next ten years, in cooperation with other countries and organisations, on a slightly wider basis, and
- Suggests that, for these future investigations, the United States Government should set up a subcommittee comprising representatives of countries and organisations participating in the investigations undertaken in this connection.

#### 3.13.4 Previous classifications of diseases for morbidity statistics

In the discussion so far, classification of disease has been presented almost wholly in relation to cause-of-death statistics. Farr, however, recognized that it was desirable “to extend the same system of nomenclature to diseases which, though not fatal, cause disability in the population, and now figure in the tables of the diseases of armies, navies, hospitals, prisons, lunatic asylums, public institutions of every kind, and sickness societies, as well as in the census of countries like Ireland, where the diseases of all the people are enumerated” (10). In his *‘Report on nomenclature and statistical classification of diseases’*, presented to the Second International Statistical Congress, he therefore included in the general list of diseases most of those diseases that affect health as well as diseases that are fatal. At the Fourth International Statistical Congress, held in London in 1860, Florence Nightingale urged the adoption of Farr’s classification of diseases for the tabulation of hospital morbidity in the paper, *‘Proposals for a uniform plan of hospital statistics’*.

At the First International Conference to revise the Bertillon Classification of Causes of Death in Paris in 1900, a parallel classification of diseases for use in statistics of sickness was adopted. A parallel list was also adopted at the second conference in 1909. The extra categories for non-fatal diseases were formed by subdivision of certain rubrics of the cause-of-death classification into two or three disease groups, each of these being designated by a letter. The translation in English of the Second Decennial Revision, published by the United States Department of Commerce and Labor in 1910, was entitled International Classification of Causes of Sickness and Death. Later revisions incorporated some of the groups into the detailed International List of Causes of Death. The Fourth International Conference adopted a classification of illness which differed from the detailed International List of Causes of Death only by the addition of further subdivisions of 12 titles. These international classifications of illnesses, however, failed to receive general acceptance, as they provided only a limited expansion of the basic cause-of-death list.

In the absence of a uniform classification of diseases that could be used satisfactorily for statistics of illness, many countries found it necessary to prepare their own lists. A Standard Morbidity Code was prepared by the Dominion Council of Health of Canada and published in 1936. The main subdivisions of this code represented the 18 chapters of the 1929 Revision of the International List of Causes of Death, and these were subdivided into some 380 specific disease categories. At the Fifth International Conference in 1938, the Canadian delegate introduced a modification of this list for consideration as the basis for an international list of causes of illness. Although no action was taken on this proposal, the Conference adopted the resolution quoted above.

In 1944, provisional classifications of diseases and injuries were published in both the United Kingdom and the United States for use in the tabulation of morbidity statistics. Both classifications were more extensive than the Canadian list, but, like it, followed the general order of diseases in the International List of Causes of Death. The British classification was prepared by the Committee on Hospital Morbidity Statistics of the Medical Research Council, which was created in January 1942. It is entitled '*A provisional classification of diseases and injuries for use in compiling morbidity statistics*' (8). It was prepared with the purpose of providing a scheme for collecting and recording statistics of patients admitted to hospitals in the United Kingdom, using a standard classification of diseases and injuries, and was used throughout the country by governmental and other agencies.

A few years earlier, in August 1940, the Surgeon-General of the United States Public Health Service and the Director of the United States Bureau of the Census published a list of diseases and injuries for tabulation of morbidity statistics (9). The code was prepared by the Division of Public Health Methods of the Public Health Service in cooperation with a committee of consultants appointed by the Surgeon-General. '*The Manual for coding causes of illness according to a diagnosis code for tabulating morbidity statistics*', consisting of the diagnosis code, a tabular list of inclusions, and an alphabetical index, was published in 1944. The code was used in several hospitals, in a large number of voluntary hospital insurance plans and medical care plans, and in special studies by other agencies in the United States.

### 3.13.5 United States Committee on Joint Causes of Death

In compliance with the resolution of the Fifth International Conference, the American Secretary of State in 1945 appointed the United States Committee on Joint Causes of Death under the chairmanship of Lowell J. Reed, Professor of Biostatistics at Johns Hopkins University. Members and consultants of this committee included representatives of the Governments of Canada and the United Kingdom and the Health Section of the League of Nations. Recognizing a trend, the committee decided that it would be advantageous to consider classifications from the point of view of morbidity and mortality, since the problem of joint causes pertained to both types of statistics.

The committee also took into account that part of the resolution on International Lists of Diseases of the previous International Conference recommending that the 'various national lists in use should, as far as possible, be brought into line with the detailed International List of Causes of Death'. It recognized that the classification of sickness and injury is closely linked with the classification of causes of death. The view that such lists are fundamentally different arises from the erroneous belief that the International List is a classification of terminal causes, whereas it is in fact based upon the morbid condition that initiated the train of events ultimately resulting in death. The committee believed that, in order to utilise fully both morbidity and mortality statistics, not only should the classification of diseases for both purposes be comparable, but if possible, there should be a single list.

Furthermore, an increasing number of statistical organisations were using medical records involving both sickness and death. Even in organisations that compile only morbidity statistics, fatal as well as non-fatal cases needed to be coded. A single list, therefore, greatly facilitates their coding operations. It also provides a common base for comparison of morbidity and mortality statistics.



A subcommittee was therefore appointed, which prepared a draft of a Proposed Statistical Classification of Diseases, Injuries and Causes of Death. A final draft was adopted by the committee after it had been modified on the basis of trials undertaken by various agencies in Canada, the United Kingdom and the United States of America.

**Table 1:** *ICD Revisions under the auspices of WHO*

<b>Revision</b>	<b>Date of coming into effect</b>	<b>Year of WHA adoption</b>
6th Revision	1948	1948 (WHA1.36)
7th Revision	1 Jan 1958	May 1956 (WHA9.29)
8th Revision	1 Jan 1968	May 1966 (WHA19.44)
9th Revision	1 Jan 1979	May 1976 (WHA29.34)
10th Revision	1 Jan 1993	May 1990 (WHA43.24)
11th Revision	1 Jan 2022	May 2019 (WHA72.15)

### 3.13.6 Sixth Revision of the International Lists

The International Health Conference held in New York City in June and July 1946 (11) entrusted the Interim Commission of the World Health Organisation with the responsibility of 'reviewing the existing machinery and of undertaking such preparatory work as may be necessary in connection with: (i) the next decennial revision of 'The International Lists of Causes of Death' (including the lists adopted under the International Agreement of 1934, relating to Statistics of Causes of Death); and (ii) the establishment of International Lists of Causes of Morbidity.'

To meet this responsibility, the Interim Commission appointed the Expert Committee for the Preparation of the Sixth Decennial Revision of the International Lists of Diseases and Causes of Death. This Committee, taking full account of prevailing opinion concerning morbidity and mortality classification, reviewed and revised the above-mentioned proposed classification which had been prepared by the United States Committee on Joint Causes of Death.

The resulting classification was circulated to national governments preparing morbidity and mortality statistics for comments and suggestions under the title, International Classification of Diseases, Injuries, and Causes of Death. The Expert Committee considered the replies and prepared a revised version incorporating changes to improve the utility and acceptability of the classification. The Committee also compiled a list of diagnostic terms to appear under each title of the classification. Furthermore, a subcommittee was appointed to prepare a comprehensive alphabetical index of diagnostic statements classified to the appropriate category of the classification. The Committee also considered the structure and uses of special lists of causes for tabulation and publication of morbidity and mortality statistics and studied other problems related to the international comparability of mortality statistics, such as form of medical certificate and rules for classification. The International Conference for the Sixth Revision of the International Lists of Diseases and Causes of Death was convened in Paris from 26 to 30 April 1948 by the Government of France under the terms of the agreement signed at the close of the Fifth Revision Conference in 1938. Its secretariat was entrusted jointly to the competent French authorities and to the World Health Organisation, which had carried out the preparatory work under the terms of the

arrangement concluded by the governments represented at the International Health Conference in 1946 (12).

The Conference adopted the classification prepared by the Expert Committee as the Sixth Revision of the International Lists (13). It also considered other proposals of the Expert Committee concerning the compilation, tabulation and publication of morbidity and mortality statistics. The Conference approved the International Form of Medical Certificate of Cause of Death, accepted the underlying cause of death as the main cause to be tabulated, and endorsed the rules for selecting the underlying cause of death as well as the special lists for tabulation of morbidity and mortality data. It further recommended that the World Health Assembly should adopt regulations under Article 21(b) of the WHO Constitution to guide Member States in compiling morbidity and mortality statistics in accordance with the International Statistical Classification. In 1948, the First World Health Assembly endorsed the report of the Sixth Revision Conference and adopted World Health Organisation Regulations No. 1, devised based on the recommendations of the Conference. The International Classification, including the Tabular List of Inclusions defining the content of the categories, was incorporated, together with the form of the medical certificate of cause of death, the rules for classification and the special lists for tabulation, into the Manual of the International Statistical Classification of Diseases, Injuries, and Causes of Death (22). The Manual consisted of two volumes, Volume 2 being an alphabetical index of diagnostic terms coded to the appropriate categories. In the Sixth Revision, morbid conditions resulting from injuries, poisonings and other external causes were classified according to both the external circumstances giving rise to the injury and to the kind of injury.

The adoption of this dual classification was regarded at the time as a bold step to deal with the simultaneous interest in more than one aspect of injury. The Sixth Decennial Revision Conference marked the beginning of a new era in international vital and health statistics. Apart from approving a comprehensive list for both mortality and morbidity and agreeing on international rules for selecting the underlying cause of death, it recommended the adoption of a comprehensive programme of international cooperation in the field of vital and health statistics. An important item in this programme was the recommendation that governments establish national committees on vital and health statistics to coordinate the statistical activities in the country, and to serve as a link between the national statistical institutions and the World Health Organisation. It was further envisaged that such national committees would, either singly or in cooperation with other national committees, study statistical problems of public health importance and make the results of their investigations available to the WHO.

### 3.13.7 The Seventh and Eighth Revisions

The International Conference for the Seventh Revision of the International Classification of Diseases was held in Paris under the auspices of the WHO in February 1955 (14). In accordance with a recommendation of the WHO Expert Committee on Health Statistics, this revision was limited to essential changes and amendments of errors and inconsistencies (15). The Eighth Revision Conference convened by the WHO met in Geneva, from 6 to 12 July 1965 (16). This revision was more radical than the Seventh but left unchanged the basic structure of the Classification and the general philosophy of classifying diseases, whenever possible, according to their aetiology rather than a particular manifestation. During the

years that the Seventh and Eighth Revisions of the ICD were in force, the use of the ICD for indexing hospital medical records increased rapidly and some countries prepared national adaptations which provided the additional detail needed for this application of the ICD.

### 3.13.8 The Ninth Revision

The International Conference for the Ninth Revision of the International Classification of Diseases, convened by the WHO, met in Geneva from 30 September to 6 October 1975 (17). In the discussions leading up to the conference, it had originally been intended that there should be little change other than updating of the classification. This was mainly because of the expense of adapting data processing systems each time the classification was revised. There had been an enormous growth of interest in the ICD and ways had to be found of responding to this, partly by modifying the classification itself and partly by introducing special coding provisions.

A number of representations were made by specialist bodies which had become interested in using the ICD for their own statistics. Some subject areas in the classification were regarded as inappropriately arranged and there was considerable pressure for more detail and for adaptation of the classification to make it more relevant for the evaluation of medical care, by classifying conditions to the chapters concerned with the part of the body affected rather than to those dealing with the underlying generalised disease. At the other end of the scale, there were representations from countries and areas where a detailed and sophisticated classification was irrelevant, but which nevertheless needed a classification based on the ICD in order to assess their progress in health care and in the control of disease. The final proposals presented to and accepted by the Conference retained the basic structure of the ICD, although with much additional detail at the level of the four-digit subcategories, and some optional five-digit subdivisions. For the benefit of users not requiring such detail, care was taken to ensure that the categories at the three-digit level were appropriate.

For the benefit of users wishing to produce statistics and indexes oriented towards medical care, the Ninth Revision included an optional alternative method of classifying diagnostic statements, including information about both an underlying general disease and a manifestation in a particular organ or site. This system became known as the dagger and asterisk system. The Twenty Ninth World Health Assembly, noting the recommendations of the International Conference for the Ninth Revision of the International Classification of Diseases, approved the publication, for trial purposes, of supplementary classifications of Impairments and Handicaps and of Procedures in Medicine as supplements to, but not as integral parts of, the International Classification of Diseases.

### 3.13.9 The Tenth Revision

Even before the Conference for the Ninth Revision, the WHO had been preparing for the Tenth Revision. It recognised that the great expansion in the use of the ICD necessitated a thorough rethinking of its structure and an effort to devise a stable and flexible classification, which should not require fundamental revision for many years to come. The WHO Collaborating Centres for Classification of Diseases (see [www.who.int/classification](http://www.who.int/classification)) were consequently called upon to experiment with models of alternative structures for ICD-10.

It had also become clear that the established ten-year interval between revisions was too short. Work on the revision process had to start before the current version of the ICD had been in use long enough to be thoroughly evaluated, mainly because the necessity to consult so many countries and organisations made the process a very lengthy one. The Director General of the WHO therefore wrote to the Member States and obtained their agreement to postpone a 1985 Tenth Revision Conference until 1989, and to delay the introduction of the Tenth Revision which would have been due in 1989. In addition to permitting experimentation with alternative models for the structure of the ICD, this allowed time for the evaluation of ICD-9, for example through meetings organised by some of the WHO Regional Offices and through a survey organised at headquarters.

The International Conference for the Tenth Revision of the International Classification of Diseases, attended by delegates from 43 Member States, was convened by the World Health Organisation in Geneva from 26 September to 2 October 1989. The United Nations, the International Labour Organisation, and the WHO Regional Offices sent representatives to participate in the Conference, as did the Council for International organisations of Medical Sciences. Twelve other non-governmental organisations concerned with cancer registration, the deaf, epidemiology, family medicine, gynaecology and obstetrics, hypertension, health records, preventive and social medicine, neurology, psychiatry, rehabilitation and sexually transmitted diseases were also invited.

Extensive preparatory activity had been devoted to a radical review of the suitability of the structure of the ICD, essentially a statistical classification of diseases and other health problems, to serve a wide variety of needs for mortality and health care data. Ways of stabilizing the coding system to minimize disruption at successive revisions had been investigated, as had the possibility of providing a better balance between the content of the different chapters of the ICD. Even with a new structure, it was plain that one classification could not cope with the extremes of the requirements. The concept had therefore been developed of a 'family' of classifications, which would include the ICD for traditional mortality and morbidity statistics, while needs for more detailed, less detailed or different classifications and associated matters would be dealt with by other members of the family. The potential for different members of the 'family' in the medico-social and multi-dimensional assessment in relation not only to health but also to activities of daily living, as well as the social and physical environment, was recognised. It was demonstrated that effective information could be obtained through use of the ICD and the International Classification of Impairments, Disabilities, and Handicaps (ICIDH) (18), and through use of the codes from Chapter XXI of the Tenth Revision.

The main innovation in the Tenth Revision was the use of an alphanumeric coding scheme of one letter followed by three numbers at the four-character level. This had the effect of more than doubling the size of the coding frame in comparison with the Ninth Revision and enabled the vast majority of chapters to be assigned a unique letter or group of letters, each capable of providing 100 three-character categories. Of the 26 available letters, 25 had been used, the letter U being left vacant for future additions and changes, and for possible interim classifications to solve difficulties arising at the national and international level between revisions.

Another important innovation was the creation towards the end of certain chapters of categories for postprocedural disorders. These identified important conditions that

constituted a medical care problem in their own right. Postprocedural conditions that were not specific to a particular body system continued to be classified in the chapter on 'Injury, poisoning and certain other consequences of external causes'. The Revision included definitions, standards, and reporting requirements related to maternal mortality and to fetal, perinatal, neonatal and infant mortality. It was published in three volumes: one containing the Tabular List, a second containing all related definitions, standards, rules and instructions, and a third containing the Alphabetical Index.

The Tenth Revision Conference discussed the difficulties experienced during the extended period of use of the Ninth Revision, related to the emergence of new diseases and the lack of an updating mechanism to accommodate them. It recognised that it would not be feasible to hold revision conferences more frequently than every 10 years. It also recognised that any changes introduced during the lifetime of the Tenth Revision would need to be considered carefully in relation to their impact on analyses and trends.

### 3.13.10 The WHO Family of International Classifications

Although the ICD is suitable for many different applications, it does not serve all the needs of its various users. It does not provide sufficient detail for some specialties and sometimes information on different attributes of health conditions may be needed. Also, the ICD is not useful to describe functioning and disability as aspects of health and does not include a full array of health interventions or reasons for encounter. Foundations laid by the International Conference on ICD-10 in 1989 provided the basis for the development of a 'family' of health classifications. This was given added momentum during the 1990s by the development of the International Classification of Functioning, Disability and Health (ICF) (19), approved by the World Health Assembly in 2001.

In 2001, the WHO Family of International Classifications (WHO-FIC) was created. At the core of the Family are its reference classifications, currently the ICD and the ICF; the International Classification of Health Interventions (ICHI), now under development, is the third reference classification. The WHO-FIC also includes derived classifications, which provide additional detail to core classifications or are rearrangements or aggregations of terms in core classifications; the WHO has licensed several countries to develop national modifications of the ICD as derived classifications. As well, the WHO-FIC includes related classifications to cover health functions which are not (or are only partially) covered by other WHO-FIC members. The WHO-FIC is supported by a network of Collaborating Centres, based on the former Collaborating Centres for the ICD and the ICF, but continuously expanded by the addition of new centres.

#### **Table 2:** *Evolution of ICD*

<b>Iteration</b>	<b>Year</b>	<b>Document</b>	<b>Note</b>
0	1891	Bertillon Classification of Causes of Death	Drafted by International Statistical Institute
1	1900	Bertillon/International List of Causes of Death	First International Conference for Revision of List of Causes of Death
2	1910	International List of Causes of Death	179 titles, call for revision every 10 years
3	1920	International List of Causes of Death	
4	1929	International List of Causes of Death	Drafted jointly by International Statistical Institute and Health organisation of the League of Nations
5	1938	International List of Causes of Death	200 titles, additions to infectious and parasitic
6	1948	International Classification of Diseases, Injuries, and Causes of Death	Recognition of classification of disease and injury, in addition to causes of death
7	1955	International Classification of Diseases, Injuries, and Causes of Death	
8	1965	International Classification of Diseases, Injuries, and Causes of Death	
9	1976	International Classification of Diseases, Injuries, and Causes of Death	Trial of supplement on Impairments and Handicaps, and Procedures in Medicine
10	1990	International Statistical Classification of Diseases and Related Health Problems	Introduction of alpha-numeric coding scheme, postprocedural disorders; regular interim updates
11	2019	International Statistical Classification of Diseases and Related Health Problems	Postcoordination (cluster coding); addition of Traditional Medicine, adverse events coding

### 3.13.11 Updating of ICD between revisions

As foreshadowed at the Tenth Revision conference, updating of the tenth revision of ICD commenced in 2000. Updating proposals came from, and were carefully considered by, the WHO and Collaborating Centres, including the impact on trends. The updating process has allowed an extended life for the Tenth Revision while maintaining its clinical and scientific currency.

### 3.13.12 Major Steps in the ICD-11 Revision

The revision of ICD-11 has taken place in several phases. First; a list of issues that were known from the use of ICD-10 and that could not be solved in its classification structure was

compiled and possible solutions were formulated. Second; input was received from many scientific groups in the key subject areas, with a focus on clinical perspectives. Finally, centralised editing occurred, aimed at adjusting imbalances in content generated by multiple, independently operating expert groups in the previous phase of the revision, and at ensuring consistency and practicability of the overall structure for mortality and morbidity statistics.

The final version also received input from field testing, Member State comments, and ongoing submissions and processing of proposals.

### 3.13.13 Preparations for the Eleventh Revision

By 2003, it was becoming clear to the WHO and the Collaborating Centres that a further revision of the ICD could no longer be delayed. The extent to which ICD updating could encapsulate emerging developments was limited by the structure of ICD–10, and some issues needed extended development and discussion with expert groups. A special meeting of Collaborating Centres in Helsinki in 2004 discussed the need for a revision and issues to be addressed as part of the revision process. The 2004 WHO-FIC meeting subsequently adopted a revision process work-plan which was progressively developed at ensuing meetings.

In 2007, the WHO formally launched the revision process. Oversight has been provided through a broad-based Revision Steering Group. Technical work has been undertaken by a series of Topic Advisory Groups, with cross-cutting groups examining mortality, morbidity and quality and safety issues. For the first time, a chapter on description of diseases and patterns of diseases from a traditional medicine standpoint has been included.

A Content Model, including a range of components for each ICD entity has been developed, giving a rich foundation for the ICD. Other classifications and terminologies are linked or included where possible to ensure ICD is aligned with them, and items used in other members of the WHO Family of Classifications have been aligned wherever possible. The more traditional statistical classification for mortality and morbidity is obtained from the Foundation Component of ICD–11 as a tabular list. Extension codes are used to limit content volume but still allow detailed classification of disease entities. Supplementary chapters and sections allow capturing on an optional basis information about traditional medicine diagnoses and functioning. Based on the experiences with ICD-9 and ICD-10 an updating mechanism was designed, that allows improvements in user guidance and scientific updates without compromising the statistical use of the classification.

### 3.13.14 References for history of ICD

1. Knibbs G.H. The International Classification of Disease and Causes of Death and its revision. *Medical journal of Australia*, 1929, 1:2-12.
2. Moriyama IM, Loy RM, Robb-Smith AHT. History of the statistical classification of diseases and causes of death. Rosenberg HM, Hoyert DL, eds. Hyattsville, MD: National Center for Health Statistics. 2011.
3. Greenwood M. *Medical statistics from Graunt to Farr*. Cambridge, Cambridge University Press, 1948.
4. First annual report. London, Registrar General of England and Wales, 1839, p. 99.
5. Bertillon J. Classification of the causes of death (abstract). In: *Transactions of the 15th International Congress on Hygiene Demography*. Washington, 1912.
6. International list of causes of death. The Hague, International Statistical Institute, 1940.
7. Roesle E. *Essai d'une statistique comparative de la morbidité devant servir à établir les listes spéciales des causes de morbidité*. Geneva, League of Nations Health organisation, 1928 (document C.H. 730)
8. Medical Research Council, Committee on Hospital Morbidity Statistics. *A provisional classification of diseases and injuries for use in compiling morbidity statistics*. London, Her Majesty's Stationery Office, 1944 (Special Report Series No. 248).
9. US Public Health Service, Division of Public Health Methods. *Manual for coding causes of illness according to a diagnosis code for tabulating morbidity statistics*. Washington, Government Publishing Office, 1944 (Miscellaneous Publication No. 32).
10. Sixteenth annual report. London, Registrar General of England and Wales, 1856, App. p.73.
11. *Official Records of the World Health Organisation*, 1948, 11, 23.
12. *Official Records of the World Health Organisation*, 1948, 2, 110.
13. *Manual of the international statistical classification of diseases, injuries, and causes of death*. Sixth revision. Geneva, World Health Organisation, 1949.
14. *Report of the International Conference for the Seventh Revision of the International Lists of Diseases and Causes of Death*. Geneva, World Health Organisation, 1955 (unpublished document WHO/HA/7 Rev. Conf./17 Rev. 1).
15. *Third Report of the Expert Committee on Health Statistics*. Geneva, World Health organisation, 1952 (WHO Technical Report Series, No. 53).
16. *Report of the International Conference for the Eighth Revision of the International Classification of Diseases*. Geneva, World Health Organisation, 1965 (unpublished document WHO/ICD9/74.4).
17. *Manual of the international statistical classification of diseases, injuries, and causes of death*, Volume 1. Geneva, World Health Organisation, 1977.
18. *International Classification of Impairments, Disabilities, and Handicaps*. Geneva, World Health Organisation, 1980.
19. *International Classification of Functioning, Disability and Health*. Geneva, World Health organisation, 2001
20. *Eleventh revision of the International Classification of Diseases*, Report by the Director-General, 2019, [https://apps.who.int/gb/ebwha/pdf\\_files/WHA72/A72\\_29Add1-en.pdf](https://apps.who.int/gb/ebwha/pdf_files/WHA72/A72_29Add1-en.pdf)



## 3.14 Annex C: Annexes for Mortality Coding

### 3.14.1 International form of medical certificate of cause of death

<b>Administrative Data</b> (can be further specified by country)																			
Sex	<input type="checkbox"/> Female				<input type="checkbox"/> Male				<input type="checkbox"/> Unknown										
Date of birth	D	D	M	M	Y	Y	Y	Y	Date of death	D	D	M	M	Y	Y	Y	Y		
<b>Frame A: Medical data: Part 1 and 2</b>																			
<b>1</b> Report disease or condition directly leading to death on line a  Report chain of events in due to order (if applicable)  State the underlying cause on the lowest used line			Cause of death	Time interval from onset to death															
		a																	
		b	Due to:																
		c	Due to:																
		d	Due to:																
<b>2</b> Other significant conditions contributing to death (time intervals can be included in brackets after the condition)			-----																
<b>Frame B: Other medical data</b>																			
Was <b>surgery</b> performed within the last 4 weeks?										<input type="checkbox"/> Yes			<input type="checkbox"/> No		<input type="checkbox"/> Unknown				
If yes please specify date of surgery										D	D	M	M	Y	Y	Y	Y		
If yes please specify reason for surgery (disease or condition)																			
Was an autopsy requested?										<input type="checkbox"/> Yes		<input type="checkbox"/> No		<input type="checkbox"/> Unknown					
If yes were the findings used in the certification?										<input type="checkbox"/> Yes		<input type="checkbox"/> No		<input type="checkbox"/> Unknown					
<b>Manner of death:</b>																			
<input type="checkbox"/> Disease				<input type="checkbox"/> Assault				<input type="checkbox"/> Could not be determined											
<input type="checkbox"/> Accident				<input type="checkbox"/> Legal intervention				<input type="checkbox"/> Pending investigation											
<input type="checkbox"/> Intentional self harm				<input type="checkbox"/> War				<input type="checkbox"/> Unknown											
If external cause or poisoning:										Date of injury		D	D	M	M	Y	Y	Y	Y
Please describe how external cause occurred (If poisoning please specify poisoning agent)																			
<b>Place of occurrence of the external cause:</b>																			
<input type="checkbox"/> At home			<input type="checkbox"/> Residential institution			<input type="checkbox"/> School, other institution, public administrative area				<input type="checkbox"/> Sports and athletics area									
<input type="checkbox"/> Street and highway			<input type="checkbox"/> Trade and service area			<input type="checkbox"/> Industrial and construction area				<input type="checkbox"/> Farm									
<input type="checkbox"/> Other place (please specify):										<input type="checkbox"/> Unknown									
<b>Fetal or infant Death</b>																			
Multiple pregnancy										<input type="checkbox"/> Yes		<input type="checkbox"/> No		<input type="checkbox"/> Unknown					
Stillborn?										<input type="checkbox"/> Yes		<input type="checkbox"/> No		<input type="checkbox"/> Unknown					
If death within 24h specify number of hours survived										Birth weight (in grams)									
Number of completed weeks of pregnancy										Age of mother (years)									
If death was perinatal, please state conditions of mother that affected the fetus and newborn																			
<b>For women, was the deceased pregnant?</b>																			
<input type="checkbox"/> At time of death										<input type="checkbox"/> Within 42 days before the death									
<input type="checkbox"/> Between 43 days up to 1 year before death										<input type="checkbox"/> Unknown									
Did the pregnancy contribute to the death?										<input type="checkbox"/> Yes		<input type="checkbox"/> No		<input type="checkbox"/> Unknown					

### The International Form of Medical Certificate of Cause of Death

Additional data that might be necessary for the reporting system of countries can be added to the certificate. The form has a Frame A that serves to report the cause(s) of death, the sequence of causes, the duration of diseases until death, and other conditions contributing to death. Causes of death should be reported with the best available detail. For example, 'birth depression' for a newborn child that died, should be complemented by the reason for the birth depression, as intrapartum asphyxia, or prepartum hypoxaemia.

The Frame B is designed to help to report detail that is relevant to coding and epidemiology analyses for deaths due to external causes, maternal deaths, perinatal deaths, and deaths due to postprocedural conditions. It complements the information in Frame A. The complete reporting of the causes of death is based on an accurate examination of the dead body, the assessment of local circumstances and insight available from health records. Correct establishment of a cause of death and completion of the death certificate requires training that should start at medical school and be refreshed in regular education programmes. Also important is the practical experience in death certification that is gained under the supervision of more experienced colleagues. It is noted that medical certifiers that establish the cause of death may not always be available. Certification by non-physicians may result in a changed pattern of the reported causes of death.

Where the dead body is no longer available for examination, for example due to low coverage of medical staff or traditional rapid burial procedures, a verbal autopsy may provide some limited information on the cause of death. In such a case, a sequence of causes that led to death will rarely be identified, and causes identified with verbal autopsy should be reported separately to those available from formal death certification process.

### 3.14.2 Quick reference guide for the International form of medical certificate of cause of death (MCCD flyer)

Cause of death information serves

- epidemiology and prevention
- managing health care
- comparing health in different populations

Certification of death is one of the first steps in getting an overview of the health of people. The diseases or conditions recorded on a death certificate represent the best medical opinion. A properly completed cause-of-death certificate provides a description of the order, type and association of events that have resulted in the death. The diagnoses reported on the certificate are coded with the International Classification of Diseases. The filling in of the cause-of-death certificate is independent of the revision of ICD. This coded data is analyzed and used both nationally and internationally no matter what language was used to complete the certification.

#### **Cause of Death on the certificate - how to fill in?**

**Frame A:** Death certificates may look different in most countries. But the section on the cause of death is identical worldwide. Frame A has two parts, called Part 1 and Part 2, and a section to record the time interval between the onset of each condition and the date of death.

**Part 1** - is used for diseases or conditions that form part of the **sequence of events** leading directly to death. The immediate (direct) cause of death is entered on the first line, 1(a).

There must always be an entry on line 1(a). The entry on line 1(a) may be the only condition reported in Part I of the certificate. Where there are **two or more conditions** that form part of the sequence of events leading directly to death, each event in the sequence should be recorded on a separate line.

In any case you must record the disease, injury or external cause that resulted in the death. Do not record only the **mode of dying**, such as cardiac arrest, respiratory failure or heart failure.

Try to be as specific as you can. **“Unknown”** cause of death should be recorded in cases where thorough testing or autopsy examination the cause of death cannot be determined. Stating “Unknown” is better than any speculation on the possible cause of death.

Always fully spell out all terms. **Abbreviations** can be interpreted in different ways. Terms such as “suspected” or “possible” are ignored in evaluation of the entries. For example “suspected Diabetes” will be interpreted as “Diabetes”. The four lines may not provide enough space for the chain of events. Do not waste space with **unnecessary words**. Some clinical terms are very vague. For example, “tumour” does not specify behaviour (see also last page of this flyer).

**Duration** - is the time interval between the onset of each condition that is entered on the certificate (not the time of diagnosis of the condition), and the date of death. The duration information is useful in coding certain diseases and also provides a useful check on the order of the reported sequence of conditions.

**Part 2** - is used for conditions that do not belong in Part 1 but their presence contributed to death.

**Frame B:** Some detail is frequently forgotten in Part 1 and 2 (Frame A). Separate detailed questions ask for detail such as previous surgery, mode of death or place of occurrence. Frame B is not shown in this information sheet. It is self-explanatory.

### **Cause of Death on the certificate - step by step**

- **Start** at line 1(a), with the immediate (direct) cause, then go back in time to preceding conditions until you get to the one that started the sequence of events. You will get very close to the time the patient was healthy.
- **Now**, you should have reported the underlying or originating cause on the lowest used line and a sequence of events leads from the underlying cause up to the immediate (direct) cause in the first line 1(a).
- **Finally**, record the time interval between the onset of each condition entered on the certificate and the date of death. Where the time or date of onset is not known you

should record a best estimate. Enter the unit of time (minutes, hours, days, weeks, months, years).

## Example

Frame A: Medical data: Part 1 and 2			
<b>1</b> Report disease or condition directly leading to death on line a  Report chain of events in due to order (if applicable)  State the underlying cause on the lowest used line		<b>Cause of death</b>	<b>Time interval from onset to death</b>
	<b>a</b>	Cerebral haemorrhage	4 hours
	<b>b</b>	Due to: Metastasis to the brain	4 months
	<b>c</b>	Due to: Breast cancer	5 years
	<b>d</b>	Due to:	
<b>2</b> Other significant conditions contributing to death (time intervals can be included in brackets after the condition)			

### Example

- **Write clearly** and do not use abbreviations.
- Be sure the information is **complete**.
- **Do not speculate** on the cause of death.
- Do not fill in laboratory results or statements like “found by partner” (there may be separate fields on the form for this kind of information).
- One condition per line should be sufficient.

### Frequently used ill-defined terms

<b>Term</b>	<b>Instruction</b>
<b>Accident</b>	Specify <b>circumstances</b> . Specify <b>intent</b> , as car accident, suicidal, or assault. Specify <b>place</b> of occurrence.
<b>Alcohol, drugs</b>	Specify <b>use</b> : long term or single, addiction
<b>Complication of surgery</b>	Specify <b>disease</b> that was the reason for surgery
<b>Dementia</b>	Specify <b>cause</b> : e.g. due to Alzheimer disease, cerebrovascular, Lewy body
<b>Hepatitis</b>	Specify <b>course, etiology</b> : acute or chronic, alcoholic. If viral (specify type A, B, C..)
<b>Infarction</b>	Specify <b>site</b> : heart, brain... Specify <b>cause</b> : arteriosclerotic, thrombotic, embolic
<b>Infection</b>	Specify: primary or secondary, causative <b>organism</b> . If <b>primary</b> : specify bacterial, viral, fungal or parasitic. If <b>secondary</b> : specify the primary infection
<b>Leukaemia</b>	Specify: <b>type</b> e.g. myeloid, monocytic, lymphoid, also whether acute or chronic
<b>Pneumonia</b>	Specify: primary, aspiration, <b>cause</b> , causative <b>organism</b> . If due to immobility: specify the cause of immobility
<b>Pulmonary embolism</b>	Specify <b>cause</b> of embolism. If <b>postsurgical</b> or due to <b>immobility</b> , indicate the disease that was a cause for surgery or of immobility
<b>Renal failure</b>	Specify: acute, chronic or terminal, underlying <b>cause</b> of insufficiency, such as arteriosclerosis or infection. If due to immobility: specify the cause of immobility
<b>Thrombosis</b>	Specify: arterial or venous. Specify: the blood vessel. If postsurgical or immobility: specify disease that was a cause for surgery or immobility
<b>Tumour</b>	Specify: behaviour, location, metastases
<b>Urinary tract infection</b>	Specify: site in the urinary tract, causative <b>organism</b> , underlying <b>cause</b> of infection. If due to immobility: specify the cause of immobility

### 3.14.3 Suggested additional details of perinatal deaths

Identifying particulars														
Child was born live on				D	D	M	M	Y	Y	at hh:mm		hours		
Child was stillborn on				D	D	M	M	Y	Y	at hh:mm		hours		
<input type="checkbox"/> Died before labour				<input type="checkbox"/> During labour				<input type="checkbox"/> Not known						
Mother														
Date of birth			D	D	M	M	Y	Y						
<b>Number of previous pregnancies</b>						<b>Date of last pregnancy</b>			D	D	M	M	Y	Y
Live birth _____						<b>Outcome of last previous pregnancy</b>								
Stillbirth _____						<input type="checkbox"/> Live birth								
Abortion _____						<input type="checkbox"/> Stillbirth								
						<input type="checkbox"/> Abortion								
1st day of last menstrual period				D	D	M	M	Y	Y					
<b>Delivery</b>						<b>Antenatal care, two or more visits</b>								
<input type="checkbox"/> Normal spontaneous vertex						<input type="checkbox"/> Yes								
<input type="checkbox"/> Other (specify) _____						<input type="checkbox"/> No								
						<input type="checkbox"/> Not known								
Attendant at birth														
<input type="checkbox"/> Physician				<input type="checkbox"/> Other trained person (specify) _____										
<input type="checkbox"/> Trained midwife				<input type="checkbox"/> Other (specify) _____										
Child														
<input type="checkbox"/> Single birth				<input type="checkbox"/> Second twin										
<input type="checkbox"/> First twin				<input type="checkbox"/> Other multiple (specify) _____										

*Suggested Additional Details Perinatal Deaths*

Workflow diagram of steps SP1 to SP8, and to Steps M1 to M4 for mortality coding.

First assign ICD codes to all conditions mentioned on the death certificate see Section 'Coding Instructions for mortality: multiple causes'

**Workflow diagram of the application of the coding instruction for the selection of underlying cause of death**

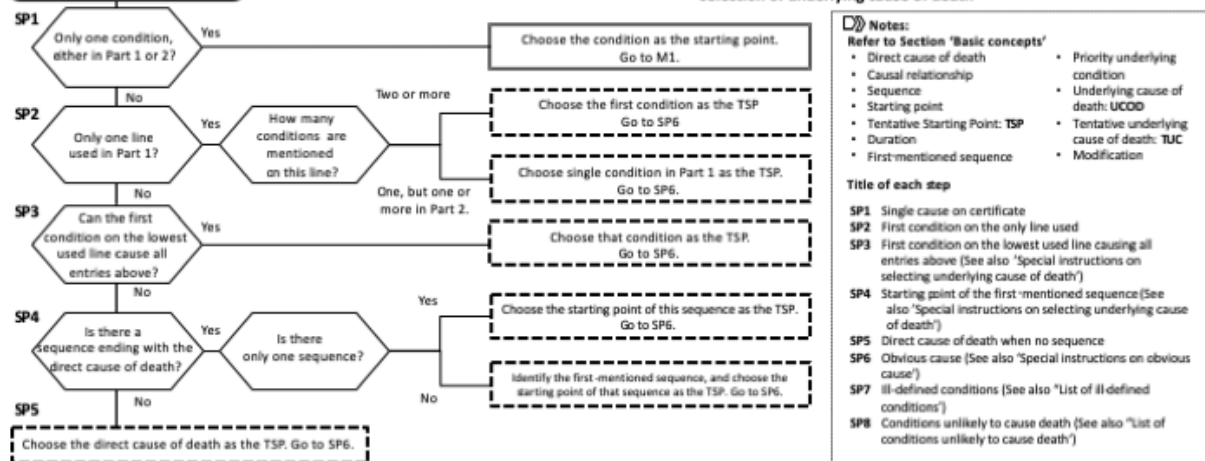

- Notes:**
- Refer to Section 'Basic concepts'
  - Direct cause of death
  - Causal relationship
  - Sequence
  - Starting point
  - Tentative Starting Point: TSP
  - Duration
  - First-mentioned sequence
  - Priority underlying condition
  - Underlying cause of death: UCOD
  - Tentative underlying cause of death: TUC
  - Modification
- Title of each step**
- SP1 Single cause on certificate
  - SP2 First condition on the only line used
  - SP3 First condition on the lowest used line causing all entries above (See also 'Special instructions on selecting underlying cause of death')
  - SP4 Starting point of the first-mentioned sequence (See also 'Special instructions on selecting underlying cause of death')
  - SP5 Direct cause of death when no sequence
  - SP6 Obvious cause (See also 'Special instructions on obvious cause')
  - SP7 Ill-defined conditions (See also 'List of ill-defined conditions')
  - SP8 Conditions unlikely to cause death (See also 'List of conditions unlikely to cause death')

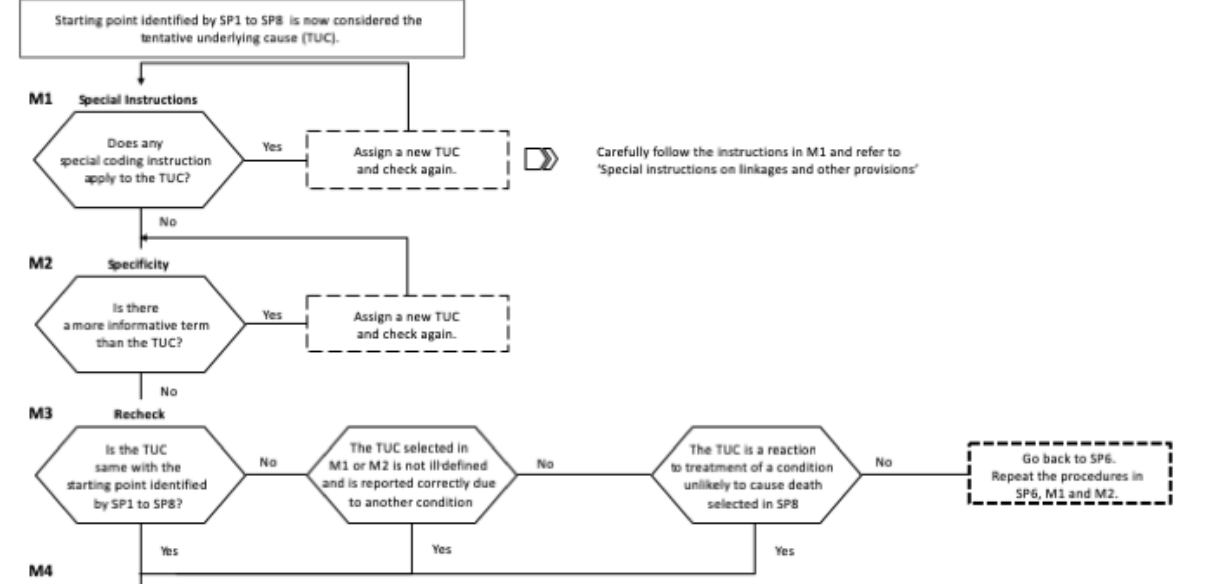
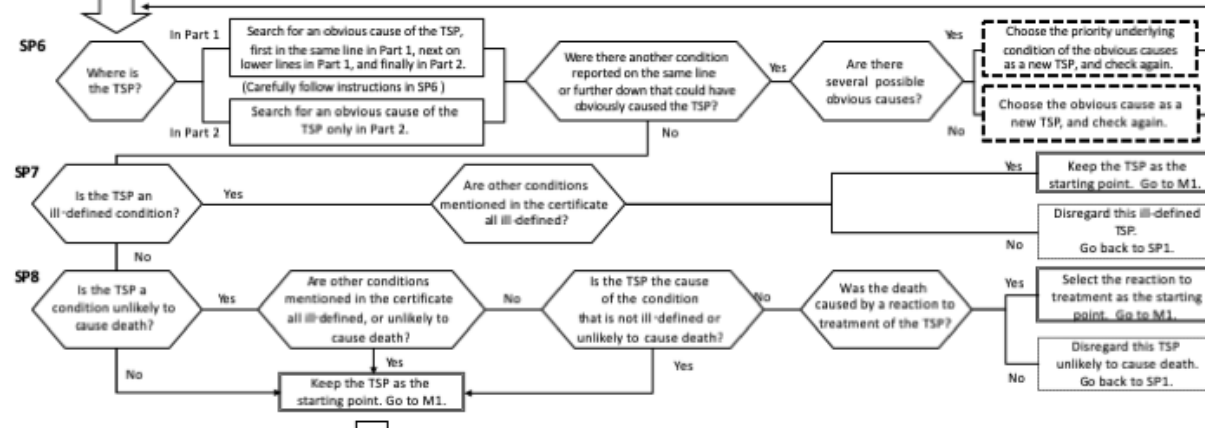

TUC is...	Special instructions	Refer to Section...
Surgery or medical procedure		'Surgery and other medical procedures'
Chapter 22 Injury or poisoning	Code the external cause as the UCOD and add the main injury	
Chapter 23 External cause	Add the main injury.	'Main injury in death from external causes'
Poisoning and more than toxic substance is reported	Identify the most important drug involved.	'Poisoning by drugs etc.'
Decedent is a woman and pregnancy, childbirth or puerperium is reported.	Determine whether to assign Chapter 18 as the UCOD	'Maternal mortality'

Find the starting point (Steps SP1 to SP8)

Check for modifications of the starting point (Steps M1 to M4)

## Workflow

### 3.14.4 Workflow diagram for mortality coding

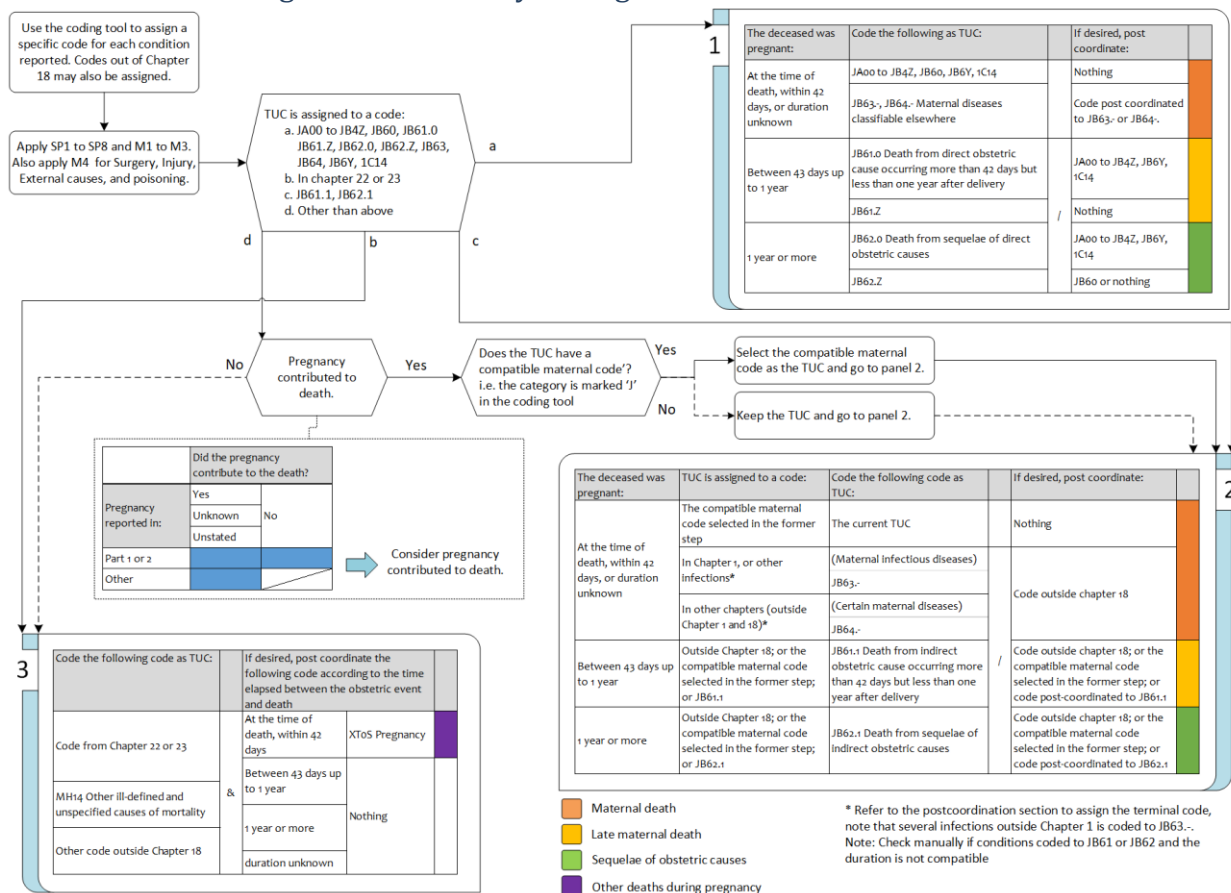

## Workflow

### 3.14.5 Priority ranking of Nature-of-Injury codes

The priority ranking of nature of injury codes is produced to standardise and facilitate coding of the main injury. The list was created with substantial input from the International Collaborative Effort (ICE) on Injury Statistics. The initial list was introduced in 2011 after testing in several countries, and updates made to correct errors in the initial list.

(1 = Highest priority rank)



<b>Code</b>	<b>Title</b>	<b>Rank</b>
<a href="#">NA00</a>	[Superficial injury of head]	6
<a href="#">NA01</a>	[Open wound of head]	6
<a href="#">NA02</a>	[Fracture of skull or facial bones]	
<a href="#">NA02.0</a>	[Fracture of vault of skull]	3
<a href="#">NA02.1</a>	[Fracture of base of skull]	4
<a href="#">NA02.2</a>	[Orbital fracture]	6
<a href="#">NA02.3</a>	[Fracture of nasal bones]	6
<a href="#">NA02.4</a>	[Fracture of maxilla]	6
<a href="#">NA02.5</a>	[Fracture of zygoma]	6
<a href="#">NA0D.02</a>	[Enamel-dentin fracture]	6
<a href="#">NA02.7</a>	[Fracture of mandible]	6
<a href="#">NA02.8</a>	[Multiple fractures involving skull or facial bones]	3
<a href="#">NA02.Y</a>	[Fracture of other specified skull or facial bones]	4
<a href="#">NA02.Z</a>	[Fracture of skull or facial bones, part unspecified]	3
<a href="#">NA03</a>	[Dislocation or strain or sprain of joints or ligaments of head]	
<a href="#">NA03.0</a>	[Dislocation of jaw]	5
<a href="#">NA03.1</a>	[Dislocation of septal cartilage of nose]	6
<a href="#">NA0D.12</a>	[Extrusive luxation of tooth]	6
<a href="#">NA03.3</a>	[Strain or sprain of jaw]	6
<a href="#">NA03.Y</a>	[Dislocation or sprain of other specified joints or ligaments of head]	6
<a href="#">NA03.Z</a>	[Dislocation or strain or sprain of joints or ligaments of head, unspecified]	6
<a href="#">NA04</a>	[Injury of cranial nerves]	6
<a href="#">NA05</a>	[Injury of blood vessels of head]	5
<a href="#">NA06</a>	[Injury of eye or orbit]	
<a href="#">NA06.0</a>	[Eyelid trauma]	6
<a href="#">NA06.1</a>	[Penetrating wound of orbit with or without foreign body]	6
<a href="#">NA06.2</a>	[Retained foreign body following penetrating wound of orbit]	6
<a href="#">NA06.3</a>	[Traumatic orbital haemorrhage]	6
<a href="#">NA06.4</a>	[Injury of conjunctiva or corneal abrasion without mention of foreign body]	6
<a href="#">NA06.5</a>	[Trauma to the iris sphincter]	6
<a href="#">NA06.6</a>	[Traumatic injuries of the retina]	6
<a href="#">NA06.7</a>	[Traumatic retinal haemorrhage]	6
<a href="#">NA06.80</a>	[Retained intraocular magnetic foreign body, unilateral]	6
<a href="#">NA06.81</a>	[Retained intraocular nonmagnetic foreign body, unilateral]	6

<b>Code</b>	<b>Title</b>	<b>Rank</b>
<a href="#">NA06.82</a>	[Closed eyeball trauma, unilateral]	6
<a href="#">NA06.83</a>	[Closed eyeball trauma, bilateral]	6
<a href="#">NA06.84</a>	[Penetrating wound of eyeball without foreign body, unilateral]	6
<a href="#">NA06.85</a>	[Avulsion of eye, unilateral]	5
<a href="#">NA06.86</a>	[Avulsion of eye, bilateral]	5
<a href="#">NA06.87</a>	[Ocular laceration or rupture with prolapse or loss of intraocular tissue, unilateral]	6
<a href="#">NA06.88</a>	[Ocular laceration or rupture with prolapse or loss of intraocular tissue, bilateral]	6
<a href="#">NA06.89</a>	[Penetrating injury of eyeball, bilateral]	6
<a href="#">NA06.8A</a>	[Perforating injury of eyeball, bilateral]	6
<a href="#">NA06.8B</a>	[Retained intraocular magnetic foreign body, bilateral]	6
<a href="#">NA06.8C</a>	[Retained intraocular nonmagnetic foreign body, bilateral]	6
<a href="#">NA06.8D</a>	[Ocular laceration without prolapse or loss of intraocular tissue, unilateral]	6
<a href="#">NA06.8E</a>	[Ocular laceration without prolapse or loss of intraocular tissue, bilateral]	6
<a href="#">NA06.8Y</a>	[Other specified traumatic injury to eyeball]	6
<a href="#">NA06.8Z</a>	[Traumatic injury to eyeball, unspecified]	6
<a href="#">NA06.9</a>	[Contusion of eyeball or orbital tissues]	6
<a href="#">NA06.A</a>	[Injury of lens]	6
<a href="#">NA06.Y</a>	[Other specified injury of eye or orbit]	6
<a href="#">NA06.Z</a>	[Injury of eye or orbit, unspecified]	6
<a href="#">NA07</a>	[Intracranial injury]	
<a href="#">NA07.0</a>	[Concussion]	6
<a href="#">NA07.1</a>	[Traumatic intracerebral haemorrhage]	2
<a href="#">NA07.2</a>	[Traumatic cerebral oedema]	1
<a href="#">NA07.3</a>	[Diffuse brain injury]	1
<a href="#">NA07.4</a>	[Focal brain injury]	2
<a href="#">NA07.5</a>	[Traumatic epidural haemorrhage]	2
<a href="#">NA07.6</a>	[Traumatic subdural haemorrhage]	2
<a href="#">NA07.7</a>	[Traumatic subarachnoid haemorrhage]	2
<a href="#">NA07.8</a>	[Traumatic haemorrhage in brain tissue]	2
<a href="#">NA07.Y</a>	[Other specified intracranial injury]	2
<a href="#">NA07.Z</a>	[Intracranial injury, unspecified]	2
<a href="#">NA08</a>	[Crushing injury of head]	
<a href="#">NA08.0</a>	[Crushing injury of brain]	1
<a href="#">NA08.1</a>	[Crushing injury of face]	5

<b>Code</b>	<b>Title</b>	<b>Rank</b>
<a href="#">NA08.2</a>	[Crushing injury of skull]	1
<a href="#">NA08.3</a>	[Crushed scalp]	1
<a href="#">NA08.Y</a>	[Other specified crushing injury of head]	1
<a href="#">NA08.Z</a>	[Crushing injury of head, unspecified]	1
<a href="#">NA09</a>	[Traumatic amputation of part of head]	
<a href="#">NA09.0</a>	[Avulsion of scalp]	6
<a href="#">NA09.1</a>	[Traumatic amputation of ear]	6
<a href="#">NA09.2</a>	[Traumatic amputation of nose]	4
<a href="#">NA09.3</a>	[Traumatic amputation of lip]	4
<a href="#">NA09.Y</a>	[Other specified traumatic amputation of part of head]	4
<a href="#">NA09.Z</a>	[Traumatic amputation of part of head, unspecified]	4
<a href="#">NA0A</a>	[Certain specified injuries of head]	
<a href="#">NA0A.0</a>	[Complex wounds to the head]	2
<a href="#">NA0A.1</a>	[Injury of muscle, fascia or tendon of head]	6
<a href="#">NA0A.2</a>	[Traumatic rupture of ear drum]	6
<a href="#">NA0A.3</a>	[Multiple injuries of head]	4
<a href="#">NA0A.Y</a>	[Other specified injuries of head]	6
<a href="#">NA0B</a>	[Injury of the auricle]	3
<a href="#">NA0C</a>	[Injury of middle or inner ear]	3
<a href="#">NA0D.0</a>	[Injury of hard dental tissues and pulp]	6
<a href="#">NA0Z</a>	[Injuries to the head, unspecified]	3
<a href="#">NA20</a>	[Superficial injury of neck]	6
<a href="#">NA21</a>	[Open wound of neck]	
<a href="#">NA21.0</a>	[Laceration without foreign body of neck]	5
<a href="#">NA21.1</a>	[Laceration with foreign body of neck]	5
<a href="#">NA21.2</a>	[Puncture wound without foreign body of neck]	5
<a href="#">NA21.3</a>	[Puncture wound with foreign body of neck]	5
<a href="#">NA21.4</a>	[Open bite of neck]	5
<a href="#">NA21.5</a>	[Multiple open wounds of neck]	5
<a href="#">NA21.Y</a>	[Other specified open wound of neck]	6
<a href="#">NA21.Z</a>	[Open wound of neck, unspecified]	6
<a href="#">NA22</a>	[Fracture of neck]	3
<a href="#">NA23</a>	[Dislocation or strain or sprain of joints or ligaments at neck level]	
<a href="#">NA23.0</a>	[Traumatic rupture of cervical intervertebral disc]	6
<a href="#">NA23.1</a>	[Dislocation of cervical vertebra]	3
<a href="#">NA23.2</a>	[Dislocation of other or unspecified parts of neck]	3

<b>Code</b>	<b>Title</b>	<b>Rank</b>
<a href="#">NA23.3</a>	[Multiple dislocations of neck]	3
<a href="#">NA23.4</a>	[Strain or sprain of cervical spine]	5
<a href="#">NA23.5</a>	[Strain or sprain of thyroid region]	6
<a href="#">NA23.Y</a>	[Other specified dislocation or strain or sprain of joints or ligaments at neck level]	3
<a href="#">NA23.Z</a>	[Dislocation or strain or sprain of joints or ligaments at neck level, unspecified]	3
<a href="#">NA30</a>	[Concussion or oedema of cervical spinal cord]	5
<a href="#">NA31</a>	[Certain specified injuries of cervical spinal cord]	3
<a href="#">NA3Z</a>	[Injury of cervical spinal cord, unspecified]	3
<a href="#">NA40</a>	[Injury of nerve root of cervical spine]	6
<a href="#">NA41</a>	[Injury of brachial plexus]	6
<a href="#">NA42</a>	[Injury of peripheral nerves of neck]	6
<a href="#">NA43</a>	[Injury of cervical sympathetic nerves]	6
<a href="#">NA44</a>	[Injury of phrenic nerve]	5
<a href="#">NA4Y</a>	[Injury of other specified nerves at neck level]	5
<a href="#">NA4Z</a>	[Injury of nerves at neck level, unspecified]	5
<a href="#">NA60</a>	[Injury of blood vessels at neck level]	
<a href="#">NA60.0</a>	[Injury of carotid artery]	1
<a href="#">NA60.1</a>	[Injury of vertebral artery]	2
<a href="#">NA60.2</a>	[Injury of external jugular vein]	3
<a href="#">NA60.3</a>	[Injury of internal jugular vein]	3
<a href="#">NA60.4</a>	[Injury of multiple blood vessels at neck level]	1
<a href="#">NA60.Y</a>	[Injury of other specified blood vessels at neck level]	1
<a href="#">NA60.Z</a>	[Injury of blood vessels at neck level, unspecified]	1
<a href="#">NA61</a>	[Injury of muscle, fascia or tendon at neck level]	6
<a href="#">NA62</a>	[Crushing injury of neck]	3
<a href="#">NA63</a>	[Traumatic amputation at neck level]	1
<a href="#">NA64</a>	[Multiple injuries of neck]	3
<a href="#">NA6Y</a>	[Other specified injuries to the neck]	4
<a href="#">NA6Z</a>	[Injuries to the neck, unspecified]	5
<a href="#">NA80</a>	[Superficial injury of thorax]	6
<a href="#">NA81</a>	[Open wound of thorax]	5
<a href="#">NA82</a>	[Fracture of rib, sternum or thoracic spine]	
<a href="#">NA82.0</a>	[Fracture of thoracic vertebra]	5
<a href="#">NA82.1</a>	[Multiple fractures of thoracic spine]	5
<a href="#">NA82.2</a>	[Fracture of sternum]	6

<b>Code</b>	<b>Title</b>	<b>Rank</b>
<a href="#">NA82.3</a>	[Fracture of rib]	6
<a href="#">NA82.4</a>	[Multiple fractures of ribs]	5
<a href="#">NA82.5</a>	[Flail chest]	2
<a href="#">NA82.Y</a>	[Other specified fracture of rib, sternum or thoracic spine]	5
<a href="#">NA82.Z</a>	[Fracture of rib, sternum or thoracic spine, unspecified]	5
<a href="#">NA83</a>	[Dislocation or strain or sprain of joints or ligaments of thorax]	
<a href="#">NA83.0</a>	[Traumatic rupture of thoracic intervertebral disc]	6
<a href="#">NA83.1</a>	[Dislocation of thoracic vertebra]	5
<a href="#">NA83.2</a>	[Dislocation of other or unspecified parts of thorax]	5
<a href="#">NA83.3</a>	[Strain or sprain of ligaments of thoracic spine]	6
<a href="#">NA83.4</a>	[Strain or sprain of ribs or sternum]	6
<a href="#">NA83.Y</a>	[Other specified dislocation or strain or sprain of joints or ligaments of thorax]	6
<a href="#">NA83.Z</a>	[Dislocation or strain or sprain of joints or ligaments of thorax, unspecified]	6
<a href="#">NA90</a>	[Concussion or oedema of thoracic spinal cord]	4
<a href="#">NA91</a>	[Certain specified injuries of thoracic spinal cord]	4
<a href="#">NA9Z</a>	[Injury of thoracic spinal cord, unspecified]	5
<a href="#">NB00</a>	[Injury of nerve root of thoracic spine]	5
<a href="#">NB01</a>	[Injury of peripheral nerves of thorax]	5
<a href="#">NB02</a>	[Injury of thoracic sympathetic nerves]	5
<a href="#">NB0Y</a>	[Injury of other specified nerves at thorax level]	5
<a href="#">NB2Y</a>	[Other specified injury of nerves or spinal cord at thorax level]	5
<a href="#">NB2Z</a>	[Injury of nerves or spinal cord at thorax level, unspecified]	5
<a href="#">NB30</a>	[Injury of blood vessels of thorax]	
<a href="#">NB30.0</a>	[Injury of thoracic aorta]	1
<a href="#">NB30.1</a>	[Injury of innominate or subclavian artery]	5
<a href="#">NB30.2</a>	[Injury of superior vena cava]	1
<a href="#">NB30.3</a>	[Injury of innominate or subclavian vein]	3
<a href="#">NB30.4</a>	[Injury of pulmonary blood vessels]	1
<a href="#">NB30.5</a>	[Injury of intercostal blood vessels]	4
<a href="#">NB30.6</a>	[Injury of multiple blood vessels of thorax]	3
<a href="#">NB30.Y</a>	[Injury of other specified blood vessels of thorax]	4
<a href="#">NB30.Z</a>	[Injury of unspecified blood vessels of thorax]	4
<a href="#">NB31</a>	[Injury of heart]	2
<a href="#">NB32</a>	[Injury of other or unspecified intrathoracic organs]	
<a href="#">NB32.0</a>	[Traumatic pneumothorax]	3

<b>Code</b>	<b>Title</b>	<b>Rank</b>
<a href="#">NB32.1</a>	[Traumatic haemothorax]	3
<a href="#">NB32.2</a>	[Traumatic haemopneumothorax]	3
<a href="#">NB32.3</a>	[Certain injuries of lung]	2
<a href="#">NB32.4</a>	[Injury of bronchus]	2
<a href="#">NB32.5</a>	[Injury of thoracic trachea]	2
<a href="#">NB32.6</a>	[Injury of pleura]	4
<a href="#">NB32.7</a>	[Multiple injuries of intrathoracic organs]	1
<a href="#">NB32.Y</a>	[Other specified injury of other or unspecified intrathoracic organs]	2
<a href="#">NB32.Z</a>	[Unspecified injury of unspecified intrathoracic organs]	2
<a href="#">NB33</a>	[Crushing injury of thorax or traumatic amputation of part of thorax]	3
<a href="#">NB34</a>	[Injury of muscle, fascia or tendon at thorax level]	6
<a href="#">NB35</a>	[Multiple injuries of thorax]	3
<a href="#">NB3Y</a>	[Other specified injuries to the thorax]	6
<a href="#">NB3Z</a>	[Injuries to the thorax, unspecified]	3
<a href="#">NB50</a>	[Superficial injury of abdomen, lower back or pelvis]	6
<a href="#">NB51</a>	[Open wound of abdomen, lower back or pelvis]	6
<a href="#">NB52</a>	[Fracture of lumbar spine or pelvis]	
<a href="#">NB52.0</a>	[Fracture of lumbar vertebra]	6
<a href="#">NB52.10</a>	[Fracture of sacrum without disruption of pelvic ring]	6
<a href="#">NB52.11</a>	[Fracture of coccyx]	6
<a href="#">NB52.12</a>	[Fracture of ilium without disruption of pelvic ring]	6
<a href="#">NB52.13</a>	[Fracture of acetabulum without disruption of pelvic ring]	5
<a href="#">NB52.14</a>	[Fracture of pubis without disruption of pelvic ring]	6
<a href="#">NB52.15</a>	[Fracture of ischium without disruption of pelvic ring]	5
<a href="#">NB52.1Y</a>	[Fracture of other specified pelvic bone without disruption of posterior arch of pelvic ring]	5
<a href="#">NB52.1Z</a>	[Fracture of unspecified pelvic bone without disruption of posterior arch of pelvic ring]	5
<a href="#">NB52.2</a>	[Fracture of the pelvic ring with incomplete disruption of posterior arch]	5
<a href="#">NB52.3</a>	[Fracture of pelvic ring with complete disruption of posterior arch]	5
<a href="#">NB52.4</a>	[Multiple fractures of lumbar spine or pelvis]	5
<a href="#">NB52.Y</a>	[Other specified fracture of lumbar spine or pelvis]	5
<a href="#">NB52.Z</a>	[Fracture of lumbar spine or pelvis, unspecified]	5

<b>Code</b>	<b>Title</b>	<b>Rank</b>
<a href="#">NB53</a>	[Dislocation or strain or sprain of joints or ligaments of lumbar spine or pelvis]	
<a href="#">NB53.0</a>	[Traumatic rupture of lumbar intervertebral disc]	6
<a href="#">NB53.1</a>	[Dislocation of lumbar vertebra]	6
<a href="#">NB53.2</a>	[Dislocation of sacroiliac or sacrococcygeal joint without disruption of pelvic ring]	6
<a href="#">NB53.3</a>	[Dislocation of other or unspecified parts of lumbar spine or pelvis without disruption of pelvic ring]	5
<a href="#">NB53.4</a>	[Traumatic rupture of symphysis pubis without disruption of pelvic ring]	6
<a href="#">NB53.5</a>	[Strain or sprain of lumbar spine]	6
<a href="#">NB53.6</a>	[Strain or sprain of sacroiliac joint]	6
<a href="#">NB52.Y</a>	[Other specified fracture of lumbar spine or pelvis]	6
<a href="#">NB52.Z</a>	[Fracture of lumbar spine or pelvis, unspecified]	5
<a href="#">NB60</a>	[Concussion or oedema of lumbar spinal cord]	6
<a href="#">NB61</a>	[Concussion or oedema of sacral spinal cord]	6
<a href="#">NB62</a>	[Certain specified injuries of lumbar spinal cord]	6
<a href="#">NB63</a>	[Certain specified injuries of sacral spinal cord]	6
<a href="#">NB6Z</a>	[Injury of spinal cord at abdomen, lower back or pelvis level, unspecified]	6
<a href="#">NB70</a>	[Injury of nerve root of lumbar spine]	6
<a href="#">NB71</a>	[Injury of nerve root of sacral spine]	6
<a href="#">NB72</a>	[Injury of cauda equina]	6
<a href="#">NB73</a>	[Injury of lumbosacral plexus]	6
<a href="#">NB74</a>	[Injury of lumbar, sacral or pelvic sympathetic nerves]	6
<a href="#">NB75</a>	[Injury of peripheral nerve of abdomen, lower back or pelvis]	6
<a href="#">NB7Y</a>	[Other specified injury of nerves at abdomen, lower back or pelvis level]	5
<a href="#">NB7Z</a>	[Injury of nerves at abdomen, lower back or pelvis level, unspecified]	5
<a href="#">NB90</a>	[Injury of blood vessels at abdomen, lower back or pelvis level]	
<a href="#">NB90.0</a>	[Injury of abdominal aorta]	1
<a href="#">NB90.1</a>	[Injury of inferior vena cava]	1
<a href="#">NB90.2</a>	[Injury of coeliac artery]	3
<a href="#">NB90.3</a>	[Injury of mesenteric artery]	
<a href="#">NB90.4</a>	[Injury of portal or splenic vein]	2
<a href="#">NB90.5</a>	[Injury of renal blood vessels]	5

<b>Code</b>	<b>Title</b>	<b>Rank</b>
<a href="#">NB90.6</a>	[Injury of iliac blood vessels]	3
<a href="#">NB90.7</a>	[Injury of multiple blood vessels at abdomen, lower back or pelvis level]	2
<a href="#">NB90.Y</a>	[Injury of other specified blood vessels at abdomen, lower back or pelvis level]	5
<a href="#">NB90.Z</a>	[Injury of unspecified blood vessel at abdomen, lower back or pelvis level]	5
<a href="#">NB91</a>	[Injury of intra-abdominal organs]	3
<a href="#">NB92</a>	[Injury of urinary or pelvic organs]	5
<a href="#">NB93</a>	[Crushing injury or traumatic amputation of part of abdomen, lower back or pelvis]	
<a href="#">NB93.0</a>	[Crushing injury of external genital organs]	6
<a href="#">NB93.1</a>	[Crushing injury of other or unspecified parts of abdomen, lower back or pelvis]	5
<a href="#">NB93.2</a>	[Traumatic amputation of external genital organs]	4
<a href="#">NB93.3</a>	[Traumatic amputation of other or unspecified parts of abdomen, lower back or pelvis]	3
<a href="#">NB94</a>	[Injury of muscle, fascia or tendon of abdomen, lower back or pelvis]	6
<a href="#">NB95</a>	[Injury of intra-abdominal organ with pelvic organ]	3
<a href="#">NB96</a>	[Other multiple injuries of abdomen, lower back or pelvis]	4
<a href="#">NB97</a>	[Certain specified injuries of abdomen, lower back or pelvis]	6
<a href="#">NB98</a>	[Injury to female genital organ without specification of injury type]	5
<a href="#">NB99</a>	[Injury to male genital organ without specification of injury type]	5
<a href="#">NB9Y</a>	[Other specified injuries to the abdomen, lower back, lumbar spine or pelvis]	4
<a href="#">NB9Z</a>	[Injuries to the abdomen, lower back, lumbar spine or pelvis, unspecified]	4
<a href="#">NC10</a>	[Superficial injury of shoulder or upper arm]	6
<a href="#">NC11</a>	[Open wound of shoulder or upper arm]	
<a href="#">NC11.0</a>	[Laceration without foreign body of shoulder or upper arm]	6
<a href="#">NC11.1</a>	[Laceration with foreign body of shoulder or upper arm]	6
<a href="#">NC11.2</a>	[Puncture wound without foreign body of shoulder or upper arm]	6
<a href="#">NC11.3</a>	[Puncture wound with foreign body of shoulder or upper arm]	6
<a href="#">NC11.4</a>	[Open bite of shoulder or upper arm]	6
<a href="#">NC11.5</a>	[Multiple open wounds of shoulder or upper arm]	6
<a href="#">NC11.Y</a>	[Other specified open wound of shoulder or upper arm]	5



<b>Code</b>	<b>Title</b>	<b>Rank</b>
<a href="#">NC11.Z</a>	[Open wound of shoulder or upper arm, unspecified]	5
<a href="#">NC12</a>	[Fracture of shoulder or upper arm]	
<a href="#">NC12.0</a>	[Fracture of clavicle]	6
<a href="#">NC12.1</a>	[Fracture of scapula]	5
<a href="#">NC12.2</a>	[Fracture of upper end of humerus]	5
<a href="#">NC12.3</a>	[Fracture of shaft of humerus]	5
<a href="#">NC12.4</a>	[Fracture of lower end of humerus]	6
<a href="#">NC12.5</a>	[Multiple fractures of clavicle, scapula or humerus]	5
<a href="#">NC12.Y</a>	[Other specified fracture of shoulder or upper arm]	5
<a href="#">NC12.Z</a>	[Fracture of shoulder or upper arm, unspecified]	5
<a href="#">NC13</a>	[Dislocation or strain or sprain of joints or ligaments of shoulder girdle]	6
<a href="#">NC14</a>	[Injury of nerves at shoulder or upper arm level]	6
<a href="#">NC15</a>	[Injury of blood vessels at shoulder or upper arm level]	
<a href="#">NC15.0</a>	[Injury of axillary artery]	3
<a href="#">NC15.1</a>	[Injury of brachial artery]	3
<a href="#">NC15.2</a>	[Injury of axillary or brachial vein]	5
<a href="#">NC15.3</a>	[Injury of superficial vein at shoulder or upper arm level]	5
<a href="#">NC15.4</a>	[Injury of multiple blood vessels at shoulder or upper arm level]	5
<a href="#">NC15.Y</a>	[Injury of other specified blood vessels at shoulder or upper arm level]	5
<a href="#">NC15.Z</a>	[Injury of unspecified blood vessel at shoulder or upper arm level]	5
<a href="#">NC16</a>	[Injury of muscle, fascia, tendon or bursa at shoulder or upper arm level]	6
<a href="#">NC17</a>	[Crushing injury of shoulder or upper arm]	5
<a href="#">NC18</a>	[Traumatic amputation of shoulder or upper arm]	3
<a href="#">NC19</a>	[Multiple injuries of shoulder or upper arm]	5
<a href="#">NC1Y</a>	[Other specified injuries to the shoulder or upper arm]	6
<a href="#">NC1Z</a>	[Injuries to the shoulder or upper arm, unspecified]	6
<a href="#">NC30</a>	[Superficial injury of forearm]	6
<a href="#">NC31</a>	[Open wound of forearm]	6
<a href="#">NC32</a>	[Fracture of forearm]	5
<a href="#">NC33</a>	[Dislocation or strain or sprain of joints or ligaments of elbow]	6
<a href="#">NC34</a>	[Injury of nerves at forearm level]	6
<a href="#">NC35</a>	[Injury of blood vessels at forearm level]	
<a href="#">NC35.0</a>	[Injury of ulnar artery at forearm level]	6
<a href="#">NC35.1</a>	[Injury of radial artery at forearm level]	5

<b>Code</b>	<b>Title</b>	<b>Rank</b>
<a href="#">NC35.2</a>	[Injury of vein at forearm level]	5
<a href="#">NC35.3</a>	[Injury of multiple blood vessels at forearm level]	5
<a href="#">NC35.Y</a>	[Injury of other specified blood vessels at forearm level]	6
<a href="#">NC35.Z</a>	[Injury of unspecified blood vessel at forearm level]	6
<a href="#">NC36</a>	[Injury of muscle, fascia, tendon or bursa at forearm level]	6
<a href="#">NC37</a>	[Crushing injury of forearm]	6
<a href="#">NC38</a>	[Traumatic amputation of forearm]	4
<a href="#">NC39</a>	[Multiple injuries of forearm]	4
<a href="#">NC3Y</a>	[Other specified injuries to the elbow or forearm]	6
<a href="#">NC3Z</a>	[Injuries to the elbow or forearm, unspecified]	5
<a href="#">NC50</a>	[Injury to fingernail]	5
<a href="#">NC51</a>	[Superficial injury of wrist or hand]	6
<a href="#">NC52</a>	[Open wound of wrist or hand]	6
<a href="#">NC53</a>	[Fracture at wrist or hand level]	
<a href="#">NC53.0</a>	[Fracture of scaphoid bone of hand]	6
<a href="#">NC53.1</a>	[Fracture of other carpal bone]	6
<a href="#">NC53.2</a>	[Fracture of first metacarpal bone]	6
<a href="#">NC53.3</a>	[Fracture of other metacarpal bone]	6
<a href="#">NC53.4</a>	[Multiple fractures of metacarpal bones]	6
<a href="#">NC53.5</a>	[Fracture of thumb bone]	6
<a href="#">NC53.6</a>	[Fracture of other finger bone]	6
<a href="#">NC53.7</a>	[Multiple fractures of fingers]	6
<a href="#">NC53.Y</a>	[Fracture at other specified part of wrist or hand level]	5
<a href="#">NC53.Z</a>	[Fracture at wrist or hand level, unspecified]	5
<a href="#">NC54</a>	[Dislocation or strain or sprain of joints or ligaments at wrist or hand level]	6
<a href="#">NC55</a>	[Injury of nerves at wrist or hand level]	6
<a href="#">NC56</a>	[Injury of blood vessels at wrist or hand level]	
<a href="#">NC56.0</a>	[Injury of ulnar artery at wrist or hand level]	6
<a href="#">NC56.1</a>	[Injury of radial artery at wrist or hand level]	5
<a href="#">NC56.2</a>	[Injury of superficial palmar arch]	6
<a href="#">NC56.3</a>	[Injury of deep palmar arch]	6
<a href="#">NC56.4</a>	[Injury of blood vessel of thumb]	6
<a href="#">NC56.5</a>	[Injury of blood vessel of other finger]	6
<a href="#">NC56.6</a>	[Injury of multiple blood vessels at wrist or hand level]	6
<a href="#">NC56.Y</a>	[Injury of other specified blood vessels at wrist or hand level]	5
<a href="#">NC56.Z</a>	[Injury of unspecified blood vessel at wrist or hand level]	5

<b>Code</b>	<b>Title</b>	<b>Rank</b>
<a href="#">NC57</a>	[Injury of muscle, fascia or tendon at wrist or hand level]	6
<a href="#">NC58</a>	[Crushing injury of wrist or hand]	6
<a href="#">NC59</a>	[Traumatic amputation of wrist or hand]	
<a href="#">NC59.0</a>	[Traumatic amputation of thumb]	6
<a href="#">NC59.1</a>	[Traumatic amputation of other single finger]	6
<a href="#">NC59.2</a>	[Traumatic amputation of two or more fingers alone]	6
<a href="#">NC59.3</a>	[Combined traumatic amputation of finger with other parts of wrist or hand]	6
<a href="#">NC59.4</a>	[Traumatic amputation of hand at metacarpal level]	6
<a href="#">NC59.Z</a>	[Traumatic amputation of wrist or hand, unspecified]	4
<a href="#">NC5A</a>	[Multiple injuries of wrist or hand]	5
<a href="#">NC5Y</a>	[Other specified injuries to the wrist or hand]	5
<a href="#">NC5Z</a>	[Injuries to the wrist or hand, unspecified]	5
<a href="#">NC70</a>	[Superficial injury of hip or thigh]	6
<a href="#">NC71</a>	[Open wound of hip or thigh]	6
<a href="#">NC72</a>	[Fracture of femur]	
<a href="#">NC72.0</a>	[Fracture of head of femur]	3
<a href="#">NC72.1</a>	[Fracture of upper epiphysis of femur]	3
<a href="#">NC72.2</a>	[Fracture of neck of femur]	3
<a href="#">NC72.3</a>	[Fracture of trochanteric section of femur]	3
<a href="#">NC72.4</a>	[Subtrochanteric fracture of femur]	3
<a href="#">NC72.5</a>	[Fracture of shaft of femur]	4
<a href="#">NC72.6</a>	[Fracture of lower end of femur]	4
<a href="#">NC72.7</a>	[Multiple fractures of femur]	4
<a href="#">NC72.8</a>	[Fractures of other parts of femur]	4
<a href="#">NC72.Y</a>	[Other specified fracture of femur]	4
<a href="#">NC72.Z</a>	[Fracture of femur, unspecified]	4
<a href="#">NC73</a>	[Dislocation or strain or sprain of joint or ligaments of hip]	6
<a href="#">NC74</a>	[Injury of nerves at hip or thigh level]	
<a href="#">NC74.0</a>	[Injury of sciatic nerve at hip or thigh level]	6
<a href="#">NC74.1</a>	[Injury of femoral nerve at hip or thigh level]	6
<a href="#">NC74.2</a>	[Injury of cutaneous sensory nerve at hip or thigh level]	5
<a href="#">NC74.3</a>	[Injury of multiple nerves at hip or thigh level]	5
<a href="#">NC74.Y</a>	[Injury of other specified nerves at hip or thigh level]	6
<a href="#">NC74.Z</a>	[Injury of unspecified nerve at hip or thigh level]	6
<a href="#">NC75</a>	[Injury of blood vessels at hip or thigh level]	
<a href="#">NC75.0</a>	[Injury of femoral artery]	4

<b>Code</b>	<b>Title</b>	<b>Rank</b>
<a href="#">NC75.1</a>	[Injury of femoral vein at hip or thigh level]	5
<a href="#">NC75.2</a>	[Injury of greater saphenous vein at hip or thigh level]	6
<a href="#">NC75.3</a>	[Injury of multiple blood vessels at hip or thigh level]	5
<a href="#">NC75.Y</a>	[Injury of other specified blood vessels at hip or thigh level]	6
<a href="#">NC75.Z</a>	[Injury of unspecified blood vessel at hip or thigh level]	6
<a href="#">NC76</a>	[Injury of muscle, fascia, tendon or bursa at hip or thigh level]	6
<a href="#">NC77</a>	[Crushing injury of hip or thigh]	5
<a href="#">NC78</a>	[Traumatic amputation of hip or thigh]	3
<a href="#">NC79</a>	[Multiple injuries of hip or thigh]	5
<a href="#">NC7Y</a>	[Other specified injuries to the hip or thigh]	5
<a href="#">NC7Z</a>	[Injuries to the hip or thigh, unspecified]	5
<a href="#">NC90</a>	[Superficial injury of knee or lower leg]	6
<a href="#">NC91</a>	[Open wound of knee or lower leg]	6
<a href="#">NC92</a>	[Fracture of lower leg, including ankle]	5
<a href="#">NC93</a>	[Dislocation or strain or sprain of joints or ligaments of knee]	6
<a href="#">NC94</a>	[Injury of nerves at lower leg level]	6
<a href="#">NC95</a>	[Injury of blood vessels at lower leg level]	
<a href="#">NC95.0</a>	[Injury of popliteal artery]	5
<a href="#">NC95.1</a>	[Injury of anterior tibial artery]	6
<a href="#">NC95.2</a>	[Injury of posterior tibial artery]	6
<a href="#">NC95.3</a>	[Injury of peroneal artery]	6
<a href="#">NC95.4</a>	[Injury of greater saphenous vein at lower leg level]	5
<a href="#">NC95.5</a>	[Injury of lesser saphenous vein at lower leg level]	6
<a href="#">NC95.6</a>	[Injury of popliteal vein]	6
<a href="#">NC95.7</a>	[Injury of multiple blood vessels at lower leg level]	5
<a href="#">NC95.Y</a>	[Injury of other specified blood vessels at lower leg level]	6
<a href="#">NC95.Z</a>	[Injury of unspecified blood vessel at lower leg level]	5
<a href="#">NC96</a>	[Injury of muscle, fascia, tendon or bursa at lower leg level]	
<a href="#">NC96.0</a>	[Injury of Achilles tendon]	6
<a href="#">NC96.1</a>	[Injury of other muscle, fascia or tendon of posterior muscle group at lower leg level]	6
<a href="#">NC96.2</a>	[Injury of muscle, fascia or tendon of anterior muscle group at lower leg level]	6
<a href="#">NC96.3</a>	[Injury of muscle, fascia or tendon of peroneal muscle group at lower leg level]	6
<a href="#">NC96.4</a>	[Injury of multiple muscles, fasciae or tendons at lower leg level]	6
<a href="#">NC96.5</a>	[Injury of bursa of knee]	5

<b>Code</b>	<b>Title</b>	<b>Rank</b>
<a href="#">NC96.Y</a>	[Injury of other specified muscle, fascia, tendon or bursa at lower leg level]	5
<a href="#">NC96.Z</a>	[Injury of unspecified muscle, fascia, tendon or bursa at lower leg level]	6
<a href="#">NC97</a>	[Crushing injury of lower leg]	
<a href="#">NC97.0</a>	[Crushing injury of knee]	6
<a href="#">NC97.Y</a>	[Crushing injury of other specified part of lower leg]	5
<a href="#">NC97.Z</a>	[Crushing injury of lower leg, unspecified]	5
<a href="#">NC98</a>	[Traumatic amputation of lower leg]	
<a href="#">NC98.0</a>	[Traumatic amputation of right lower leg at knee level]	3
<a href="#">NC98.1</a>	[Traumatic amputation of left lower leg at knee level]	3
<a href="#">NC98.2</a>	[Traumatic amputation at knee level, bilateral]	3
<a href="#">NC98.3</a>	[Traumatic amputation at level between right knee and ankle]	3
<a href="#">NC98.4</a>	[Traumatic amputation at level between left knee and ankle]	3
<a href="#">NC98.5</a>	[Traumatic amputation at level between knee and ankle, bilateral]	3
<a href="#">NC98.Y</a>	[Other specified traumatic amputation of lower leg]	4
<a href="#">NC98.Z</a>	[Traumatic amputation of lower leg, unspecified]	4
<a href="#">NC99</a>	[Multiple injuries of lower leg]	5
<a href="#">NC9Y</a>	[Other specified injuries to the knee or lower leg]	5
<a href="#">NC9Z</a>	[Injuries to the knee or lower leg, unspecified]	5
<a href="#">ND10</a>	[Injury to toenail]	6
<a href="#">ND11</a>	[Superficial injury of ankle or foot]	6
<a href="#">ND12</a>	[Open wound of ankle or foot]	6
<a href="#">ND13</a>	[Fracture of foot, except ankle]	6
<a href="#">ND14</a>	[Dislocation or strain or sprain of joints or ligaments at ankle or foot level]	6
<a href="#">ND15</a>	[Injury of nerves at ankle or foot level]	6
<a href="#">ND16</a>	[Injury of blood vessels at ankle or foot level]	
<a href="#">ND16.0</a>	[Injury of dorsal artery of foot]	6
<a href="#">ND16.1</a>	[Injury of plantar artery of foot]	5
<a href="#">ND16.2</a>	[Injury of dorsal vein of foot]	6
<a href="#">ND16.3</a>	[Injury of multiple blood vessels at ankle or foot level]	6
<a href="#">ND16.Y</a>	[Injury of other specified blood vessels at ankle or foot level]	6
<a href="#">ND16.Z</a>	[Injury of unspecified blood vessel at ankle or foot level]	6
<a href="#">ND17</a>	[Injury of muscle, fascia or tendon at ankle or foot level]	6
<a href="#">ND18</a>	[Crushing injury of ankle or foot]	
<a href="#">ND18.0</a>	[Crushing injury of ankle]	6

<b>Code</b>	<b>Title</b>	<b>Rank</b>
<a href="#">ND18.1</a>	[Crushing injury of toe]	5
<a href="#">ND18.2</a>	[Crushing injury of other parts of ankle or foot]	6
<a href="#">ND18.Z</a>	[Crushing injury of ankle or foot, unspecified]	6
<a href="#">ND19</a>	[Traumatic amputation of ankle or foot]	
<a href="#">ND19.0</a>	[Traumatic amputation of right foot at ankle level]	4
<a href="#">ND19.1</a>	[Traumatic amputation of left foot at ankle level]	4
<a href="#">ND19.2</a>	[Traumatic amputation of foot at ankle level, bilateral]	4
<a href="#">ND19.3</a>	[Traumatic amputation of right foot at metatarsal level]	6
<a href="#">ND19.4</a>	[Traumatic amputation of left foot at metatarsal level]	6
<a href="#">ND19.5</a>	[Traumatic amputation of foot at metatarsal level, bilateral]	6
<a href="#">ND19.6</a>	[Traumatic amputation of one toe]	6
<a href="#">ND19.7</a>	[Traumatic amputation of two or more toes]	6
<a href="#">ND19.8</a>	[Traumatic amputation of other parts of foot]	6
<a href="#">ND19.Z</a>	[Traumatic amputation of ankle or foot, unspecified]	6
<a href="#">ND1A</a>	[Multiple injuries of ankle or foot]	5
<a href="#">ND1Y</a>	[Other specified injuries to the ankle or foot]	5
<a href="#">ND1Z</a>	[Injuries to the ankle or foot, unspecified]	5
<a href="#">ND30</a>	[Superficial injuries involving multiple body regions]	6
<a href="#">ND31</a>	[Open wounds involving multiple body regions]	5
<a href="#">ND32</a>	[Fractures involving multiple body regions]	3
<a href="#">ND33</a>	[Dislocations, strains or sprains involving multiple body regions]	5
<a href="#">ND34</a>	[Crushing injuries involving multiple body regions]	5
<a href="#">ND35</a>	[Traumatic amputations involving multiple body regions]	5
<a href="#">ND36</a>	[Other injuries involving multiple body regions, not elsewhere classified]	3
<a href="#">ND37</a>	[Unspecified multiple injuries]	2
<a href="#">ND50</a>	[Fracture of spine, level unspecified]	5
<a href="#">ND51</a>	[Other injuries of spine or trunk, level unspecified]	
<a href="#">ND51.0</a>	[Dislocation or strain or sprain of unspecified joint or ligament of trunk]	6
<a href="#">ND51.1</a>	[Injury of unspecified nerve, spinal nerve root or plexus of trunk]	4
<a href="#">ND51.2</a>	[Injury of spinal cord, level unspecified]	3
<a href="#">ND51.3</a>	[Injury of unspecified muscle, fascia or tendon of trunk]	6
<a href="#">ND51.4</a>	[Crushing injury of spine or trunk, level unspecified]	5
<a href="#">ND51.Y</a>	[Other specified injuries of spine or trunk, level unspecified]	5
<a href="#">ND51.Z</a>	[Unspecified injuries of spine or trunk, level unspecified]	5

<b>Code</b>	<b>Title</b>	<b>Rank</b>
<a href="#">ND52</a>	[Fracture of arm, level unspecified]	5
<a href="#">ND53</a>	[Other injuries of arm, level unspecified]	6
<a href="#">ND54</a>	[Fracture of leg, level unspecified]	5
<a href="#">ND55</a>	[Other injuries of leg, level unspecified]	6
<a href="#">ND56</a>	[Injury of unspecified body region]	
<a href="#">ND56.0</a>	[Superficial injury of unspecified body region]	6
<a href="#">ND56.1</a>	[Open wound of unspecified body region]	5
<a href="#">ND56.2</a>	[Fracture of unspecified body region]	5
<a href="#">ND56.3</a>	[Dislocation or strain or sprain of unspecified body region]	6
<a href="#">ND56.4</a>	[Injury of nerve of unspecified body region]	6
<a href="#">ND56.5</a>	[Injury of blood vessel of unspecified body region]	5
<a href="#">ND56.6</a>	[Injury of muscles or tendons of unspecified body region]	6
<a href="#">ND56.7</a>	[Crushing injury of unspecified body region]	2
<a href="#">ND56.8</a>	[Traumatic amputation of unspecified body region]	2
<a href="#">ND56.9</a>	[Injury complicating pregnancy]	6
<a href="#">ND56.Y</a>	[Other specified injury of unspecified body region]	6
<a href="#">ND56.Z</a>	[Unspecified injury to unspecified part of trunk, limb or body region]	6
<a href="#">ND57</a>	[Secondary effect of trauma]	6
<a href="#">ND5Y</a>	[Other specified injuries to unspecified part of trunk, limb or body region]	6
<a href="#">ND5Z</a>	[Injuries to unspecified part of trunk, limb or body region, unspecified]	6
<a href="#">ND70</a>	[Foreign body on external eye]	
<a href="#">ND70.0</a>	[Foreign body in cornea]	6
<a href="#">ND70.1</a>	[Foreign body in conjunctival sac]	6
<a href="#">ND70.2</a>	[Foreign body in multiple parts of external eye]	6
<a href="#">ND70.Y</a>	[Foreign body in other specified part of external eye]	6
<a href="#">ND70.Z</a>	[Foreign body on external eye, unspecified]	5
<a href="#">ND71</a>	[Foreign body in ear]	6
<a href="#">ND72</a>	[Foreign body in respiratory tract]	5
<a href="#">ND73</a>	[Foreign body in alimentary tract]	
<a href="#">ND73.0</a>	[Foreign body in mouth]	6
<a href="#">ND73.1</a>	[Foreign body in oesophagus]	6
<a href="#">ND73.2</a>	[Foreign body in stomach]	6
<a href="#">ND73.3</a>	[Foreign body in small intestine]	5
<a href="#">ND73.4</a>	[Foreign body in colon]	5

<b>Code</b>	<b>Title</b>	<b>Rank</b>
<a href="#">ND73.5</a>	[Foreign body in anus or rectum]	6
<a href="#">ND73.Y</a>	[Foreign body in other specified part of alimentary tract]	6
<a href="#">ND73.Z</a>	[Foreign body in alimentary tract, unspecified]	6
<a href="#">ND74</a>	[Foreign body in genitourinary tract]	
<a href="#">ND74.0</a>	[Foreign body in urethra]	6
<a href="#">ND74.1</a>	[Foreign body in bladder]	6
<a href="#">ND74.2</a>	[Foreign body in vulva or vagina]	5
<a href="#">ND74.3</a>	[Foreign body in uterus, any part]	6
<a href="#">ND74.Y</a>	[Foreign body in other specified part of genitourinary tract]	6
<a href="#">ND74.Z</a>	[Foreign body in genitourinary tract, unspecified]	5
<a href="#">ND7Z</a>	[Effects of foreign body entering through natural orifice, unspecified]	6
<a href="#">ND90</a>	[Burn of head or neck except face]	
<a href="#">ND90.0</a>	[Burn of head or neck except face, epidermal burn]	6
<a href="#">ND90.1</a>	[Burn of head or neck except face, superficial partial thickness burn]	6
<a href="#">ND90.2</a>	[Burn of head or neck except face, deep partial thickness burn]	6
<a href="#">ND90.3</a>	[Burn of head or neck except face, full thickness burn]	3
<a href="#">ND90.4</a>	[Burn of head or neck except face, deep full thickness or complex burn]	3
<a href="#">ND90.Z</a>	[Burn of head or neck except face, depth of burn unspecified]	6
<a href="#">ND91</a>	[Burn of face except eye or ocular adnexa]	
<a href="#">ND91.0</a>	[Burn of face except eye or ocular adnexa, epidermal burn]	6
<a href="#">ND91.1</a>	[Burn of face except eye or ocular adnexa, superficial partial thickness burn]	6
<a href="#">ND91.2</a>	[Burn of face except eye or ocular adnexa, deep partial thickness burn]	6
<a href="#">ND91.3</a>	[Burn of face except eye or ocular adnexa, full thickness burn]	3
<a href="#">ND91.4</a>	[Burn of face except eye or ocular adnexa, deep full thickness or complex burn]	3
<a href="#">ND91.Z</a>	[Burn of face except eye, depth of burn unspecified]	6
<a href="#">ND92</a>	[Burn of trunk except perineum or genitalia]	
<a href="#">ND92.0</a>	[Burn of trunk except perineum or genitalia, epidermal burn]	6
<a href="#">ND92.1</a>	[Burn of trunk except perineum or genitalia, superficial partial thickness burn]	6
<a href="#">ND92.2</a>	[Burn of trunk except perineum or genitalia, deep partial thickness burn]	6
<a href="#">ND92.3</a>	[Burn of trunk except perineum or genitalia, full thickness burn]	3



<b>Code</b>	<b>Title</b>	<b>Rank</b>
<a href="#">ND92.4</a>	[Burn of trunk except perineum or genitalia, deep full thickness or complex burn]	3
<a href="#">ND92.Z</a>	[Burn of trunk except perineum or genitalia, depth of burn unspecified]	6
<a href="#">ND93</a>	[Burn of perineum or genitalia]	
<a href="#">ND93.0</a>	[Burn of perineum or genitalia, epidermal burn]	6
<a href="#">ND93.1</a>	[Burn of perineum or genitalia, superficial partial thickness burn]	6
<a href="#">ND93.2</a>	[Burn of perineum or genitalia, deep partial thickness burn]	6
<a href="#">ND93.3</a>	[Burn of perineum or genitalia, full thickness burn]	3
<a href="#">ND93.4</a>	[Burn of perineum or genitalia, deep full thickness or complex burn]	3
<a href="#">ND93.Z</a>	[Burn of perineum or genitalia, depth of burn unspecified]	6
<a href="#">ND94</a>	[Burn of shoulder or arm, except wrist or hand]	
<a href="#">ND94.0</a>	[Burn of shoulder or arm, except wrist or hand, epidermal burn]	6
<a href="#">ND94.1</a>	[Burn of shoulder or arm, except wrist or hand, superficial partial thickness burn]	6
<a href="#">ND94.2</a>	[Burn of shoulder or arm, except wrist or hand, deep partial thickness burn]	6
<a href="#">ND94.3</a>	[Burn of shoulder or arm, except wrist or hand, full thickness burn]	5
<a href="#">ND94.4</a>	[Burn of shoulder or arm, except wrist or hand, deep full thickness or complex burn]	5
<a href="#">ND94.Z</a>	[Burn of shoulder or arm except wrist or hand, depth of burn unspecified]	6
<a href="#">ND95</a>	[Burn of wrist or hand]	
<a href="#">ND95.0</a>	[Burn of wrist or hand, epidermal burn]	6
<a href="#">ND95.1</a>	[Burn of wrist or hand, superficial partial thickness burn]	6
<a href="#">ND95.2</a>	[Burn of wrist or hand, deep partial thickness burn]	6
<a href="#">ND95.3</a>	[Burn of wrist or hand, full thickness burn]	5
<a href="#">ND95.4</a>	[Burn of wrist or hand, deep full thickness or complex burn]	5
<a href="#">ND95.Z</a>	[Burn of wrist or hand, depth of burn unspecified]	6
<a href="#">ND96</a>	[Burn of hip or leg, except ankle or foot]	
<a href="#">ND96.0</a>	[Burn of hip or leg, except ankle or foot, epidermal burn]	6
<a href="#">ND96.1</a>	[Burn of hip or leg, except ankle or foot, superficial partial thickness burn]	6
<a href="#">ND96.2</a>	[Burn of hip or leg, except ankle or foot, deep partial thickness burn]	6
<a href="#">ND96.3</a>	[Burn of hip or leg, except ankle or foot, full thickness burn]	5

<b>Code</b>	<b>Title</b>	<b>Rank</b>
<a href="#">ND96.4</a>	[Burn of hip or leg, except ankle or foot, deep full thickness or complex burn]	5
<a href="#">ND96.Z</a>	[Burn of hip or leg except ankle or foot, depth of burn unspecified]	6
<a href="#">ND97</a>	[Burn of ankle or foot]	
<a href="#">ND97.0</a>	[Burn of ankle or foot, epidermal burn]	6
<a href="#">ND97.1</a>	[Burn of ankle or foot, superficial partial thickness burn]	6
<a href="#">ND97.2</a>	[Burn of ankle or foot, deep partial thickness burn]	6
<a href="#">ND97.3</a>	[Burn of ankle or foot, full thickness burn]	5
<a href="#">ND97.4</a>	[Burn of ankle or foot, deep full thickness or complex burn]	5
<a href="#">ND97.Z</a>	[Burn of ankle or foot, depth of burn unspecified]	6
<a href="#">ND99.1</a>	[Chemical burn due to skin contact with corrosive substance]	6
<a href="#">ND99</a>	[Acute skin injury due to skin contact with corrosive substance]	6
<a href="#">ND9Y</a>	[Burns of external body surface, other specified site]	6
<a href="#">ND9Z</a>	[Burns of external body surface, unspecified site]	6
<a href="#">NE00</a>	[Burn of eye or ocular adnexa]	6
<a href="#">NE01</a>	[Burn of respiratory tract]	3
<a href="#">NE02</a>	[Burn of other internal organs]	3
<a href="#">NE0Z</a>	[Burns of unspecified internal organ]	6
<a href="#">NE10</a>	[Burns of multiple body regions]	6
<a href="#">NE11</a>	[Burn of unspecified body region]	6
<a href="#">NE2Z</a>	[Burns, unspecified]	3
<a href="#">NE40</a>	[Superficial frostbite]	6
<a href="#">NE41</a>	[Frostbite with tissue necrosis]	6
<a href="#">NE42</a>	[Frostbite involving multiple body regions]	6
<a href="#">NE4Z</a>	[Frostbite, unspecified]	5
<a href="#">NF00</a>	[Effects of radiation, not elsewhere classified]	6
<a href="#">NF01</a>	[Effects of heat]	
<a href="#">NF01.0</a>	[Heat stroke]	3
<a href="#">NF01.1</a>	[Heat syncope]	6
<a href="#">NF01.2</a>	[Heat exhaustion due to fluid depletion]	6
<a href="#">NF01.3</a>	[Heat fatigue, transient]	6
<a href="#">NF01.Y</a>	[Other specified effects of heat]	6
<a href="#">NF01.Z</a>	[Effects of heat, unspecified]	5
<a href="#">NF02</a>	[Hypothermia]	3
<a href="#">NF03</a>	[Other effects of reduced temperature]	
<a href="#">NF03.0</a>	[Chilblains]	5

<b>Code</b>	<b>Title</b>	<b>Rank</b>
<a href="#">NF03.1</a>	[Immersion hand or foot]	6
<a href="#">NF03.Y</a>	[Other specified effects of reduced temperature]	4
<a href="#">NF03.Z</a>	[Unspecified effects of reduced temperature]	4
<a href="#">NF04</a>	[Effects of air pressure or water pressure]	
<a href="#">NF04.0</a>	[Otitic barotrauma]	5
<a href="#">NF04.1</a>	[Sinus barotrauma]	4
<a href="#">NF04.2</a>	[Caisson disease]	5
<a href="#">NF04.3</a>	[Effects of high-pressure fluids]	6
<a href="#">NF04.Y</a>	[Other specified effects of air pressure or water pressure]	6
<a href="#">NF04.Z</a>	[Effects of air pressure or water pressure, unspecified]	5
<a href="#">NF05</a>	[Asphyxiation]	1
<a href="#">NF06</a>	[Effects of strenuous physical exercise]	
<a href="#">NF06.0</a>	[Exertional heat stroke]	3
<a href="#">NF06.1</a>	[Post exercise postural hypotension]	6
<a href="#">NF06.2</a>	[Post exertional dehydration]	6
<a href="#">NF06.3</a>	[Exercise muscle cramp]	6
<a href="#">NF06.Y</a>	[Other specified effects of strenuous physical exercise]	6
<a href="#">NF06.Z</a>	[Effects of strenuous physical exercise, unspecified]	6
<a href="#">NF07</a>	[Effects of other deprivation]	
<a href="#">NF07.0</a>	[Effects of hunger]	3
<a href="#">NF07.1</a>	[Effects of thirst]	5
<a href="#">NF07.2</a>	[Exhaustion due to exposure]	6
<a href="#">NF07.Y</a>	[Other specified effects of deprivation]	6
<a href="#">NF07.Z</a>	[Effects of other deprivation, unspecified]	6
<a href="#">NF08</a>	[Effects of certain specified external causes]	
<a href="#">NF08.0</a>	[Effects of lightning]	4
<a href="#">NF08.1</a>	[Drowning or nonfatal submersion]	2
<a href="#">NF08.2</a>	[Effects of vibration]	6
<a href="#">NF08.3</a>	[Motion sickness]	6
<a href="#">NF08.4</a>	[Effects of electric current]	3
<a href="#">NF0Y</a>	[Other specified effects of external causes]	6
<a href="#">NF0Z</a>	[Unspecified effects of external causes]	6
<a href="#">NF2Y</a>	[Other specified injury, poisoning or certain other consequences of external causes]	6
<a href="#">NF2Z</a>	[Unspecified injury, poisoning or certain other consequences of external causes]	6

### 3.14.6 List of ill-defined conditions

Use this table in Step SP7. Conditions in this table are considered ill-defined and are not for use as underlying cause of death.

<b>Code or Chapter</b>	<b>Category title</b>
<a href="#">BD10-BD1Z</a>	Heart failure in <a href="#">BD10</a> - specified as acute ( <a href="#">XT5R</a> )
<a href="#">BA2Z</a>	Hypotension, unspecified
<a href="#">BE2Y</a>	Other specified diseases of the circulatory system
<a href="#">BE2Z</a>	Diseases of the circulatory system, unspecified
<a href="#">CB41.0</a>	Acute respiratory failure
<a href="#">CB41.2</a>	Respiratory failure, unspecified as acute or chronic
<a href="#">KB2D</a>	Respiratory failure of newborn
<a href="#">KB2E</a>	Respiratory arrest of newborn
Chapter 21	Symptoms, signs or clinical findings, not elsewhere classified; except conditions listed below: <a href="#">MA15</a> <i>Microbiological findings in blood, blood-forming organs, or the immune system</i> <a href="#">MG43</a> <i>Symptoms or signs concerning food or fluid intake</i> <a href="#">MG44.1</a> <i>Lack of expected normal physiological development</i> <a href="#">MH11</a> <i>Sudden infant death syndrome</i> <a href="#">MH15</a> <i>Sudden unexpected death in epilepsy</i>

### 3.14.7 List of conditions that can cause HIV disease

This list to be used to support the Special instructions on accepted and rejected sequences Steps SP3-SP4 to assess the sequence for deaths where HIV is reported on the death certificate. Note that this list is not complete and should be considered indicative. Accept HIV due to:

<b>Code</b>	<b>Category</b>
<b><i>Malignant neoplasms</i></b>	
2B50-2E2Z	Malignant neoplasms, <b>except</b> primary neoplasms of lymphoid, haematopoietic, central nervous system or related tissues
<b><i>Certain anaemias or other erythrocyte disorders</i></b>	
3A00-3A03	Nutritional or metabolic anaemias
3A10-3A4Z	Haemolytic anaemias
3A60-3A6Z	Pure red cell aplasia
<a href="#">3A50</a>	Thalassaemias
<a href="#">3A51</a>	Sickle cell disorders or other haemoglobinopathies
<a href="#">3A70</a>	Aplastic anaemia
<a href="#">3A71</a>	Anaemia due to chronic disease
<a href="#">3A72</a>	Sideroblastic anaemia
<a href="#">3A73</a>	Congenital dyserythropoietic anaemia
<a href="#">3A90</a>	Anaemia due to acute disease
<a href="#">3A9Y</a>	Other specified anaemias and erythrocyte disorders
<a href="#">3A9Z</a>	Anaemias or other erythrocyte disorders, unspecified
3B10-3B6Z	Coagulation defects, purpura or other haemorrhagic or related conditions

***Certain disorders due to substance use or addictive behaviours***

[6C43](#)

Disorders due to use of opioids

[6C44](#)

Disorders due to use of sedatives, hypnotics or anxiolytics

[6C45](#)

Disorders due to use of cocaine

[6C46](#)

Disorders due to use of stimulants including amphetamines, methamphetamine or methcathinone

[6C48](#)

Disorders due to use of caffeine

[6C49](#)

Disorders due to use of hallucinogens

[6C4C](#)

Disorders due to use of MDMA or related drugs, including MDA

[6C4D](#)

Disorders due to use of dissociative drugs including ketamine and phencyclidine [PCP]

[6C4E](#)

Disorders due to use of other specified psychoactive substances, including medications

[6C4F](#)

Disorders due to use of multiple specified psychoactive substances, including medications

[6C4G](#)

Disorders due to use of unknown or unspecified psychoactive substances

[6C4Y](#)

Other specified disorders due to substance use

[6C4Z](#)

Disorders due to substance use, unspecified

***Laboratory evidence of HIV***

[MA14.0](#)

Laboratory evidence of human immunodeficiency virus

***Certain injuries***

**Certain disorders due to substance use or addictive behaviours**

	Head	Neck	Thorax	Abdomen	Upper arm	Forearm	Wrist Hand	Hip	Lower leg	Ankle Foot
Open wound	<a href="#">NA01</a>	<a href="#">NA21</a>	<a href="#">NA81</a>	<a href="#">NB51</a>	<a href="#">NC11</a>	<a href="#">NC31</a>		<a href="#">NC71</a>	<a href="#">NC91</a>	
Fracture	<a href="#">NA02</a>	<a href="#">NA22</a>	<a href="#">NA82</a>	<a href="#">NB52</a>	<a href="#">NC12</a>	<a href="#">NC32</a>		<a href="#">NC72</a>	<a href="#">NC92</a>	
Injury of blood vessels	<a href="#">NA05</a>	<a href="#">NA60</a>		<a href="#">NB90</a>	<a href="#">NC15</a>	<a href="#">NC35</a>	<a href="#">NC56</a>	<a href="#">NC75</a>	<a href="#">NC95</a>	<a href="#">ND16</a>
Injury of organs				<a href="#">NB91</a> <a href="#">NB92</a>						
Crushing injury	<a href="#">NA08</a>	<a href="#">NA62</a>	<a href="#">NB33</a>	<a href="#">NB93</a>	<a href="#">NC17</a>	<a href="#">NC37</a>	<a href="#">NC58</a>	<a href="#">NC77</a>	<a href="#">NC97</a>	<a href="#">ND18</a>
Traumatic amputation	<a href="#">NA09</a>	<a href="#">NA63</a>	<a href="#">NC18</a>	<a href="#">NC38</a>	<a href="#">NC59</a>	<a href="#">NC78</a>	<a href="#">NC98</a>	<a href="#">ND19</a>		
Laceration of muscle, fascia or tendon	<a href="#">NA0A.11</a>	<a href="#">NA61.1</a>	<a href="#">NB34.1</a>	<a href="#">NB94.3</a> <a href="#">NB94.4</a> <a href="#">NB94.5</a>	<a href="#">NC16.01</a> <a href="#">NC16.11</a> <a href="#">NC16.21</a> <a href="#">NC16.31</a> <a href="#">NC16.41</a>	<a href="#">NC36.01</a> <a href="#">NC36.11</a> <a href="#">NC36.21</a> <a href="#">NC36.31</a> <a href="#">NC36.41</a> <a href="#">NC36.51</a>		<a href="#">NC76.01</a> <a href="#">NC76.11</a> <a href="#">NC76.21</a> <a href="#">NC76.31</a>	<a href="#">NC96.01</a> <a href="#">NC96.11</a> <a href="#">NC96.21</a> <a href="#">NC96.31</a>	
Multiple injuries	<a href="#">NA0A.3</a>	<a href="#">NA64</a>	<a href="#">NB35</a>	<a href="#">NB95</a> <a href="#">NB96</a>	<a href="#">NC19</a>	<a href="#">NC39</a>	<a href="#">NC5A</a>	<a href="#">NC79</a>	<a href="#">NC99</a>	<a href="#">ND1A</a>
Other or certain specified injuries	<a href="#">NA0A.0Y</a> <a href="#">NA0A.Y</a>	<a href="#">NA6Y</a>	<a href="#">NB3Y</a>	<a href="#">NB97</a> <a href="#">NB98</a> <a href="#">NB99</a> <a href="#">NB9Y</a>	<a href="#">NC1Y</a>	<a href="#">NC3Y</a>	<a href="#">NC5Y</a>	<a href="#">NC7Y</a>	<a href="#">NC9Y</a>	<a href="#">ND1Y</a>
Injuries, unspecified	<a href="#">NA0Z</a>	<a href="#">NA6Z</a>	<a href="#">NB3Z</a>	<a href="#">NB9Z</a>	<a href="#">NC1Z</a>	<a href="#">NC3Z</a>	<a href="#">NC5Z</a>	<a href="#">NC7Z</a>	<a href="#">NC9Z</a>	<a href="#">ND1Z</a>

	Multiple body injuries	Unspecified part of trunk, limb etc.	Arm	Leg	Unspecified body region
Superficial injury			<a href="#">ND53.Y</a>	<a href="#">ND55</a>	
Open wound	<a href="#">ND31</a>	<a href="#">ND51.Y</a>	<a href="#">ND53.Y</a>	<a href="#">ND55</a>	<a href="#">ND56.1</a>
Fracture	<a href="#">ND32</a>	<a href="#">ND50</a> (Spine)	<a href="#">ND52</a>	<a href="#">ND54</a>	<a href="#">ND56.2</a>
Dislocations, strains or sprains	<a href="#">ND33</a>		<a href="#">ND53.Y</a>	<a href="#">ND55</a>	
Crushing injury	<a href="#">ND34</a>			<a href="#">ND55</a>	<a href="#">ND56.7</a>
Traumatic amputation	<a href="#">ND35</a>	<a href="#">ND51.Y</a>	<a href="#">ND53.Y</a>	<a href="#">ND55</a>	<a href="#">ND56.8</a>
Other specified injuries	<a href="#">ND36</a>	<a href="#">ND51.Y</a>	<a href="#">ND53.Y</a>	<a href="#">ND55</a>	<a href="#">ND56.5</a> (Blood vessel) <a href="#">ND56.Y</a>
Injuries, unspecified	<a href="#">ND37</a>	<a href="#">ND51.Z</a>	ND53.Z	<a href="#">ND55</a>	<a href="#">ND56.Z</a>

***Certain injuries (continued)***

ND70-ND7Z	Effects of foreign body entering through natural orifice
ND90-NE2Z	Burns
<a href="#">NE80</a>	Injury or harm arising following infusion, transfusion or therapeutic injection, not elsewhere classified

***Certain causes of healthcare related harm or injury***

PK80-PK8Z	Surgical or other medical procedures associated with injury or harm in diagnostic or therapeutic use
<a href="#">PL11.0</a>	Cut, puncture or tear, as mode of injury or harm
<a href="#">PL11.4</a>	Failure of sterile precautions, as mode of injury or harm
<a href="#">PL14.4</a>	Other problem associated with transfusion

3.14.8 List of conditions that can cause diabetes mellitus

This list to be used to support the Special instructions on accepted and rejected sequences Steps SP3-SP4 to assess the sequence for deaths where diabetes mellitus is reported on the death certificate.



**5A10 Type 1 diabetes mellitus**

[1D82.1](#)

Cytomegaloviral pancreatitis

[5B52](#)

Acute malnutrition in infants, children or adolescents

[5B71](#)

Protein deficiency

[5B7Z](#)

Unspecified undernutrition

**5A11 Type 2 diabetes mellitus**

[5A70](#)

Cushing syndrome

[5B52](#)

Acute malnutrition in infants, children or adolescents

[5B71](#)

Protein deficiency

[5B7Z](#)

Unspecified undernutrition

**5A12 Malnutrition-related diabetes mellitus**

[5B52](#)

Acute malnutrition in infants, children or adolescents

[5B71](#)

Protein deficiency

[5B7Z](#)

Unspecified undernutrition

**5A13 Diabetes mellitus, other specified type or [5A14](#) Diabetes mellitus, type unspecified**

[1D82.1](#)

Cytomegaloviral pancreatitis

[1D80.4](#)

Pancreatitis due to mumps virus

[2C10](#)

Malignant neoplasm of pancreas

[2D81](#)

Malignant neoplasm metastasis in pancreas

[2E92.8](#)

Benign neoplasm of pancreas

[2E92.9](#)

Benign neoplasm of endocrine pancreas

4A40-4A4Z

Nonorgan specific systemic autoimmune disorders

[5A02](#)

Thyrotoxicosis

[5A03](#)

Thyroiditis

[5A60.0](#)

Acromegaly or pituitary gigantism

[5A70](#)

Cushing syndrome

[5B52](#)

Acute malnutrition in infants, children or adolescents (*for [5A14](#) only*)

[5B71](#)

Protein deficiency (*for [5A14](#) only*)

[5B7Z](#)

Unspecified undernutrition (*for [5A14](#) only*)

[5C58.1](#)

Porphyrias

[5C64.1](#)

Disorders of iron metabolism

### **5A10 Type 1 diabetes mellitus**

<a href="#">5D41</a>	Postprocedural hypoinsulinaemia
<a href="#">6C40.1</a>	Harmful pattern of use of alcohol
<a href="#">6C40.2</a>	Alcohol dependence
<a href="#">8A01.10</a>	Huntington disease
<a href="#">8A03</a>	Ataxic disorders
<a href="#">8A0Z</a>	Movement disorders, unspecified
<a href="#">8C71</a>	Myotonic disorders
<a href="#">CA25</a>	Cystic fibrosis
<a href="#">DC31</a>	Acute pancreatitis
<a href="#">DC32</a>	Chronic pancreatitis
<a href="#">DC3Z</a>	Diseases of pancreas, unspecified
<a href="#">JA63.2</a>	Diabetes mellitus arising in pregnancy
<a href="#">KA62.8</a>	Congenital rubella syndrome
LD20-LD2Z	Multiple developmental anomalies or syndromes
<a href="#">LD40.0</a>	Complete trisomy 21
<a href="#">LD50.0</a>	Turner syndrome
<a href="#">LD50.3</a>	Klinefelter syndrome
<a href="#">LD52.1</a>	Male with double or multiple Y
<a href="#">LD53</a>	Structural anomalies of chromosome Y
<a href="#">LD54</a>	Male with sex chromosome mosaicism
<a href="#">LD5Y</a>	Other specified sex chromosome anomalies
<a href="#">LD7Y</a>	Other specified chromosomal anomalies, excluding gene mutations
<a href="#">NB91.4</a>	Injury of pancreas
<a href="#">NE60</a>	Harmful effects of drugs, medicaments or biological substances, not elsewhere classified
<a href="#">PL00</a>	Drugs, medicaments or biological substances associated with injury or harm in therapeutic use

#### 3.14.9 List of conditions to be considered obvious consequences of surgery and other invasive medical procedures

The list in this section contains conditions that might develop as complications to surgery or other invasive medical procedures. This does not mean that the conditions on the list should always be considered as complications, and the following restrictions apply:

- Do not consider a condition on the list as a complication of a surgery or an invasive medical procedure if the surgery or procedure was carried out more than four weeks before death.

- Do not consider a condition on the list as a complication of a surgery or an invasive procedure if there is evidence that the condition was present before the surgery or invasive procedure was carried out.
- Do not consider a condition flagged with '**OCPR (Other Cause of Procedure Required)**' as a complication of surgery or an invasive procedure unless the certificate reports another condition of the same site that was treated by surgery or some other invasive procedure.
- Do not consider a condition flagged with '**DSAP (Duration Stated, developed After Procedure)**' as a complication unless there is clear evidence that the condition developed after the surgery or invasive procedure.
- Note that adhesions should be considered as complications of surgery or an invasive procedure in the same site or region, even after more than four weeks since the date of the surgery or invasive procedure. If the procedure was performed more than one year before death, use the codes for sequelae of medical care.

### **3.14.9.1 List of conditions to be considered direct consequences of surgery**

<b>Infections</b>	<b>Flag</b>
Abscess	OCPR
Bacteraemia	
Fistula	OCPR, and for a procedure of the same site or region only
Gas gangrene	
Infection, haemolytic	
Infection NOS	DSAP
Infection in surgical wound	
Sepsis	
Septic	
<b>Haemorrhage, haemolysis</b>	<b>Flag</b>
Coagulopathy, consumption	
Disseminated intravascular coagulation (DIC)	
Haemorrhage NOS	
Haemorrhage, gastrointestinal	OCPR
Haemorrhage, intra-abdominal	OCPR
Haemorrhage, rectal	OCPR
Haemorrhage, surgical wound	
haemorrhage, specified site	For a procedure of the same site or region only
Haematemesis	OCPR
Haematoma	OCPR
Haemothorax	OCPR
Haemolysis	
Melaena	OCPR
<b>Cardiac complications</b>	<b>Flag</b>
Arrest, cardiac	
Arrhythmia NOS	DSAP
Asystole	
Block, cardiac	DSAP
Failure/insufficiency, cardiac	
Fibrillation, atrial	DSAP
Fibrillation, ventricular	
Infarction (myocardial)	
Ischaemia, myocardial (acute)	
Rupture, myocardial	

<b>Infections</b>	<b>Flag</b>
<b>Cerebrovascular and other cerebral complications</b>	<b>Flag</b>
Apoplexy	DSAP
Damage, brain (anoxic)	DSAP
Embolism, cerebral	DSAP
Haemorrhage, cerebral/intracranial	DSAP
Infarction, cerebral	DSAP
Ischaemia, cerebral/cerebrovascular	DSAP
Lesion, cerebral/cerebrovascular	DSAP
Meningitis	DSAP
Oedema, cerebral	DSAP
Stroke	DSAP
Thrombosis, cerebral	DSAP
<b>Other vascular complications</b>	<b>Flag</b>
Arrest, circulatory	
Embolism (arterial)	
Embolism, fat/air	
Embolism, air	
Embolism, pulmonary	
Embolism, venous	
Failure/insufficiency, circulatory	
Hypotension	
Infarction, pulmonary	
Infarction (any site)	
Occlusion (any site)	
Phlebitis (any site)	
Phlebothrombosis (any site)	
Thrombophlebitis (any site)	
Thrombosis, arterial	
Thrombosis, venous	
Thrombosis NOS (any site)	
<b>Respiratory complications</b>	<b>Flag</b>
Adult respiratory distress syndrome (ARDS)	
Alkalosis and acidosis, respiratory	
Arrest, respiratory	
Aspiration	
Atelectasis	

<b>Infections</b>	<b>Flag</b>
Bronchitis	DSAP
Effusion, pleura	
Empyema	OCPR
Fistula, bronchopleural or oesophageal	OCPR
Failure/insufficiency, pulmonary	
Failure/insufficiency, respiratory	
Mediastinitis	
Obstruction, upper airway	OCPR
Oedema, laryngeal	OCPR
Oedema/hypostasis, pulmonary	
Pneumonia	
Pneumothorax	OCPR
<b>Gastrointestinal complications</b>	<b>Flag</b>
Abscess, intra-abdominal	OCPR
Constipation	OCPR
Dilatation, gastric	OCPR
Disorder, circulatory, gastrointestinal	OCPR
Embolism, mesenterial	OCPR
Failure, hepatic	DSAP
Fistula, biliary/ bowel/rectovaginal	OCPR
Ileus	OCPR
Ischaemia, intestinal	OCPR
Necrosis, gastrointestinal	OCPR
Obstruction, bowel (mechanical)	OCPR
Peritonitis	OCPR
Ulcer, gastrointestinal (stress)	OCPR
Volvulus	OCPR
<b>Renal and urinary complications</b>	<b>Flag</b>
Anuria	
Failure/insufficiency, renal	
Fistula, urinary	OCPR
Infection, urinary	
Pyelonephritis	DSAP
Retention, urine	
Stricture, urethra	OCPR
Uraemia	
Urosepsis	

<b>Infections</b>	<b>Flag</b>
<b>Other complications</b>	<b>Flag</b>
Adhesions	For a procedure of the same site or region only
Compartment syndrome	OCPR
Complication(s) NOS	
Crisis, thyrotoxic	DSAP
Displacement, prosthesis	
Failure, (multi)organ	
Gangrene	
Insufficiency, anastomosis	OCPR
Necrosis, fat/wound	OCPR
Seizures (epileptic)	DSAP
Shock NOS	
Shock, anaphylactic	
Ulcer, decubitus	

### **3.14.9.2 List of conditions to be considered direct consequences of other invasive medical procedures**



**Obvious consequences of cardiac catheterization** [PK80.11](#)

Cardiac procedure for repair of congenital anomaly associated with injury or harm, percutaneous approach, [PK80.15](#) Other cardiac procedure associated with injury or harm, percutaneous approach

Sepsis, septic shock

Bacteraemia

MRSA

Fungal sepsis

Fungaemia

Vascular catheter or port infection

Septic thrombophlebitis

Infectious endocarditis

Myocardial infarction

Only if indicated as following the catheterization

Coronary thrombosis

Only if indicated as following the catheterization

Coronary embolism

Only if indicated as following the catheterization

Coronary rupture

Only if indicated as following the catheterization

Cardiac arrest

Cardiac embolism

Cholesterol embolic syndrome

Pulmonary embolism

Haemorrhage

Blood loss

Haemoperitoneum

Cardiogenic shock

Only if indicated as following the catheterization

Hypotensive shock

Only if indicated as following the catheterization

**Obvious consequences of aspiration of fluid** [PK81.2](#) Aspiration or drainage of body cavity or fluid collection associated with injury or harm in therapeutic use

Haemothorax

If aspiration or puncture of the same site

Haemorrhage

If aspiration or puncture of the same site

**Obvious consequences of biopsy** [PK81.4](#) Bone marrow aspiration or biopsy associated with injury or harm in therapeutic use, [PK81.5](#) Biopsy procedure, not elsewhere classified, associated with injury or harm in therapeutic use

Haemorrhage

If of the same site

Pneumothorax

If of the same site

Adhesions

If of the same site

**Obvious consequences of kidney dialysis** [PK81.6](#) Dialysis associated with injury or harm in therapeutic use

Sepsis, septic shock

Bacteraemia

MRSA

Infectious endocarditis

Fungal sepsis

Fungaemia

Vascular catheter or port infection

Septic thrombophlebitis

Peritonitis

Pneumonia

Hypotension (during dialysis)

Hypovolemic shock

Haemorrhage

**Obvious consequences of feeding tube, PEG** [PK81.8](#) Insertion of tube associated with injury or harm in therapeutic use

Aspiration pneumonia

Abdominal wound infection

Abdominal wall infection

**Obvious consequences of resuscitation** [PK81.E](#) Cardiopulmonary resuscitation associated with injury or harm in therapeutic use

Rib fracture(s)

**Other surgical or medical procedures** [PK8Y](#) Other specified surgical or other medical procedures associated with injury or harm in diagnostic or therapeutic use

**Obvious consequences of Intravenous line/artery catheter**

Sepsis, septic shock

Bacteraemia

MRSA

Fungal sepsis

Fungaemia

Vascular catheter or port infection

Septic thrombophlebitis

If infection of catheter/port site

Infectious endocarditis

If infection of catheter/port site

Cellulitis

If infection of catheter/port site

Abscess

If infection of catheter/port site

Haematoma

If infection of catheter/port site

Haemorrhage

If infection of catheter/port site

Haemothorax

If infection of catheter/port site

**Obvious consequences of bone marrow transplant**

Sepsis, septic shock

Bacteraemia

MRSA

Fungal sepsis

Fungaemia

Necrotizing fasciitis

Thrombocytopenia

Graft vs host disease

**Obvious consequences of radiological procedures and therapy**

Pericarditis	If radiation of the same site
Restrictive lung disease	If radiation of the same site
Small bowel obstruction	If radiation of the same site
Cervical myelitis	If radiation of the same site
(Interstitial) fibrosis	If radiation of the same site
Osteonecrosis	If radiation of the same site
Mucositis	If radiation of the same site
Fistula	If radiation of the same site
Stricture or scarring	If radiation of the same site

**Obvious consequences of urinary catheterization [PK93.10](#)**

Gastroenterology or urology devices associated with injury or harm, urinary catheter

Urinary tract infection

Urosepsis

**3.14.10 List of conditions unlikely to cause death**

Use this table in Step SP8 Conditions in this table are unlikely to cause death.

[Unlikely to cause death](#)

### 3.14.11 List of categories limited to, or more likely to occur in, female persons

Code	Title
<a href="#">1C14</a>	Obstetrical tetanus
<a href="#">1F23.10</a>	Vulvovaginal candidosis
<a href="#">2B58.1</a>	Leiomyosarcoma of uterus
<a href="#">2B5C</a>	Endometrial stromal sarcoma, primary site
<a href="#">2B5D.0</a>	Malignant mixed epithelial mesenchymal tumour of ovary
<a href="#">2B5D.1</a>	Malignant mixed epithelial and mesenchymal tumour of corpus uteri
<a href="#">2B5F.0</a>	Sarcoma, not elsewhere classified of uterus
<a href="#">2B5G</a>	Myosarcoma of uterus, part not specified
<a href="#">2C65</a>	Hereditary breast and ovarian cancer syndrome
2C70-2C7Z	Malignant neoplasms of female genital organs
<a href="#">2E05</a>	Malignant neoplasm metastasis in female reproductive system
<a href="#">2E66</a>	Carcinoma in situ of cervix uteri
<a href="#">2E67.0</a>	Carcinoma in situ of endometrium
<a href="#">2E67.1</a>	Carcinoma in situ of vulva
<a href="#">2E67.2</a>	Carcinoma in situ of vagina
<a href="#">2E67.3</a>	Carcinoma in situ of other or unspecified female genital organs
<a href="#">2E86.0</a>	Leiomyoma of uterus
<a href="#">2E88</a>	Benign endometrial stromal tumour
<a href="#">2F31</a>	Non-mesenchymal benign neoplasms of uterus
<a href="#">2F32</a>	Benign neoplasm of ovary
<a href="#">2F33</a>	Benign neoplasm of other or unspecified female genital organs
<a href="#">2F76</a>	Neoplasms of uncertain behaviour of female genital organs
<a href="#">2F96</a>	Neoplasms of unknown behaviour of female genital organs
<a href="#">4A45.2</a>	Antiphospholipid syndrome in pregnancy
<a href="#">5A71.0</a>	46,XX disorders of sex development induced by androgens of foetal origin
<a href="#">5A71.1</a>	46,XX disorders of sex development induced by androgens of maternal origin
<a href="#">5A80</a>	Ovarian dysfunction
<a href="#">5D44</a>	Postprocedural ovarian failure
<a href="#">6E20</a>	Mental or behavioural disorders associated with pregnancy, childbirth and the puerperium, without psychotic symptoms
<a href="#">6E21</a>	Mental or behavioural disorders associated with pregnancy, childbirth or the puerperium, with psychotic symptoms
<a href="#">6E2Z</a>	Mental or behavioural disorders associated with pregnancy, childbirth and the puerperium, unspecified
<a href="#">BD75.2</a>	Vulval varices
<a href="#">EA83.00</a>	Lichen simplex of vulva
<a href="#">EA87.1</a>	Dermatitis or eczema of female genitalia

Code	Title
<a href="#">EB60.0</a>	Lichen sclerosus of vulva
<a href="#">ED61.11</a>	Vulval melanotic macule
<a href="#">ED70.1</a>	Female pattern hair loss
<a href="#">ED70.31</a>	Postpartum telogen effluvium
<a href="#">EE40.10</a>	Stretch marks of pregnancy
<a href="#">EK02.13]</a>	Irritant contact dermatitis of vulva
<a href="#">FB83.10</a>	Premenopausal idiopathic osteoporosis
<a href="#">FB83.11</a>	Postmenopausal osteoporosis
<a href="#">FC01.9</a>	Postoophorectomy osteoporosis
GA00- GA6Z	Diseases of the female genital system
<a href="#">GB23.4</a>	Galactorrhoea not associated with childbirth
<a href="#">GC04.1</a>	Fistulae involving female genital tract
<a href="#">GC04.2</a>	Ureteral fistula
GC40- GC4Z	Female pelvic floor dysfunction
<a href="#">GC50.10</a>	Absent or diminished bladder sensation associated with pelvic organ prolapse
<a href="#">GC51</a>	Female Genital Mutilation
<a href="#">GC70</a>	Postoperative adhesions of vagina
<a href="#">GC71</a>	Prolapse of vaginal vault after hysterectomy
<a href="#">GC77</a>	Postprocedural nonmenstrual uterine bleeding
<a href="#">GC78</a>	Postprocedural acute female pelvic inflammatory disease
<a href="#">HA01.0</a>	Female sexual arousal dysfunction
<a href="#">HA20</a>	Sexual pain-penetration disorder
JA00-JB6Z	Pregnancy, childbirth or the puerperium
<a href="#">KA83.9</a>	Neonatal vaginal or uterine haemorrhage
<a href="#">LA90.32</a>	Uterine arteriovenous malformations
LB40-LB4Z	Structural developmental anomalies of the female genital system
<a href="#">LD2A.1</a>	46,XY gonadal dysgenesis
<a href="#">LD2A.4</a>	46,XY disorder of sex development due to androgen resistance
<a href="#">LD50.0</a>	Turner syndrome
<a href="#">LD50.1</a>	Karyotype 47,XXX
<a href="#">LD50.2</a>	Mosaicism, lines with various numbers of X chromosomes
<a href="#">LD50.Y</a>	Other specified number anomalies of chromosome X
<a href="#">LD50.Z</a>	Number anomalies of chromosome X, unspecified
<a href="#">LD90.4</a>	Rett syndrome

Code	Title
MF30- MF3Y	Symptoms, signs or clinical findings involving the female genital system
MF60- MF6Z	Clinical findings in specimens from female genital organs
<a href="#">MG24.01</a>	Fear of breast cancer female
<a href="#">MG24.D</a>	Fear of complications of pregnancy
<a href="#">MG24.E</a>	Fear of sexually transmitted disease female
<a href="#">MG24.F</a>	Fear of female genital or breast disease
<a href="#">NB92.4</a>	Injury of ovary
<a href="#">NB92.5</a>	Injury of fallopian tube
<a href="#">NB92.6</a>	Injury of uterus
<a href="#">NB93.02</a>	Crushing injury of vulva
<a href="#">NB93.24</a>	Traumatic amputation of entire vulva
<a href="#">NB93.25</a>	Traumatic amputation of part of vulva
<a href="#">NB98</a>	Injury to female genital organ without further specification
<a href="#">ND56.9</a>	Injury complicating pregnancy
<a href="#">ND74.2</a>	Foreign body in vulva or vagina
<a href="#">ND74.3</a>	Foreign body in uterus, any part
<a href="#">PK80.5</a>	Gynaecological or breast procedure associated with injury or harm in therapeutic use
<a href="#">PK80.7</a>	Obstetric procedure associated with injury or harm in therapeutic use
<a href="#">PK96</a>	Obstetric or gynaecological devices, implants or grafts associated with injury or harm
<a href="#">QA00.9</a>	Gynaecological examination
<a href="#">QA09.4</a>	Special screening examination for neoplasm of cervix
<a href="#">QA21.0</a>	Contact with health services for postcoital contraception
<a href="#">QA21.2</a>	Contact with health services for insertion of contraceptive device
<a href="#">QA21.4</a>	Contact with health services for menstrual extraction
<a href="#">QA21.6</a>	Surveillance of contraceptive device
<a href="#">QA30.00</a>	Contact with health services for gamete intrafallopian transfer
<a href="#">QA30.01</a>	Contact with health services for procreative management by artificial insemination
<a href="#">QA30.02</a>	Contact with health services for medically assisted sperm insemination
<a href="#">QA30.0Y</a>	Contact with health services for other specified assisted insemination
<a href="#">QA30.0Z</a>	Contact with health services for unspecified assisted insemination
<a href="#">QA30.1</a>	Contact with health services for assisted reproductive technology
<a href="#">QA30.2</a>	Contact with health services for other assisted fertilisation methods



Code	Title
<a href="#">QA30.Y</a>	Other specified contact with health services for medically assisted reproduction
<a href="#">QA40</a>	Pregnancy examination or test
<a href="#">QA41</a>	Pregnant state
<a href="#">QA42</a>	Supervision of normal pregnancy
<a href="#">QA43</a>	Supervision of high-risk pregnancy
<a href="#">QA45</a>	Antenatal screening
<a href="#">QA46</a>	Outcome of delivery
<a href="#">QA48</a>	Postpartum care or examination
<a href="#">QA49</a>	Problems related to unwanted pregnancy
<a href="#">QA4A</a>	Problems related to multiparity
<a href="#">QA4B</a>	Contact with health services for menopausal counselling
<a href="#">QB51.C</a>	Presence of contraceptive device
<a href="#">QB62.5</a>	Attention to artificial vagina
<a href="#">QD31</a>	Contact with health services for concerns about body image related to pregnancy
<a href="#">QF01.10</a>	Acquired absence of female genital organs

#### 3.14.12 List of categories limited to, or more likely to occur in, male persons

Code	Title
<a href="#">1A70.00</a>	Gonorrhoea of penis
<a href="#">1D80.1</a>	Orchitis due to mumps virus
<a href="#">1F23.11</a>	Candida balanoposthitis
<a href="#">2B55.2</a>	Rhabdomyosarcoma of male genital organs
<a href="#">2B59.2</a>	Liposarcoma of male genital organs
2C80-2C8Z	Malignant neoplasms of male genital organs
<a href="#">2E06</a>	Malignant neoplasm metastasis in male genital organs
<a href="#">2E67.4</a>	Carcinoma in situ of penis
<a href="#">2E67.5</a>	Carcinoma in situ of prostate
<a href="#">2E67.6</a>	Carcinoma in situ of other or unspecified male genital organs
<a href="#">2F34</a>	Benign neoplasm of male genital organs
<a href="#">2F77</a>	Neoplasms of uncertain behaviour of male genital organs
<a href="#">2F97</a>	Neoplasms of unknown behaviour of male genital organs
<a href="#">5A81</a>	Testicular dysfunction or testosterone-related disorders
<a href="#">5D45</a>	Postprocedural testicular hypofunction
<a href="#">BD75.1</a>	Scrotal varices
<a href="#">EA83.01</a>	Lichen simplex of male genitalia
<a href="#">EA87.0</a>	Dermatitis or eczema of male genitalia
<a href="#">EB60.1</a>	Lichen sclerosus of penis
<a href="#">EC92.0</a>	Penoscrotodynia
<a href="#">ED61.10</a>	Penile melanotic macule
GA80-GB0Z	Diseases of the male genital system
<a href="#">HA01.1</a>	Male erectile dysfunction
<a href="#">HA03</a>	Ejaculatory dysfunctions
LB50-LB5Z	Structural developmental anomalies of the male genital system
<a href="#">LD2A.0</a>	Ovotesticular disorder of sex development
<a href="#">LD2A.2</a>	Testicular agenesis
<a href="#">LD2A.3</a>	46,XY disorder of sex development due to a defect in testosterone metabolism
<a href="#">LD50.3</a>	Klinefelter syndrome
<a href="#">LD52</a>	Number anomalies of chromosome Y
<a href="#">LD53</a>	Structural anomalies of chromosome Y
<a href="#">LD54</a>	Male with sex chromosome mosaicism
<a href="#">MA14.1B</a>	Prostate specific antigen positive
MF40- MF4Y	Symptoms, signs or clinical findings involving the male genital system

Code	Title
MF70- MF7Z	Clinical findings in specimens from male genital organs
<a href="#">MG24.02</a>	Fear of genital cancer male
<a href="#">MG24.G</a>	Fear of sexually transmitted disease male
<a href="#">MG24.H</a>	Fear of genital disease male
<a href="#">NB93.00</a>	Crushing injury of penis
<a href="#">NB93.01</a>	Crushing injury of testes or scrotum
<a href="#">NB93.20</a>	Traumatic amputation of entire penis
<a href="#">NB93.21</a>	Traumatic amputation of part of penis
<a href="#">NB93.22</a>	Traumatic amputation of entire testes or scrotum
<a href="#">NB93.23</a>	Traumatic amputation of part of testes or scrotum
<a href="#">NB97.1</a>	Fractured penis
<a href="#">NB99</a>	Injury to male genital organ without further specification
<a href="#">QA09.5</a>	Special screening examination for neoplasm of prostate
<a href="#">QB82</a>	Contact with health services for routine or ritual circumcision
<a href="#">QF01.11</a>	Acquired absence of male genital organs

### 3.14.13 Collection of instructions with coding examples related maternal mortality

*Overview (See Section [2.21.8.2](#))*

The International form of medical certificate of cause of death (See Mortality Annex [3.14](#) is structured to allow reporting on obstetric causes, the time elapsed between the obstetric event and the person's death, and whether the pregnancy contributed to death. Use all information available on the death certificate. When information provided is ambiguous it is recommended to verify where possible, while means of verification may vary among countries according to different legal systems or profiles in maternal mortality. Additional information may be obtained through clinical summaries of medical institutions, verbal autopsy reports, or by certain verification processes which may require not only queries to the certifier but also establishing an inquiry system to analyse specific cases.

Following concepts related to statistical tabulation of maternal mortality is provided in Section [2.25.5](#) Standards and reporting requirements related for maternal mortality.

- [2.25.5.1](#) Maternal death
- [2.25.5.2](#) Late Maternal death
- [2.25.5.3](#) Comprehensive maternal death
- [2.25.5.4](#) Direct and indirect obstetric deaths
- [2.25.5.5](#) Death occurring during pregnancy, childbirth and puerperium
- [2.25.5.6](#) Recording requirements of maternal mortality
- [2.25.5.7](#) International reporting of maternal mortality
- [2.25.5.8](#) Numerator, denominator, and ratios of published maternal mortality

Briefly the underlying cause of death categories for Maternal Mortality is summarized in the table below:

	<a href="#">J000 -J060, J063.-, J064.-, J06Y, 1C14</a> <b>Maternal death</b>	<a href="#">J061.-</a> <b>Late Maternal death</b>	<a href="#">J062.-</a> <b>Sequealae of obstetric conditions</b>
Deceased was pregnant:	at the time of death, and within 42 days before the death	more than 42 days but less than one year before the death	one year or more before the death

On a death certificate usually the timespan is recorded in day unit where 42 days are included in maternal death and 43 days are included in late maternal death. In a mathematical explanation, this means exactly 42 days are included in maternal death, while for example 42 days and one hour is included in late maternal death. Also note that [J061.-](#) and [J062.-](#) includes deaths due to any obstetric cause. The obstetric cause reported including cause unknown ([J060](#)) is postcoordinated to [J061.-](#) or [J062.-](#) to retain information on the cause. Coding instructions are provided to select the UCOD and capture further details in a cluster.

### ***Coding instructions for maternal mortality***

For coding of maternal mortality, follow the general coding instructions.

To assign the correct multiple cause code for a certificate with mention of pregnancy, first use the coding tool to assign a specific code for each condition reported. Categories out of Chapter 18 may also be assigned. When a condition suggests it is an obstetric condition, by using certain modifiers such as 'obstetric' or 'maternal', search if there is a direct match of the diagnosis reported. The coding tool also supports coding by providing the icon 'J' ( ) for certain condition that have a compatible category for maternal conditions.

### Example 1

- 1 (a) Pulmonary oedema [CB01](#)
  - (b) Mitral valve insufficiency, pregnancy [JB64.4/BB61.Z](#)
  - (c)
  - (d)
- 2

Mitral valve insufficiency nos is coded to [BB61.Z](#), however assign [JB64.4/BB61.Z](#) because it is described as 'pregnancy'.

### Example 2

- 1 (a) Pulmonary oedema [CB01](#)
  - (b) Mitral valve insufficiency [BB61.Z](#)
  - (c)
  - (d)
- 2 XX completed weeks of gestation

Code mitral valve insufficiency to [BB61.Z](#). Pregnancy is mentioned in Part 2 and it is considered that pregnancy contributed to death. Apply Step M4 and code the underlying cause of death to [JB64.4](#) Diseases of the circulatory system complicating pregnancy, childbirth or the puerperium. For greater specificity, also add the code for [BB61.Z](#) Mitral valve insufficiency, unspecified to the cluster ([JB64.4/BB61.Z](#)).

### **Structure of Chapter 18 and other related categories**

The following categories are used for deaths due to an obstetric event occurring within 42 days after termination of pregnancy:

- [JA00 - JB4Z, 1C14](#): Direct obstetric causes
- [JB63.-, JB64.-](#): Maternal diseases classifiable elsewhere but complicating pregnancy
- [JB60](#) is used when a woman dies during pregnancy, labor, delivery or the puerperium and the only information provided is 'maternal' or 'obstetric' death. If obstetric cause of death is specified, do not use [JB60](#) but code to the appropriate category.
- [JB6Y](#) is used for other specified obstetric conditions not elsewhere classified

Category [JB61.-](#) is used for death of a woman due to an obstetric cause but more than 42 days but less than one year after termination of pregnancy.

Category [JB62.-](#) is used for death of a woman due to an obstetric cause of one year or more after termination of pregnancy.

[JB6Z](#) is used when both obstetric condition is unspecified, and the time elapsed between the obstetric event and death is unknown. Note that this code is not to be used for underlying cause of death (See section [2.19.4](#) Special instructions on surgery and other medical procedures (Step M4)) .

### **Determining whether pregnancy contributed to death**

Consider pregnancy contribute to death when pregnancy, puerperium or childbirth is reported in Part 1 or Part 2; or is reported elsewhere and the answer to the question “Did the pregnancy contribute to death?” is yes, unknown, or is unstated.

### ***Determining the time elapsed***

The time elapsed between the obstetric event and the death is determined by the duration reported for the obstetric cause. If duration is unknown or unspecified, use the information in Frame B of the death certificate. When duration is unknown or unstated, but pregnancy contributed to death, it is assumed that the death occurred within 42 days after the obstetric event.

### **Selecting the underlying cause of death for maternal mortality (See Section [2.19.7](#))**

For coding of maternal mortality, follow general coding instructions.

After assigning a code for each condition reported (See Coding instructions for maternal mortality in Section [2.21.8.2](#)) apply the selection and modification instructions in the normal way starting from SP1 as same as other causes of death.

Then, apply Steps SP1 to SP8 and M1 to M3 and M4 for Surgery, Injury, External causes, and Poisoning, then Step M4 for maternal mortality (See also section [2.19.7](#)).

### ***Typical cases of maternal mortality***

Normally the sequence reported is accepted in general (See Section [2.16.2](#)), however, several relations may be rejected, and may have other specific instructions as summarized below.

Example 3		Duration
1	(a) Hypovolemic shock	1 hour
	(b) Postcesarean hemorrhage	2 hours
	(c) Uterine vessel injury during cesarean section	2 hours
	(d)	
2		

The deceased was pregnant: Yes, within 42 days of death; Pregnancy contributed to death: Yes

Both hypovolemic shock and postcaesarean hemorrhage can be caused by Uterine vessel injury during cesarean section coded to [JBOD.3](#) Other complications of obstetric surgery or procedures and is the tentative starting point (Step SP3). As no other special instruction apply, and the death was within 42 days after the obstetric cause, [JBOD.3](#) is the underlying cause of death.

#### Example 4

- 1 (a) Pulmonary oedema [CB01](#)
  - (b) Mitral valve insufficiency, pregnancy [JB64.4/BB61.Z](#)
  - (c)
  - (d)
- 2

Pulmonary oedema can be caused by mitral regurgitation in pregnancy which is the tentative starting point (Step SP3). As no other special instruction apply, and the death was within 42 days of after the obstetric cause, [JB64.4](#) is the underlying cause of death. For greater specificity, also add the code for [BB61.Z](#) Mitral valve insufficiency, unspecified to the cluster ([JB64.4/BB61.Z](#)).

#### Example 5

- 1 (a) Haemorrhage [MG27](#)
  - (b) Cervical cancer [2C77.Z](#)
  - (c)
  - (d)
- 2 Treatment delayed because of pregnancy

The deceased was pregnant: Yes, at the time of death; Pregnancy contributed to death: unstated

Cervical cancer is the tentative starting point (Step SP3). Pregnancy is mentioned in Part 2 and it is considered that pregnancy contributed to death. Apply Step M4 and code the underlying cause of death to [JB64.Y](#) Other specified maternal diseases classifiable elsewhere but complicating pregnancy, childbirth or the puerperium. For greater specificity, also add the code [2C77.Z](#) Malignant neoplasms of cervix uteri, unspecified to the cluster. ([JB64.Y/2C77.Z](#))

#### Example 6

- 1 (a) Hepatic failure [DB99.7](#)
  - (b) Dengue haemorrhagic fever 5 days [1D21](#)
  - (c)
  - (d)
- 2 Additional information: 40 days postpartum

The deceased was pregnant: Yes, within 42 days of death; Pregnancy contributed to death: unstated

Dengue with warning signs is the tentative starting point (Step SP3). Pregnancy is mentioned in Part 2 and it is considered that pregnancy contributed to death. Apply Step M4 and code the underlying cause to [JB63.5](#) Other viral diseases complicating pregnancy, childbirth or the puerperium. For greater specificity, also add the code for [1D21](#) Dengue with warning signs to the cluster. ([JB63.5 /1D21](#) )

Example 7

- 1 (a) Disseminated intravascular coagulation [3B20](#)
- (b) Obstetric hemorrhage [JA4Z](#)
- (c) Postpartum uterine atony [JA43.1](#)
- (d) Abruption placentae [JA8C.Z](#)

2

The deceased was pregnant: Yes, within 42 days of death; Pregnancy contributed to death:  
Yes

All DIC, obstetric hemorrhage, and postpartum uterine atony can be caused by Abruption placentae [JA8C.Z](#) and that is the tentative starting point. As DIC is reported and this gives greater specificity apply Step M2 and code to [JA8C.0](#) Premature separation of placenta with coagulation defect. As no other special instructions apply, and the death was within 42 days after the obstetric cause, [JA8C.0](#) is the underlying cause of death.

**Extraction and examples of special instructions on maternal mortality**

Followings are special instructions specific to categories in Chapter 18. For instructions of each step refer to corresponding sections.

SP3 & SP4 Accepted and rejected sequences of maternal mortality (see Section [2.17.6](#), [2.17.7](#) and [2.19.1.14](#))

Do not accept Ectopic pregnancy ([JA01.-](#)) and Molar pregnancy ([JA02.-](#)) as due to other causes.

<b>Consequence condition</b>	<b>Causal condition</b>
<a href="#">JA01.-</a> Ectopic pregnancy	<b>Do not accept</b> other causes
<a href="#">JA02.-</a> Molar pregnancy	

Do not accept Hypertensive disorders in pregnancy, childbirth, or the puerperium ([JA20-JA21](#), [JA23-JA25](#)) as due to other causes.

<b>Consequence condition</b>	<b>Causal condition</b>
<a href="#">JA20-JA21</a> , <a href="#">JA23-JA25</a> Hypertensive disorders in pregnancy, childbirth, or the puerperium	<b>Do not accept</b> other causes

Do not accept Maternal care related to placenta praevia or low lying placenta ([JA8B.-](#)) as due to other causes.

<b>Consequence condition</b>	<b>Causal condition</b>
<a href="#">JA8B.-</a> Maternal care related to placenta praevia or low lying placenta	<b>Do not accept</b> other causes



### Example 8

- 1 (a) Hypovolemic shock 1 day [MG40.1](#)
- (b) Obstetric haemorrhage 1 day [JA4Z](#)
- (c) Placenta praevia 1 day [JA8B.1](#)
- (d) Pneumonia 4 days [CA40.Z](#)

2

The deceased was pregnant: Yes, at the time of death; Pregnancy contributed to death: Yes

Placenta praevia cannot be caused by pneumonia and this sequence is rejected by the special instructions on the accepted and rejected sequence. There is an acceptable sequence which is hypovolemic shock caused by obstetric haemorrhage, in its turn caused by placenta praevia, and [JA8B.1](#) is the tentative starting point (Step SP4). As no other special instructions apply, and the death was within 42 days after the obstetric cause, [JA8B.1](#) is the underlying cause of death.

### SP5 - Terminal cause of death when no sequence (See Section [2.17.8](#))

### Example 9

- 1 (a) Amniotic fluid embolism [JB42.1](#)
- (b)
- (c)
- (d)

2

There is no sequencing ending with the terminal cause of death in Part one. Amniotic fluid embolism [JB42.1](#) is the tentative starting point (Step SP5), and as no other special instructions apply it is also the underlying cause of death.

SP8 - Conditions unlikely to cause death of maternal mortality (See Section [2.17.11](#) and Mortality Annex [3.14](#))

Code	Title
<a href="#">JA65.3</a>	Low weight gain in pregnancy
<a href="#">JA65.4</a>	Pregnancy care of habitual aborter
<a href="#">JA66</a> .-	Clinical findings on antenatal screening of mother
<a href="#">JA8D</a> .-	Maternal care related to false labour
<a href="#">JB00.0</a>	Preterm labour without delivery
<a href="#">JB46.0</a>	Retracted nipple associated with childbirth
<a href="#">JB46.2</a>	Other and unspecified disorders of breast associated with childbirth
<a href="#">JB46.3</a>	Agalactia
<a href="#">JB46.4</a>	Hypogalactia
<a href="#">JB46.5</a>	Suppressed lactation
<a href="#">JB46.6</a>	Galactorrhea
<a href="#">JB46.7</a>	Other and unspecified disorders of lactation

#### Example 10

1	(a) Galactorrhoea in puerperium	10 days	<a href="#">JB46.6</a>
	(b)		
	(c)		
	(d)		
2	Puerperal sepsis after cesarean section	6 days	<a href="#">JB40.0</a>

Galactorrhoea in puerperium [JB46.6](#) is the tentative starting point (Step SP5), but it is in the 'List of conditions considered unlikely to cause death'. There is another condition on the certificate, Puerperal sepsis after cesarean section, which is not in the 'List of conditions considered unlikely to cause death'. Disregard galactorrhoea in puerperium by Step SP8 and restart the selection procedure from Step SP1. Puerperal sepsis after cesarean section is selected as the underlying cause of death.

M1 – If the conditions specified in the right-hand column apply, then use the code in bold as the new tentative underlying cause (See Section [2.18.1](#) and [2.19.3](#))

*TUC is* with mention of: code to:  
[JA24](#).- Pre-eclampsia [JA25](#).- Eclampsia [JA25](#).-

<i>TUC is</i>		when reported as the cause of:	code to:
<a href="#">JA61.0</a> Varicose veins of lower extremity in pregnancy		<a href="#">JB42.2</a> Obstetric blood-clot embolism	<a href="#">JB42.2</a>
<a href="#">JA61.1</a> Genital varices in pregnancy			
<a href="#">JA61.2</a> Superficial thrombophlebitis in pregnancy			
<a href="#">JA61.4</a> Haemorrhoids in pregnancy			
 <i>TUC is</i>		when reported as the cause of:	code to:
<a href="#">JA65.2</a> Excessive weight gain in pregnancy		<a href="#">JA20 - JA20-JA2Z</a> Oedema, proteinuria, or hypertensive disorders in pregnancy, childbirth, or the puerperium	<a href="#">JA20 - JA20-JA2Z</a>
 <i>TUC is</i>		with mention of:	code to:
<a href="#">JA65.3</a> Low weight gain in pregnancy		<a href="#">JB64.2</a> Endocrine, nutritional or metabolic diseases complicating pregnancy, childbirth or the puerperium	<a href="#">JB64.2</a>
 <i>TUC is</i>		when reported as the cause of:	code to:
<a href="#">JA65.4</a> Pregnancy care of habitual aborter		<a href="#">JA00 - JA0Z</a> Abortive outcome of pregnancy	<a href="#">JA00 - JA0Z</a>
 <i>TUC is</i>		when reported as the cause of:	code to:
<a href="#">JA65.5</a> Retained intrauterine contraceptive device in pregnancy		<a href="#">JA00 - JA0Z</a> Abortive outcome of pregnancy	<a href="#">JA00 - JA0Z</a>
		<a href="#">JA88.1</a> Infection of amniotic sac and membranes	<a href="#">JA88.1</a>
		<a href="#">JB00</a> .- Preterm labour or delivery	<a href="#">JB00</a> .-
 <i>TUC is</i>		with mention of:	code to:
<a href="#">JA65.7</a> Subluxation of symphysis pubis in pregnancy, childbirth or the puerperium		<a href="#">JB04 - JB06</a> Obstructed labour due to malposition or malpresentation of fetus, maternal pelvic abnormality or due to other causes	<a href="#">JB04 - JB06</a>

<i>TUC is</i>	when reported as the cause of:	code to:
<a href="#">JA67.4</a> Spinal and epidural anaesthesia-induced headache during pregnancy	<a href="#">JA67.2</a> Central nervous system complications of anaesthesia during pregnancy	<a href="#">JA67.2</a>

<i>TUC is</i>	with mention of:	code to:
<a href="#">JA80</a> .- Maternal care related to multiple gestation	<a href="#">JB04</a> - <a href="#">JB06</a> Obstructed labour due to malposition or malpresentation of foetus, maternal pelvic abnormality, or other causes	<a href="#">JB04</a> - <a href="#">JB06</a>
<a href="#">JA81</a> .- Maternal care related to complications specific to multiple gestation	<a href="#">JB0D.3</a> Other complications of obstetric surgery or procedures	<a href="#">JB0D.3</a>
	<a href="#">JB42.1</a> Amniotic fluid embolism	<a href="#">JB42.1</a>

<i>TUC is</i>	when reported as the cause of:	code to:
<a href="#">JA82</a> .- Maternal care for known or suspected malpresentation of fetus	<a href="#">JA43</a> .- Postpartum haemorrhage	<a href="#">JA43</a> .-
<a href="#">JA83</a> .- Maternal care for known or suspected disproportion	<a href="#">JB04</a> - <a href="#">JB06</a> Obstructed labour due to malposition or malpresentation of foetus, maternal pelvic abnormality, or other causes	<a href="#">JB04</a> - <a href="#">JB06</a>
<a href="#">JA84</a> .- Maternal care for known or suspected abnormality of pelvic organs	<a href="#">JB09</a> - <a href="#">JB0A</a> Perineal laceration during delivery and other obstetric trauma	<a href="#">JB09</a> - <a href="#">JB0A</a>
<a href="#">JA85</a> .- Maternal care for known or suspected fetal abnormality or damage	<a href="#">JB0D</a> .- Certain specified complications of labour or delivery, not elsewhere classified	<a href="#">JB0D</a> .-
<a href="#">JA86</a> .- Maternal care for other known or suspected fetal problems	<a href="#">JB40</a> .- Infections in the puerperium	<a href="#">JB40</a>

<i>TUC is</i>	with mention of:	code to:
<a href="#">JA82</a> .- Maternal care for known or suspected malpresentation of fetus	<a href="#">JA83</a> .- Maternal care for known or suspected disproportion	<a href="#">JA83</a> .-

<i>TUC is</i>	with mention of:	code to:
<a href="#">JA83.Z</a> Maternal care for known or suspected disproportion, unspecified	<a href="#">JA83.0</a> Maternal care for disproportion due to deformity of maternal pelvic bones	<a href="#">JA83.0</a>
	<a href="#">JA83.1</a> Maternal care for disproportion due to generally contracted pelvis	<a href="#">JA83.1</a>
	JA83.2 Maternal care for disproportion due to inlet contraction of pelvis	<a href="#">JA83.2</a>
	<a href="#">JA83.3</a> Maternal care for disproportion due to outlet contraction of pelvis	<a href="#">JA83.3</a>

<i>TUC is</i>	when reported as the cause of:	code to:
<a href="#">JA87.-</a> Maternal care related to polyhydramnios	<a href="#">JA8C.-</a> Maternal care related to premature separation of placenta	<a href="#">JA8C.-</a>
	<a href="#">JB03.-</a> Long labour	<a href="#">JB03.-</a>
	<a href="#">JB04 - JB06</a> Obstructed labour due to malposition or malpresentation of foetus, maternal pelvic abnormality, or other causes	<a href="#">JB04 - JB06</a>
	<a href="#">JA43.-</a> Postpartum haemorrhage	<a href="#">JA43.-</a>
	<a href="#">JB0D.-</a> Certain specified complications of labour or delivery, not elsewhere classified	<a href="#">JB0D.-</a>
	<a href="#">JB40.-</a> Infections in the puerperium	<a href="#">JB40.-</a>
	<a href="#">JB42.1</a> Amniotic fluid embolism	<a href="#">JB42.1</a>

<i>TUC is</i>	when reported as the cause of:	code to:
<a href="#">JA88.0</a> Oligohydramnios	<a href="#">JA43.-</a> Postpartum haemorrhage	<a href="#">JA43.-</a>
<a href="#">JA88.Y</a> Other specified disorders of amniotic fluid and membranes	<a href="#">JA88.1</a> Infection of amniotic sac or membranes	<a href="#">JA88.1</a>
<a href="#">JA88.Z</a> Disorders of amniotic fluid and membranes, unspecified	<a href="#">JB03.-</a> Long labour	<a href="#">JB03.-</a>
	<a href="#">JB40.-</a> Infections in the puerperium	<a href="#">JB40.-</a>
	<a href="#">JB0D.-</a> Certain specified complications of labour or delivery, not elsewhere classified	<a href="#">JB0D.-</a>

<i>TUC is</i>	with mention of:	code to:
<a href="#">JA89.3</a> Premature rupture of membranes	<a href="#">JA88.1</a> Infection of amniotic sac or membranes	JA88.1
	<a href="#">JB03</a> .- Long labour	<a href="#">JB03</a> .-
	<a href="#">JA43</a> .- Postpartum haemorrhage	<a href="#">JA43</a> .-
	<a href="#">JB0D</a> .- Certain specified complications of labour or delivery, not elsewhere classified	<a href="#">JB0D</a> .-
	<a href="#">JB40</a> .- Infections in the puerperium	<a href="#">JB40</a> .-
	<a href="#">JB42.1</a> Amniotic fluid embolism	<a href="#">JB42.1</a>

<i>TUC is</i>	when reported as the cause of:	code to:
<a href="#">JA8A.0</a> Placental transfusion syndromes	<a href="#">JA8C</a> .- Maternal care related to premature separation of placenta	<a href="#">JA8C</a> .-
<a href="#">JA8A.1</a> Malformation of placenta	<a href="#">JA42</a> .- Intrapartum haemorrhage	<a href="#">JA42</a> .-
<a href="#">JA8A.Y</a> Other specified maternal care related to placental disorders	<a href="#">JA43</a> .- Postpartum haemorrhage	<a href="#">JA43</a> .-
<a href="#">JA8A.Z</a> Maternal care related to placental disorders, unspecified	<a href="#">JB0D</a> .- Certain specified complications of labour or delivery, not elsewhere classified	<a href="#">JB0D</a> .-
	<a href="#">JB40</a> .- Infections in the puerperium	<a href="#">JB40</a> .-

<i>TUC is</i>	when reported as the cause of:	code to:
<a href="#">JA8A.2</a> Morbidly adherent placenta	<a href="#">JA8B.1</a> Placenta praevia with haemorrhage	<a href="#">JA8B.1</a>
	<a href="#">JA8B.0</a> Placenta praevia specified as without haemorrhage	<a href="#">JA8B.0</a>
	<a href="#">JA8B.Z</a> Maternal care related to placenta praevia or low lying placenta, unspecified	<a href="#">JA8B.Z</a>

<i>TUC is</i>	when reported as the cause of:	code to:
<a href="#">JA8E</a> Maternal care related to prolonged pregnancy	<a href="#">JB0D</a> .- Certain specified complications of labour or delivery, not elsewhere classified	<a href="#">JB0D</a> .-

<i>TUC is</i>	when reported as the cause of:	code to:
<a href="#">JB00</a> .- Preterm labour or delivery	<a href="#">JA8C</a> .- Maternal care related to premature separation of placenta	<a href="#">JA8C</a> .-
<a href="#">JB01</a> .- Failed induction of labour	<a href="#">JA42</a> .- Intrapartum haemorrhage	<a href="#">JA42</a> .-
<a href="#">JB02</a> .- Abnormalities of forces of labour	<a href="#">JA43</a> .- Postpartum haemorrhage	<a href="#">JA43</a> .-
<a href="#">JB03</a> .- Long labour	<a href="#">JB04</a> - <a href="#">JB06</a> Obstructed labour due to malposition or malpresentation of foetus, maternal pelvic abnormality, or other causes	<a href="#">JB04</a> - <a href="#">JB06</a>
<a href="#">JB07</a> .- Labour or delivery complicated by foetal distress	<a href="#">JB0D</a> .- Certain specified complications of labour or delivery, not elsewhere classified	<a href="#">JB0D</a> .-
<a href="#">JB08</a> .- Labour or delivery complicated by umbilical cord complications	<a href="#">JB40</a> .- Infections in the puerperium	<a href="#">JB40</a> .-

<i>TUC is</i>	with mention of:	code to:
<a href="#">JB04</a> .- Obstructed labour due to malposition or malpresentation of fetus	<a href="#">JB05</a> .- Obstructed labour due to maternal pelvic abnormality	<a href="#">JB05</a> .-

<i>TUC is</i>	when reported as the cause of:	code to:
<a href="#">JB09.2</a> , <a href="#">JB09.3</a> , <a href="#">JB09.Z</a> Third, fourth or unspecified degree perineal laceration during delivery	<a href="#">JA43</a> .- Postpartum haemorrhage	<a href="#">JA43</a> .-
	<a href="#">JB40</a> .- Infections in the puerperium	<a href="#">JB40</a> .-

<i>TUC is</i>	when reported as the cause of:	code to:
<a href="#">JB0C.5</a> Spinal and epidural anaesthesia-induced headache during labour and delivery	<a href="#">JB0C.3</a> Central nervous system complications of anaesthesia during labour or delivery	<a href="#">JB0C.3</a>

*TUC is* when reported as the cause of: code to:

[JB0D.0](#) Maternal distress during labour and delivery [JA43](#) Postpartum haemorrhage [JA43](#)

[JB0D.1](#) Shock during or following labour and delivery [JB40](#) Infections in the puerperium [JB40](#)

*TUC is* when reported as the cause of: code to:

[JB0D.2](#) Pyrexia during labour, not elsewhere classified [JB40](#) Infections in the puerperium [JB40](#)

*TUC is* when reported as the cause of: code to:

[JB0D.4](#) Delayed delivery after artificial rupture of membranes [JB0D.4](#) Delayed delivery after artificial rupture of membranes [JA43.-](#)

[JB0D.5](#) Delayed delivery after spontaneous or unspecified rupture of membranes [JB0D.-](#) Certain specified complications of labour or delivery, not elsewhere classified [JB0D.-](#)

[JB40.-](#) Infections in the puerperium [JB40.-](#)

*TUC is* when reported as the cause of: code to:

[JB0D.6](#) Vaginal delivery following previous caesarean section [JA8A.2](#) Morbidly adherent placenta [JA8A.2](#)

[JB0A.1](#) Rupture of uterus during labour [JB0A.1](#)

[JB0A.2](#) Postpartum inversion of uterus [JB0A.2](#)

[JA43.-](#) Postpartum haemorrhage [JA43.-](#)

[JB0D.-](#) Certain specified complications of labour or delivery, not elsewhere classified [JB0D.-](#)

[JB40.-](#) Infections in the puerperium [JB40.-](#)



<i>TUC is</i>	when reported as the cause of:	code to:
<a href="#">JB41.0</a> Superficial thrombophlebitis in the puerperium	<a href="#">JB42.2</a> Obstetric blood-clot embolism	<a href="#">JB42.2</a>
<a href="#">JB41.2</a> Haemorrhoids in the puerperium		
<a href="#">JB41.Y</a> Other venous complications in the puerperium		
<a href="#">JB41.Z</a> Venous complication in the puerperium, unspecified		

<i>TUC is</i>	when reported as the cause of:	code to:
<a href="#">JB43.3</a> Spinal and epidural anaesthesia-induced headache during the puerperium	<a href="#">JB43.2</a> Central nervous system complications of anaesthesia during the puerperium	<a href="#">JB43.2</a>

**M1 - Conditions of maternal mortality not to be used as UCOD (See Section [2.19.3.24](#) for details)**

**TUC is:**

<a href="#">JA05</a> .- Complications following abortion, ectopic or molar pregnancy	<b>Code to:</b> Abortive outcome of pregnancy of JA00-JA04
--	--

**TUC is:**

<a href="#">JB65</a> Sequelae of complication of pregnancy, childbirth or the puerperium	<b>Code to:</b> <a href="#">JB62</a> .- Death from sequelae of obstetric causes
--	---

**M1 - Conditions of maternal mortality not to be used as UCOD under certain condition (See Section [2.18.1](#) and [2.19.3.18](#))**

**TUC is:**

<a href="#">JA80</a> Maternal care related to multiple gestation	<p><b>Not to be used for the underlying cause of death, if a more specific complication is reported.</b></p> <p><b>Code to:</b> the more specific complication.</p> <p>If there is no specific complication, <b>code to</b> <a href="#">JB0Z</a> Complications of labor or delivery, unspecified</p>
--	--

**TUC is:**

[JB20](#) - [JB2Z](#)  
Delivery

**Not to be used for the underlying cause of death, if a more specific complication is reported.**

**Code to:** code to the more specific complication of [JB0C](#).- to [JB0D](#).- or [JB0Y](#). If no complication is reported **code to** [JB0Z](#).

Example 11

- 1 (a) Subarachnoid haemorrhage 9 days [8B01.2](#)
  - (b) Eclampsia during pregnancy 10 days [JA25.0](#)
  - (c) Severe pre-eclampsia 11 days [JA24.1](#)
  - (d)
- 2

The deceased was pregnant: Yes, at the time of death; Pregnancy contributed to death: Yes

Severe pre-eclampsia is the tentative underlying cause according to Step SP3. There is a special instruction on 'Pre-eclampsia' reported with mention of 'eclampsia'. Apply this instruction and select [JA25.0](#) as the tentative underlying cause. As no other special instructions apply, and the death was within 42 days after the obstetric cause, [JA25.0](#) is the underlying cause of death.

#### **M2 - Specificity (See Section [2.18.2](#))**

Example 12

- 1 (a) Heart failure 1 day [BD1Z](#)
  - (b) Hypovolemic shock 2 days [MG40.1](#)
  - (c) Fourth degree perineal laceration 2 days [JB09.3](#)
  - (d) Perineal laceration during delivery 2 days [JB09.Z](#)
- 2

The deceased was pregnant: Yes, within 42 days of death; Pregnancy contributed to death: Yes

Perineal laceration during delivery ([JB09.Z](#)) is the tentative starting point by Step SP3. However, there is a category that provides more precise information about this condition which is fourth degree perineal laceration ([JB09.3](#)). Apply Step M2 and select [JB09.3](#) as the underlying cause of death.

#### **M4 - Special instructions on surgery and other medical procedures (See Section [2.18.4](#) and [2.19.4](#))**

### Example 13

- 1 (a) Postoperative haemorrhage [NE81.0Z](#)  
(b) Caesarean section [JB22.Z](#)  
(c)  
(d)

2

The deceased was pregnant: Yes, at the time of death; Pregnancy contributed to death: Yes  
Reason for surgery: Prolonged labour

Caesarean section [JB22.Z](#) is the tentative by Step SP3. And the reason why the caesarean section was performed was stated as prolonged labour. Code [JB03.Z](#) Long labour, unspecified as the underlying cause of death.

### Example 14

- 1 (a) Septic shock 1 day [1G41](#)  
(b) Postpartum cardiomyopathy 1 month [JB44.3](#)  
(c) Emergency caesarean section 1 month [JB22.1](#)  
(d)

2

The deceased was pregnant: Yes, within 42 days of death; Pregnancy contributed to death: Yes

Emergency caesarean section [JB22.1](#) is the tentative underlying cause by Step SP3. The reason for caesarean section is not reported but the complication is. Code the complication, postpartum cardiomyopathy [JB44.3](#) as the underlying cause of death.

### **M4 – Special instructions on maternal mortality (See Section [2.19.7](#))**

Terms used here in the instruction is as follows:

- Certain maternal diseases: [JA00.-](#) to [JB4Z](#), [JB60](#), [JB6Y](#), 1C14
- Maternal diseases classified elsewhere: [JB63](#) (infections), [JB64](#) (other)
- Injury or external causes: Chapter 22 or Chapter 23
- Other conditions: other than above

Maternal diseases - If the tentative underlying cause (TUC) is 'certain maternal diseases' and the deceased was pregnant at the time of death, within 42 days before death, or the duration is unknown or unstated, keep the TUC. - If the TUC is 'maternal diseases classified elsewhere' keep the TUC and postcoordinate the code for the specific disease classified elsewhere from Chapter 01-19. - If the TUC is [JB61.0](#), [JB61.Z](#), [JB62.0](#) or [JB62.Z](#), keep it and its post-coordinated code, if any, as the TUC. - If the TUC is 'certain maternal diseases' or maternal diseases classified elsewhere' but the deceased was pregnant in more than 42 days but less than one year before death, then code to [JB61.-](#) as the TUC and add the code for the specific maternal disease to the cluster.

Other conditions or indirect obstetric causes - If the TUC is [JB61.1](#) or [JB62.1](#), keep it and its post-coordinated code if any as the TUC. - If the TUC is 'other conditions', and the pregnancy contributed to death, and the deceased was pregnant at the time of death, within 42 days before death, or the duration is unknown or unstated, code to [JB63](#).- or [JB64](#).- as appropriate and add the specific 'other condition' to the cluster. - If the TUC is 'other conditions', and the pregnancy did not contribute to death, but the deceased was pregnant at the time of death, within 42 days before death, keep the TUC and add [XT0S](#) Pregnancy to the cluster. - If the TUC is 'other conditions', and the pregnancy did not contribute to death, and the deceased was pregnant in more than 42 days before death, or the duration is unknown or unstated, keep the TUC.

See 'Determining whether pregnancy contributed to death' in section 2.21.8.2 to decide whether pregnancy contributed to death from the information on the death certificate.

Injury or external causes - If the TUC is 'injury or external cause', and the deceased was pregnant at the time of death, within 42 days before death, keep the TUC and add XT03 Pregnancy to the cluster. - If the TUC is 'injury or external cause', and the deceased was pregnant in more than 42 days before death, or the duration is unknown or unstated, keep the TUC.

#### 3.14.14 Target list of causes of death for verbal autopsy

The use of this list is two-fold. For computer-coding VA (CCVA) algorithms that assign broad text labels for causes of death, this list could serve as a coding list, such that the CCVA program could directly code the death to one of these labels, and this table provides the related ICD-11 codes. Alternatively, this list could serve as a tabulation list for other VA cause of death assignment methods such as physician coding or expert algorithms, which have the potential to directly assign specific text labels for causes of death with their individual ICD-11 codes. In such situations, the detailed coded data from these methods could then be aggregated for tabulation according to the code groups, to enable comparison with computer derived diagnosis. In other situations, the specifically ICD-11 coded data from physician coded VA or expert algorithms could be aggregated and analysed using other tabulation lists such as the WHO Mortality Lists or the Global Health Estimates/Global Burden of Disease categories. In all situations, coded data from VA should be specifically labelled according to the data source and the type of coding approach used, and separately tabulated for each data source/coding method. Column 1 contains the code for the verbal autopsy entity. Column 2 lists the related titles hyperlinked to the ICD-11 codes that would be used if the condition labelled by column 2 were coded to ICD-11.

Verbal autopsy code	Verbal autopsy title
<b>VAs-01 Infectious and parasitic diseases</b>	
VAs-01.01	<a href="#"><u>Sepsis</u></a>
VAs-01.02	<a href="#"><u>Acute respiratory infection, including pneumonia</u></a>
VAs-01.03	<a href="#"><u>HIV/AIDS related death</u></a>
VAs-01.04	<a href="#"><u>Diarrheal diseases</u></a>
VAs-01.05	<a href="#"><u>Malaria</u></a>
VAs-01.06	<a href="#"><u>Measles</u></a>
VAs-01.07	<a href="#"><u>Meningitis and encephalitis</u></a>
VAs-01.08	<a href="#"><u>Tetanus</u></a>
VAs-01.09	<a href="#"><u>Pulmonary tuberculosis</u></a>
VAs-01.10	<a href="#"><u>Pertussis</u></a>
VAs-01.11	<a href="#"><u>Haemorrhagic fever</u></a>
VAs-01.12	<a href="#"><u>Dengue fever</u></a>
VAs-01.13	<a href="#"><u>Coronavirus disease (COVID-19)</u></a>
VAs-01.99	<a href="#"><u>Unspecified infectious disease</u></a>
<b>Non-communicable diseases</b>	
VAs-98	<a href="#"><u>Other and unspecified non-communicable disease</u></a>
<b>VAs-02 Neoplasms</b>	
VAs-02.01	<a href="#"><u>Oral neoplasms</u></a>
VAs-02.02	<a href="#"><u>Digestive neoplasms</u></a>
VAs-02.03	<a href="#"><u>Respiratory neoplasms</u></a>
VAs-02.04	<a href="#"><u>Breast neoplasms</u></a>
VAs-02.05	<a href="#"><u>Female reproductive neoplasms</u></a>
VAs-02.06	<a href="#"><u>Male reproductive neoplasms</u></a>
VAs-02.99	<a href="#"><u>Other and unspecified neoplasms</u></a>
<b>VAs-03 Nutritional and endocrine disorders</b>	
VAs-03.01	<a href="#"><u>Severe anaemia</u></a>
VAs-03.02	<a href="#"><u>Severe malnutrition</u></a>
VAs-03.03	<a href="#"><u>Diabetes mellitus</u></a>
<b>VAs-04 Diseases of the circulatory system</b>	
VAs-04.01	<a href="#"><u>Acute cardiac disease</u></a>
VAs-04.02	<a href="#"><u>Stroke</u></a>
VAs-04.03	<a href="#"><u>Sickle cell with crisis</u></a>
VAs-04.99	<a href="#"><u>Other and unspecified cardiac disease</u></a>
<b>VAs-05 Respiratory disorders</b>	

Verbal autopsy code	Verbal autopsy title
VAs-05.01	<a href="#">Chronic obstructive pulmonary disease (COPD)</a>
VAs-05.02	<a href="#">Asthma</a>
<b>VAs-06 Gastrointestinal disorders</b>	
VAs-06.01	<a href="#">Acute abdomen</a>
VAs-06.02	<a href="#">Liver cirrhosis</a>
<b>VAs-07 Renal disorders</b>	
VAs-07.01	<a href="#">Renal failure</a>
<b>VAs-08 Mental and nervous system disorders</b>	
VAs-08.01	<a href="#">Epilepsy</a>
<b>VAs-09 Pregnancy childbirth and puerperium-related disorders</b>	
VAs-09.01	<a href="#">Ectopic pregnancy</a>
VAs-09.02	<a href="#">Abortion-related death</a>
VAs-09.03	<a href="#">Pregnancy-induced hypertension</a>
VAs-09.04	<a href="#">Obstetric haemorrhage</a>
VAs-09.05	<a href="#">Obstructed labour</a>
VAs-09.06	<a href="#">Pregnancy-related sepsis</a>
VAs-09.07	<a href="#">Anaemia of pregnancy</a>
VAs-09.08	<a href="#">Ruptured uterus</a>
VAs-09.99	<a href="#">Other and unspecified maternal cause</a>
<b>VAs-10 Neonatal causes of death</b>	
VAs-10.01	<a href="#">Prematurity or low birth weight</a>
VAs-10.02	<a href="#">Birth asphyxia</a>
VAs-10.03	<a href="#">Neonatal pneumonia</a>
VAs-10.04	<a href="#">Neonatal sepsis</a>
VAs-10.05	<a href="#">Neonatal tetanus</a>
VAs-10.06	<a href="#">Congenital malformation</a>
VAs-10.99	<a href="#">Other and unspecified perinatal cause of death</a>
<b>VAs-11 Stillbirths</b>	
VAs-11.01	<a href="#">Fresh stillbirth</a>
VAs-11.02	<a href="#">Macerated stillbirth</a>
<b>VAs-12 External causes of death</b>	
VAs-12.01	<a href="#">Road traffic accident</a>
VAs-12.02	<a href="#">Other transport accident</a>
VAs-12.03	<a href="#">Accidental fall</a>

Verbal autopsy code	Verbal autopsy title
VAs-12.04	<a href="#"><u>Accidental drowning and submersion</u></a>
VAs-12.05	<a href="#"><u>Accidental exposure to smoke, fire and flames</u></a>
VAs-12.06	<a href="#"><u>Contact with venomous animals and plants</u></a>
VAs-12.07	<a href="#"><u>Accidental poisoning and exposure to noxious substance</u></a>
VAs-12.08	<a href="#"><u>Intentional self-harm</u></a>
VAs-12.09	<a href="#"><u>Assault</u></a>
VAs-12.10	<a href="#"><u>Exposure to force of nature</u></a>
VAs-12.99	<a href="#"><u>Other and unspecified external cause of death</u></a>
VAs-99	<a href="#"><u>Cause of death unknown</u></a>

### 3.15 Annex D: Differences between ICD-10 and ICD-11

#### 3.15.1 Chapter 01 – Differences between ICD–10 and ICD–11 in Chapter 01

The chapter includes more infectious items than in the past. Also, influenza has been moved from the respiratory to the infectious diseases chapter. Tuberculosis, leprosy have been grouped under ‘Mycobacterial diseases’, because identification, course, and treatment are similar. Prion diseases have been moved to the Nervous system.

#### **Table 1: Comparison of ICD-10 block structure with ICD-11 equivalent structure**

ICD-10 block heading	ICD-11 equivalent structure
A00-A09 Intestinal infectious diseases	Gastroenteritis or colitis of infectious origin
A15-A19 Tuberculosis	Part of the grouping - Mycobacterial diseases
A20-28 Certain zoonotic bacterial diseases	Certain zoonotic bacterial diseases
A30-A49 Other bacterial diseases	Other bacterial diseases
A50-A64 Infections with a predominantly sexual mode of transmission	Predominantly sexually transmitted infections
A65-A69 Other spirochaetal diseases	Part of the grouping - Other specified bacterial diseases
A70-A74 Other diseases caused by chlamydiae	Part of the grouping – Other bacterial diseases
A75-A79 Rickettsioses	Part of the grouping – Other bacterial diseases
A80-A89 Viral infections of the central nervous system	Viral infections of the central nervous system
A92-A99 Arthropod-borne viral fevers and viral haemorrhagic fevers	Split into two groups - Other arthropod-borne viral fevers and Certain zoonotic viral diseases
B00-B09 Viral infections characterized by skin and mucous membrane lesions	Viral infections characterised by skin or mucous membrane lesions
B15-B19 Viral hepatitis	Viral hepatitis
B20-B24 Human immunodeficiency virus [HIV] disease	Human immunodeficiency virus disease
B25-B34 Other viral diseases	Certain other viral diseases
B35-B49 Mycoses	Mycoses
B50-B64 Protozoal diseases	Part of the grouping - Parasitic diseases
B65-B83 Helminthiases	Part of the grouping - Parasitic diseases
B85-B89 Pediculosis, acariasis and other infestations	Part of the grouping - Parasitic diseases
B90-B94 Sequelae of infectious and parasitic diseases	Sequelae of infectious diseases
B95-B98 Bacterial, viral and other infectious agents	Now part of extension codes for organisms
B99-B99 Other infectious diseases	Certain other disorders of infectious origin

### 3.15.2 Differences between ICD–10 and ICD–11 in Chapter 02

The most significant change to the hierarchy of Chapter 02 is the inclusion of certain morphology types within the chapter (previously found in ICD–10, Appendix A). There are now precoordinated codes consisting of both morphology and site. Other types of morphology and greater site specificity not included in Chapter 02 are found in the Chapter X, Extension codes, and can be used for postcoordination.



Other changes include: grouping together all neoplasms of brain and central nervous system regardless of behaviour; grouping together all haematopoietic and lymphoid tissues; and the addition of the new group Malignant mesenchymal neoplasms. The previous ICD–10 group Neoplasms of uncertain or unknown behaviour has been split into two separate groups - Neoplasms of uncertain behaviour and Neoplasms of unknown behaviour.

**Table 1: Comparison of ICD-10 block structure with ICD-11 equivalent structure**

<b>ICD-10 block heading</b>	<b>ICD-11 equivalent structure</b>
C00-C97 Malignant neoplasms	Neoplasms of brain or central nervous system  Neoplasms of haematopoietic or lymphoid tissues Malignant neoplasms, except of lymphoid, haematopoietic, central nervous system or related tissues
D00-D09 In situ neoplasms	In situ neoplasms, except of lymphoid, haematopoietic, central nervous system or related tissues
D10-D36 Benign neoplasms	Benign neoplasms, except of lymphoid, haematopoietic, central nervous system or related tissues
D37-D48 Neoplasms of uncertain or unknown behaviour	Neoplasms of uncertain behaviour, except of lymphoid, haematopoietic, central nervous system or related tissues  Neoplasms of unknown behaviour, except of lymphoid, haematopoietic, central nervous system or related tissues

### 3.15.3 Differences between ICD–10 and ICD–11 in Chapter 03

ICD–10, Chapter 03 Disease of the blood and blood-forming organs and certain disorders involving the immune mechanism has been split into two chapters: one for diseases of blood or blood-forming organs (Ch. 03) and the other for disorders of the immune system (Ch. 04). In ICD-10 there were five major sections for blood disorders which have now been reclassified into three sections in ICD-11.

A broad grouping Anaemias and other erythrocyte disorders now contains, Nutritional anaemias, Haemolytic anaemias and Aplastic and other anaemias with subdivisions for acquired and congenital.

**Table 1: Comparison of ICD-10 block structure with ICD-11 equivalent structure**

<b>ICD-10 block heading</b>	<b>ICD-11 equivalent structure</b>
D50-D53 Nutritional anaemias	Part of the grouping - Anaemias and other erythrocyte disorders
D55-D59 Haemolytic anaemias	Part of the grouping - Anaemias and other erythrocyte disorders
D60-D64 Aplastic and other anaemias	Part of the grouping - Anaemias and other erythrocyte disorders
D65-D69 Coagulation defects, purpura and other haemorrhagic conditions	Coagulation defects, purpura and other haemorrhagic and related conditions
D70-D77 Other diseases of blood and blood-forming organs	Concepts redistributed to one of the following groupings: Anaemias and other erythrocyte disorders Coagulation defects, purpura and other haemorrhagic and related conditions or Diseases of spleen
D80-D89 Certain disorders involving the immune mechanism	Move to Chapter 04 'Diseases of the immune system'

#### 3.15.4 Differences between ICD-10 and ICD-11 in Chapter 04

ICD-10, Chapter 03 'Diseases of the blood and blood-forming organs and certain disorders involving the immune mechanism' has been split into two chapters: one for diseases of blood or blood-forming organs (Ch. 03) and the other for disorders of the immune system (Ch. 04). This new chapter (Ch. 04) was created to better capture the complexity of the disease processes of the immune system.

**Table 1: Comparison of ICD-10 block structure with ICD-11 equivalent structure**

<b>ICD-10 block heading</b>	<b>ICD-11 equivalent structure</b>
D80-D89 Certain disorders involving the immune mechanism	<ul style="list-style-type: none"> <li>Primary immunodeficiencies</li> <li>Acquired immunodeficiencies</li> <li>Autoinflammatory disorders</li> <li>Allergic or hypersensitivity conditions</li> <li>Immune system disorders involving white cell lineages</li> <li>Certain disorders involving the immune system</li> <li>Diseases of thymus</li> </ul>

#### 3.15.5 Differences between ICD-10 and ICD-11 in Chapter 05

Changes and additions have been made to Diabetes mellitus with the inclusion of categories for Intermediate hyperglycaemia (including Impaired glucose regulation) and Insulin-resistance syndromes. Nutritional disorders section incorporates current terminology and contains a detailed classification for vitamin and mineral deficiencies as well as for obesity.

The Metabolic disorders section also includes more detail and the organisation of the various types of metabolic disorders has been improved.

**Table 1:** *Comparison of ICD-10 block structure with ICD-11 equivalent structure in Chapter 5*

<b>ICD-10 block heading</b>	<b>ICD-11 equivalent structure</b>
E00-E07 Disorders of thyroid gland	Disorders of the thyroid gland or thyroid hormones system. The structure for this section has not changed but has been revised to better reflect current disease processes.
E10-E14 Diabetes mellitus	Diabetes mellitus (Specifies the 'type' of diabetes mellitus i.e. Type 1, Type 2, other and unspecified. 'Diabetic' complications are primarily parented to their respective body system chapter).
E15-E16 Other disorders of glucose regulation and pancreatic internal secretion	Other disorders of glucose regulation or pancreatic internal secretion – has remained unchanged.
E20-E35 Disorders of other endocrine glands	This block has been unbundled and the sections renamed to better reflect the conditions classified within each entity: Disorders of the parathyroid and parathyroid hormone system Disorders of the pituitary hormone system Disorders of the adrenal glands and adrenal hormone system Disorders of the gonadal hormone system Certain disorders of puberty Polyglandular dysfunction Disorders of lipoprotein metabolism and certain specified lipidaemias
E40-E46 Malnutrition	Undernutrition - Two new subsections have been added for Undernutrition based on anthropometric or clinical criteria and Undernutrition due to specific nutrient deficiencies
E50-E64 Other nutritional deficiencies	Part of the grouping - Undernutrition
E65-E68 Obesity and other hyperalimentation	Overweight, obesity or specific nutrient excesses
E70-E90 Metabolic disorders	Metabolic disorders with subsections based on aetiology

### 3.15.6 Differences between ICD-10 and ICD-11 in Chapter 06

Changes to this chapter include restructuring of the hierarchy, the inclusion of more current terminology, and specific groupings for single episodes of harmful use, harmful pattern of use, dependence, intoxication, and withdrawal by substance type.

In the ICD-10, the numbers of large groupings, or 'blocks', of disorders was artificially constrained by the decimal coding system used in the classification, such that it was only possible to have a maximum of ten major groupings of disorders within the mental and

behavioural disorder chapter (corresponding to the digits 0 to 9). This meant that some groupings were created that were not based on clinical utility or scientific evidence. In the ICD–10, for example, one block (F30-F39) is devoted to Mood (affective) disorders, while Anxiety disorders represent only a portion of a broad and heterogeneous block (F40- F49) called ‘Neurotic, stress-related, and somatoform disorders’. Another block ? ‘Behavioural syndromes associated with physiological disturbances and physical factors’ ? unites disorders that are unrelated in terms of clinical symptoms and symptomatology except that they have something to do with the body.

Given the constrained structural parameters of the ICD–10, the developers of the classification provided a reasonable set of diagnostic groupings. However, the more flexible structural characteristics of ICD–11 make it possible to incorporate key features based on available scientific evidence and current practice for more optimal nosology.

**Table 1: Comparison of ICD-10 block structure with ICD-11 equivalent structure**

<b>ICD-10 block heading</b>	<b>ICD-11 equivalent structure</b>
F00-F09 Organic, including symptomatic, mental disorders	Neurocognitive disorders
F10-F19 Mental and behavioural disorders due to psychoactive substance use	Part of the grouping - Disorders due to substance use or addictive behaviours
F20-F29 Schizophrenia, schizotypal and delusional disorders	Schizophrenia or other primary psychotic disorders
F30-F39 Mood (affective) disorders	Mood disorders
F40-F48 Neurotic, stress-related and somatoform disorders	Anxiety or fear-related disorders
F50-F59 Behavioural syndromes associated with physiological disturbances and physical factors	Redistributed between Feeding or eating disorders, Mental or behavioural disorders associated with pregnancy, childbirth and the puerperium and new chapters for Sleep disorders and Sexual health
F60-F69 Disorders of adult personality and behaviour	Personality disorders and related traits
F70-F79 Mental retardation	Part of the grouping - Neurodevelopmental disorders
F80-F89 Disorders of psychological development	Part of the grouping - Neurodevelopmental disorders
F90-F98 Behavioural and emotional disorders with onset usually occurring in childhood and adolescence	Part of the grouping - Neurodevelopmental disorders
F99-F99 Unspecified mental disorder	Unspecified residual for the chapter

3.15.7 Chapter 07 is a new addition to ICD-11 and was not found in past editions

**Table 1: Comparison of ICD-10 block structure with ICD-11 equivalent structure**

ICD-10 previous location	ICD-11 equivalent structure
Codes from Mental Health and Nervous system chapters	Insomnia disorders
Concept not in ICD-10	Sleep-related movement disorders
Codes from Mental Health and Nervous system chapters	Hypersomnolence disorders
Codes from Neurology and Endocrine chapters	Sleep-related breathing disorders
Codes from Mental health chapter	Parasomnia disorders
Codes from Neurology chapter	Disorders of the sleep-wake schedule
Codes from Neurology chapter	Certain specified sleep disorders

### 3.15.8 Differences between ICD-10 and ICD-11 in Chapter 08

There has been a major restructuring and movement of previous ICD-10 concepts in this chapter. A number of new concepts have also been added. Cerebrovascular diseases have been moved to the Neurology chapter and multiply parented to the Circulatory chapter. Transient Ischaemic attack (TIA) is now also located under Cerebrovascular diseases and appears in Diseases of the nervous system.

ICD-11 sees a major overhaul in the organisation of the blocks which make up the neurology chapter. The restrictive decimal coding system of the ICD-10, with its capacity to contain only 11 blocks of disorders per chapter, resulted in blocks containing miscellaneous neurological entities which did not logically fit together, such as the episodic and paroxysmal disorders block, containing headache disorders, epilepsy, transient ischaemic attacks and sleep disorders. The ICD-11 now positions headache disorders, epilepsy and cerebrovascular disorders at block level, and sleep disorders at chapter level (Chapter 07).

Not only has the structure of the neurological chapter changed, but the approach to classification also integrates current clinical practice and advancements in the understanding of neurological diseases. In the time since the ICD-10 was published, enormous progress in the fields of genetics, molecular biology and medical technologies have been made. An increase in the number of codes is inevitable when one reflects on the recent knowledge gain in neurology, so a balance between comprehensiveness, clinical utility and maintaining a public health approach is the aim. The working groups tackled this issue by considering the more common disorders to appear in the chapter, with less common aetiological variations of these disorders being subject to a 'double coding' technique. One major change which illustrates the advancement of knowledge is the addition of a block entitled 'Paraneoplastic and autoimmune disorders of the nervous system'. This block contains immune-mediated neurological diseases, a field in which knowledge has exploded in recent years. A second example of how the new version reflects molecular biological advancement is through awarding Prion diseases block status despite their rarity. Previously, they featured as part of the infections of the central nervous system block, but research interest after the major public health issue in Europe in the 1990s has led to new variants of prion diseases being discovered.

**Table 1:** Comparison of ICD-10 block structure with ICD-11 equivalent structure

<b>ICD-10 block heading</b>	<b>ICD-11 equivalent structure</b>
G00-G09 Inflammatory diseases of the nervous system	This section is now located in Chapter 1 in a new block called Non-viral infections of the central nervous system
G10-G14 Systemic atrophies primarily affecting the central nervous system	Split between the Movement disorders and Motor neuron disease and related disorders
G20-G26 Extrapyrimalidal and movement disorders	Movement disorders
G30-G32 Other degenerative diseases of the nervous system	Neurocognitive disorders
G40-G47 Episodic and paroxysmal disorders	Epilepsy and seizures, Headache disorders and cerebrovascular blocks. Sleep disorders are now a stand-alone chapter (Ch. 07)
G50-G59 Nerve, nerve root and plexus disorders	Disorders of nerve root, plexus and peripheral nerves
G60-G64 Polyneuropathies and other disorders of the peripheral nervous system	Polyneuropathy, Mononeuropathy and Hereditary neuropathy
G70-G73 Diseases of myoneural junction and muscle	Diseases of neuromuscular junction and muscle
G80-G83 Cerebral palsy and other paralytic syndromes	Cerebral palsy
G90-G99 Other disorders of the nervous system	Other disorders of the nervous system - the following have been moved out to their own grouping: Diseases of the autonomic nervous system, Disorders of cerebrospinal fluid pressure and flow, Spinal cord disorders excluding trauma
A81 Atypical virus infections of central nervous system	Prion diseases

### 3.15.9 Differences between ICD-10 and ICD-11 in Chapter 09

There have been major changes to the structure and hierarchy of this chapter for ICD-11. The aetiology/manifestation convention (dagger/asterisk) of ICD-10 has not been kept in ICD-11.

**Table 1: Comparison of ICD-10 block structure with ICD-11 equivalent structure**



**ICD-10 block heading**

H00-H06 Disorders of eyelid, lacrimal system and orbit

H10-H13 Disorders of conjunctiva

H15-H22 Disorders of sclera, cornea, iris and ciliary body

H25-H28 Disorders of lens

H30-H36 Disorders of choroid and retina

H40-H42 Glaucoma

H43-H45 Disorders of vitreous body and globe

H46-H48 Disorders of optic nerve and visual pathway

H49-H52 Disorders of ocular muscles, binocular movement, accommodation and refraction

H53-H54 Visual disturbances and blindness

H55-H59 Other disorders of eye and adnexa

**ICD-11 equivalent structure**

Disorders of the ocular adnexa or orbit

Disorders of conjunctiva

Redistributed between the groupings Disorders of the eyeball – anterior segment and Disorders of the eyeball – posterior segment

Disorders of lens

Separate categories under Disorders of the eyeball – posterior segment

Glaucoma or glaucoma suspect

Redistributed between the groupings Disorders of the eyeball –posterior segment and Disorders of the eyeball affecting both anterior and posterior segments

Disorders of the visual pathways or centres

Redistributed between the groupings Strabismus or ocular motility and Disorders of refraction or accommodation

Visual impairment

Redistributed between the groupings Nystagmus and Postprocedural disorders of eye or ocular adnexa

### 3.15.10 Differences between ICD-10 and ICD-11 in Chapter 10

This chapter has retained a similar structure as in ICD-10, with only minor changes.

#### **Table 1: Comparison of ICD-10 block structure with ICD-11 equivalent structure**

<b>ICD-10 block heading</b>	<b>ICD-11 equivalent structure</b>
H60-H62 Diseases of external ear	Diseases of external ear
H65-H75 Diseases of middle ear and mastoid	Diseases of middle ear or mastoid
H80-H83 Diseases of inner ear	Diseases of inner ear
H90-H95 Other disorders of ear	Redistributed into the groupings Disorders with hearing impairment, Disorders of ear, not elsewhere classified and Postprocedural disorders of ear or mastoid process

### 3.15.11 Differences between ICD-10 and ICD-11 in Chapter 11

There has been some restructuring and regrouping throughout this chapter, with new concepts based on medical advancements over the last 20 years added. Medical terminology has been updated. The sections on Hypertension and Heart valve diseases have been expanded. Heart valve diseases have moved from a classification based on aetiology (rheumatic/non-rheumatic) followed by valve type and disease physiology; to a hierarchy led by valve type, then disease physiology, followed by aetiology, in keeping with current clinical practice. Non-rheumatic valve disease has therefore been moved from 'Other forms of heart disease' to the heart valve disease section. Acute rheumatic fever has been moved to Chapter 1.

Cerebrovascular diseases have been moved to the Neurology Chapter (08) as their primary parent with the Circulatory Chapter being a secondary parent.

**Table 1:** Comparison of ICD-10 block structure with ICD-11 equivalent structure in Chapter 11

<b>ICD-10 block heading</b>	<b>ICD-11 equivalent structure</b>
I00-I02 Acute rheumatic fever	Moved to Chapter 01 Infectious diseases
I05-I09 Chronic rheumatic heart diseases	Heart valve diseases - Change in hierarchy for the classification of heart valve disorders to heart valve type and then by aetiology
I10-I15 Hypertensive diseases	Hypertensive diseases - Remains relatively the same with expansion of some categories, essential hypertension now includes subcategories for diastolic/systolic hypertension
I20-I25 Ischaemic heart diseases	Ischaemic heart diseases - Change in terminology for AMI to reflect STEMI/NSTEMI only. Inclusion of timeframe for old AMI. Expansion of complications following and AMI. New section for 'Diseases of coronary artery' to include coronary atherosclerosis, coronary artery aneurysm, dissection, fistula
I26-I28 Pulmonary heart disease and diseases of pulmonary circulation	Pulmonary heart disease or diseases of pulmonary circulation - Expansion of some categories (e.g. pulmonary hypertension) to include new concepts, particularly pulmonary hypertension.
I30-I52 Other forms of heart disease	This block category title no longer exists in ICD-11 and the concepts within have been made distinct entities and expanded to include new terminology and disease processes
I60-I69 Cerebrovascular diseases	Reclassified to Chapter 08 Diseases of the nervous system
I70-I79 Diseases of arteries, arterioles and capillaries	Diseases of capillaries has been moved into Diseases of skin
I80-I89 Diseases of veins, lymphatic vessels and lymph nodes, not elsewhere classified	This section has been separated into two main blocks: Diseases of veins and Disorders of lymphatic vessels and lymph nodes. Oesophageal varices and Haemorrhoids have been reclassified to Chapter 13 Diseases of the digestive system - Vascular disorders of the oesophagus and Vascular disease of anus and anal canal, respectively
I95-I99 Other and unspecified disorders of the circulatory system	Marked expansion of the postprocedural disorders section with new codes for postprocedural disorders following repair of congenital anomalies.

### 3.15.12 Differences between ICD-10 and ICD-11 in Chapter 12

There has been some restructuring and regrouping of this chapter, with new concepts added and the inclusion of updated and current terminology.

- A new section, Inhalational, occupational and environmental lung disease has been added to improve the classification of respiratory disorders according to their aetiology.
- Sleep disorders of breathing and respiratory control have been moved into the new chapter of Sleep disorders (Chapter 7) and secondarily parented to the Respiratory Chapter.
- Cystic fibrosis has been moved to the Respiratory Chapter and multi-parented to Chapter 05 'Endocrine, nutritional or metabolic diseases'.

**Table 1:** Comparison of ICD-10 block structure with ICD-11 equivalent structure in Chapter 12

<b>ICD-10 block heading</b>	<b>ICD-11 equivalent structure</b>
J00-J06 Acute upper respiratory infections	Upper respiratory tract disorders section, Infectious diseases by infectious agent
J09-J18 Influenza and pneumonia	Lung infections
J20-J22 Other acute lower respiratory infections	Combined into the grouping - Lung infections
J30-J39 Other diseases of upper respiratory tract	Combined into the grouping - Upper respiratory tract disorders
J40-J47 Chronic lower respiratory diseases	Certain lower respiratory tract diseases
J60-J70 Lung diseases due to external agents	Lung diseases due to external agents
J80-J84 Other respiratory diseases principally affecting the interstitium	Respiratory diseases principally affecting the lung interstitium
J85-J86 Suppurative and necrotic conditions of lower respiratory tract	Combined into the grouping - Lung infections
J90-J94 Other diseases of pleura	Pleural, diaphragm and mediastinal disorders
J95-J99 Other diseases of the respiratory system	Certain diseases of the respiratory system Postprocedural respiratory disorders have been moved to a grouping of their own. Mediastinal and diaphragm disorders were moved to the section for Pleural, diaphragm and mediastinal disorders

### 3.15.13 Differences between ICD-10 and ICD-11 in Chapter 13

There has been a major restructuring and change of the previous ICD-10 concepts in this chapter. Detailed anatomical groups were added to the hierarchy, such as 'Diseases of duodenum', 'Diseases of the anal canal' or 'Diseases of the pancreas'. Independent categories for functional gastrointestinal disorders and inflammatory bowel diseases have

also been included to cover broad anatomical sites. Additional dimensions are available from the clinical findings section in Chapter 21 and Chapter X ‘Extension Codes’ for use in postcoordination. For example, with and without haemorrhage, with and without obstruction, with and without ascites, laterality and greater site specificity, etc.

Although ICD-10 included diseases of the oral cavity, salivary glands and jaws, the corresponding section of Chapter 13 in ICD-11 has been improved in structure and content to include diseases and disorders of the orofacial complex.

**Table 1: Comparison of ICD-10 block structure with ICD-11 equivalent structure**

<b>ICD-10 block heading</b>	<b>ICD-11 equivalent structure</b>
K00-K14 Diseases of oral cavity, salivary glands and jaws	Diseases or disorders of orofacial complex
K20-K31 Diseases of oesophagus, stomach and duodenum	Now in two groups – Diseases of oesophagus and Diseases of the stomach or the duodenum
K35-K38 Diseases of appendix	Diseases of appendix
K40-K46 Hernia	Hernia
K50-K52 Noninfective enteritis and colitis	Now in two groups – Gastritis, under Diseases of stomach and Certain noninfectious colitis or proctitis
K55-K64 Other diseases of intestines	Redistributed to various new groups based on anatomical sites
K65-K67 Diseases of peritoneum	Diseases of peritoneum
K70-K77 Diseases of liver	Diseases of liver
K80-K87 Disorders of gallbladder, biliary tract and pancreas	Now in two groups – Diseases of gallbladder or biliary tract and Diseases of pancreas
K90-K93 Other diseases of the digestive system	Redistributed to various groups including Postprocedural disorders of digestive system and Clinical findings in the digestive system

#### 3.15.14 Differences between ICD-10 and ICD-11 in Chapter 14

Chapter 14 has undergone major restructuring, with the addition of more detailed entities. The terminology has been updated to be more current. Detail has come from the fusion of the American, British and German dermatological terminologies.

**Table 1: Comparison of ICD-10 block structure with ICD-11 equivalent structure**

<b>ICD-10 block heading</b>	<b>ICD-11 equivalent structure</b>
L00-L08 Infections of the skin and subcutaneous tissue	Certain skin disorders attributable to infection or infestation
L10-L14 Bullous disorders	Renamed Immunobullous diseases of the skin and included under inflammatory dermatoses
L20-L30 Dermatitis and eczema	Dermatitis and eczema
L40-L45 Papulosquamous disorders	Papulosquamous dermatoses (included under inflammatory dermatoses)
L50-L54 Urticaria and erythema	Part of groupings – Urticaria, angioedema and other urticarial disorders and Inflammatory erythemas and other reactive inflammatory dermatoses
L55-L69 Radiation-related disorders of the skin and subcutaneous tissue	Dermatoses provoked by light or UV radiation
L60-L75 Disorders of skin appendages	Disorders of the epidermis and epidermal appendages
L80-L99 Other disorders of the skin and subcutaneous tissue	Redistributed to various groups throughout the restructured Skin chapter

### 3.15.15 Differences between ICD-10 and ICD-11 in Chapter 15

The blocks in this chapter have been reordered, and a new block - Auto-inflammatory syndromes has been added to the Immune Chapter and secondarily parented to here. The area of spinal conditions has been restructured and renamed to Conditions associated with the spine.

**Table 1: Comparison of ICD-10 block structure with ICD-11 equivalent structure**

<b>ICD-10 block heading</b>	<b>ICD-11 equivalent structure</b>
M00-M25 Arthropathies	Arthropathies
M30-M36 Systemic connective tissue disorders	Moved to Chapter 04 'Diseases of the immune system'
M40-M54 Dorsopathies	Conditions associated with the spine
M60-M79 Soft tissue disorders	Soft tissue disorders
M80-M94 Osteopathies and chondropathies	Osteopathies or chondropathies
M95-M99 Other disorders of the musculoskeletal and connective tissue	Redistributed to various groupings including Certain specified acquired deformities of musculoskeletal system or connective tissue, not elsewhere classified and Postprocedural musculoskeletal disorders, not elsewhere classified

### 3.15.16 Differences between ICD-10 and ICD-11 in Chapter 16

Chapter 16 has been reordered to distinguish diseases of the female genital system, the male genital system, and the urinary system. There is more specificity within the areas of Amenorrhea, Ovarian dysfunction, Female pelvic pain, Endometriosis, Adenomyosis, Female infertility, Male infertility, Early pregnancy loss, and Pregnancy outcomes reflecting current scientific understanding. The hierarchy is now divided into non-inflammatory disorders and inflammatory disorders, which are further divided by anatomical groupings. These groupings are in an order followed by gynaecological and obstetric examinations i.e. from external to internal genitalia. Neoplasms of the urinary system are primarily located in Chapter 02 'Neoplasms', Structural developmental anomalies of the urinary system are primarily located in Chapter 20 and Symptoms, signs or clinical findings involving the urinary system are primarily located in Chapter 21.

All diseases relating to the kidney are now classified under the main category for 'Diseases of the urinary system'. Acute kidney failure and chronic kidney disease now incorporates the currently used staging classification as proposed by [Kidney Disease | Improving Global Outcomes \(KDIGO\)](#).

The classification of Glomerular diseases has been restructured and is now divided into clinical features/syndromes. A new block has been added for Cystic and dysplastic kidney disease, originally, classified in ICD-10 to Chapter 17 'Congenital malformations, deformations and chromosomal abnormalities', with relevant entities grouped together and based on the 2015 KDIGO guidelines.

**Table 1: Comparison of ICD-10 block structure with ICD-11 equivalent structure**

<b>ICD-10 block heading</b>	<b>ICD-11 equivalent structure</b>
N00-N08 Glomerular diseases	Glomerular diseases - Classified to Diseases of the urinary system. This section is now classified according to clinical features or syndromes. Still includes: Nephritic syndrome Nephrotic syndrome Isolated proteinuria and albuminuria. The subdivisions describing morphology typically determined by biopsy have been moved to Chapter 21 under Clinical findings of the urinary system. Electron microscopy and immunofluorescence findings subdivisions have been removed from proteinuria with morphological lesion. This is now classified to Isolated proteinuria and albuminuria.
N10-N16 Renal-tubulo-interstitial diseases	Renal-tubulo-interstitial diseases - Classified to Diseases of the urinary system. Section remains relatively the same. Tubular and cortical necrosis has been unbundled from acute renal failure to be a distinct codable entity classified to this section.
N17-N19 Renal failure	Kidney failure - Classified to Diseases of the urinary system. Acute renal failure is no longer a bundled concept which previously identified the acute kidney damage i.e. acute tubular necrosis.
N20-N23 Urolithiasis	Urolithiasis - Classified to Diseases of the urinary system. Subdivided into upper urinary tract (includes kidney and ureter) and lower urinary tract (includes bladder and urethra). Renal colic has been reclassified to Chapter 21 Symptoms, signs and clinical findings involving the urinary system
N25-N29 Other disorders of kidney and ureter	Certain specified disorders of kidney or ureter - Classified to Diseases of the urinary system. Reclassification of disorders relating to the size of the kidney to Chapter 21 Symptoms, signs or clinical findings involving the urinary system - Macroscopic changes of size of the kidney
N30-N39 Other diseases of urinary system	Certain specified diseases of urinary system – remains similar to ICD-10
N40-N51 Diseases of male genital organs	Diseases of male genital organs– remains similar to ICD-10
N60-N64 Disorders of breast	Disorders of breast– remains similar to ICD-10
N70-N77 Inflammatory diseases of female pelvic organs	Inflammatory disorders of the female genital tract - Classified to Diseases of the female genital system.
N80-N98 Noninflammatory disorders of female genital tract	Noninflammatory disorders of female genital tract – Classified to Diseases of the female genital system



<b>ICD-10 block heading</b>	<b>ICD-11 equivalent structure</b>
N99 Other disorders of the genitourinary system	Other disorders of the genitourinary system – Postprocedural disorders of the genitourinary system has been moved out of this section to be a grouping of its own

3.15.17 Chapter 17 is a new addition to ICD–11 and was not found in past editions

**Table 1: Comparison of ICD-10 block structure with ICD-11 equivalent structure**

<b>ICD-10 previous location</b>	<b>ICD-11 equivalent structure</b>
Codes from Mental Health category F52 Sexual dysfunction, not caused by organic disorder or disease	Sexual dysfunctions
Codes from Mental Health category F52 Sexual dysfunction, not caused by organic disorder or disease and Genitourinary category N94 Pain and other conditions associated with female genital organs and menstrual cycle	Sexual pain disorders
Codes from Mental Health category F64 Gender identity disorders	Gender incongruence

### 3.15.18 Differences between ICD–10 and ICD–11 in Chapter 18

The chapter has been reordered but content remains similar to that in ICD–10. There have been some changes and additions made to the sections Maternal care related to the fetus and amniotic cavity and possible delivery problems and Complications of labour and delivery. Additional specifications have been included for “Early pregnancy loss”. A new section Obstetric haemorrhage has been added to enable all types of haemorrhage to be grouped together.

**Table 1: Comparison of ICD-10 block structure with ICD-11 equivalent structure**

**ICD-10 block heading**

O00-O08 Pregnancy with abortive outcome

O10-O16 Oedema, proteinuria and hypertensive disorders in pregnancy, childbirth and the puerperium

O20-O29 Other maternal disorders predominantly related to pregnancy

O30-O48 Maternal care related to the fetus and amniotic cavity and possible delivery problems

O60-O75 Complications of labour and delivery

O80-O84 Delivery

O85-O92 Complications predominantly related to the puerperium

O94-O99 Other obstetric conditions, not elsewhere classified

**ICD-11 equivalent structure**

Abortive outcome of pregnancy

Oedema, proteinuria, or hypertensive disorders in pregnancy, childbirth, or the puerperium

Certain specified maternal disorders predominantly related to pregnancy

Maternal care related to the fetus, amniotic cavity or possible delivery problems

Complications of labour or delivery

Delivery

Complications predominantly related to the puerperium

Certain obstetric conditions, not elsewhere classified

**3.15.19 Differences between ICD-10 and ICD-11 in Chapter 19**

There has been some reordering of this chapter but it remains similar to that in ICD-10. There is new grouping for Neurological disorders specific to the perinatal or neonatal period and an expansion of codes for gestational age of the newborn.

**Table 1: Comparison of ICD-10 block structure with ICD-11 equivalent structure**

<b>ICD-10 block heading</b>	<b>ICD-11 equivalent structure</b>
P00-P04 Fetus and newborn affected by maternal factors and by complications of pregnancy, labour and delivery	fetus or newborn affected by maternal factors or by complications of pregnancy, labour or delivery
P05-P08 Disorders related to length of gestation and fetal growth	Disorders of newborn related to length of gestation or fetal growth
P10-P15 Birth trauma	Birth injury
P20-P29 Respiratory and cardiovascular disorders specific to the perinatal period	Split into two groups: Respiratory disorders specific to the perinatal or neonatal period; Cardiovascular disorders present in the perinatal or neonatal period
P35-P39 Infections specific to the perinatal period	Infections of the fetus or newborn
P50-P61 Haemorrhagic and haematological disorders of fetus and newborn	Haemorrhagic or haematological disorders of fetus or newborn
P70-P74 Transitory endocrine and metabolic disorders specific to fetus and newborn	Transitory endocrine or metabolic disorders specific to fetus or newborn
P75-P78 Digestive system disorders of fetus and newborn	Digestive system disorders of fetus or newborn
P80-P83 Conditions involving the integument and temperature regulation of fetus and newborn	Split into two groups: Disorders involving the integument of fetus or newborn; Disturbances of temperature regulation of newborn
P90-P96 other disorders originating in the perinatal period	Certain disorders originating in the perinatal period – Block 91 other disturbances of cerebral status of newborn has been moved into a new grouping Neurological disorders specific to the perinatal or neonatal period

### 3.15.20 Differences between ICD-10 and ICD-11 in Chapter 20

This chapter has undergone major restructuring including a title change from Congenital malformations, deformations and chromosomal abnormalities to Developmental anomalies. All genetic syndromes without structural developmental anomalies have been reallocated to appropriate chapters of the ICD, according to the affected body system(s).

**Table 1: Comparison of ICD-10 block structure with ICD-11 equivalent structure**

**ICD-10 previous location**

Q00-Q07 Congenital malformations of the nervous system

Q10-Q18 Congenital malformations of eye, ear, face and neck

Q20-Q28 Congenital malformations of the circulatory system

Q30-Q34 Congenital malformations of the respiratory system

Q35-Q37 Cleft lip and cleft palate

Q38-Q45 Other congenital malformations of the digestive system

Q50-Q56 Congenital malformations of genital organs

Q60-Q64 Congenital malformations of the urinary system

Q65-Q79 Congenital malformations and deformations of the musculoskeletal system

Q80-Q89 Other congenital malformations

Q90-Q99 Chromosomal abnormalities, not elsewhere classified

**ICD-11 equivalent structure**

Structural developmental anomalies of the nervous system - A grouping under Structural developmental anomalies primarily affecting one body system

Split into four separate groups under Structural developmental anomalies primarily affecting one body system:

Structural developmental anomalies of the eye, eyelid or lacrimal apparatus

Structural developmental anomalies of the ear

Structural developmental anomalies of the face, mouth or teeth

Structural developmental anomalies of the neck

Structural developmental anomalies of the circulatory system - A grouping under Structural developmental anomalies primarily affecting one body system

Structural developmental anomalies of the respiratory system - A grouping under Structural developmental anomalies primarily affecting one body system

Clefts of lip, alveolus or palate is a subsection in the grouping Structural developmental anomalies of the face, mouth or teeth

Structural developmental anomalies of the digestive tract - A grouping under Structural developmental anomalies primarily affecting one body system

Split into two separate groups under Structural developmental anomalies primarily affecting one body system: Structural developmental anomalies of the female genital system; Structural developmental anomalies of the male genital system

Structural developmental anomalies of the urinary system - A grouping under Structural developmental anomalies primarily affecting one body system

Structural developmental anomalies of the skeleton

Redistributed to various groupings within the new structure of the chapter

Chromosomal anomalies, excluding gene mutations

### 3.15.21 Differences between ICD-10 and ICD-11 in Chapter 21

This chapter has undergone major restructuring with the high level hierarchy now in line with the ICD chapters. Certain clinical forms previously located in other chapters as asterisk codes are now located here. A new category has been added for Findings of microorganism resistant to antimicrobial drugs.

**Table 1: Comparison of ICD-10 block structure with ICD-11 equivalent structure**

### **ICD-10 block heading**

R00-R09 Symptoms and signs involving the circulatory and respiratory systems

R10-R19 Symptoms and signs involving the digestive system and abdomen

R20-R23 Symptoms and signs involving the skin and subcutaneous tissue

R25-R29 Symptoms and signs involving the nervous and musculoskeletal systems

R30-R39 Symptoms and signs involving the urinary system

R40-R46 Symptoms and signs involving cognition, perception, emotional state and behaviour

R47-R49 Symptoms and signs involving speech and voice

R50-R69 General symptoms and signs

R70-R79 Abnormal findings on examination of blood, without diagnosis

R80-R82 Abnormal findings on examination of urine, without diagnosis

R83-R89 Abnormal findings on examination of other body fluids, substances and tissues, without diagnosis

R90-R94 Abnormal findings on diagnostic imaging and in function studies, without diagnosis

R95-R99 Ill-defined and unknown causes of mortality

### **ICD-11 equivalent structure**

Split into two groupings: Symptoms, signs or clinical findings of the circulatory system; Symptoms, signs or clinical findings of the respiratory system

Symptoms, signs or clinical findings of the digestive system or abdomen

Symptoms, signs or clinical findings involving the skin

Split into two groupings: Symptoms, signs or clinical findings of the nervous system; Symptoms, signs or clinical findings of the musculoskeletal system

Symptoms, signs or clinical findings of the genitourinary system - part of the grouping Symptoms, signs or clinical findings of the genitourinary system

Reorganised into various subsections under Mental or behavioural symptoms, signs or clinical findings

Symptoms, signs or clinical findings of speech or voice

General symptoms, signs or clinical findings

Included in the grouping Symptoms, signs or clinical findings of blood, blood-forming organs or the immune system

Clinical findings on examination of urine, without diagnosis under the grouping Symptoms, signs or clinical findings involving the urinary system

Clinical findings in specimens from other specified organs, systems and tissues under the grouping General symptoms, signs or clinical findings

Split into two subsections: Abnormal diagnostic imaging results not elsewhere classified; Abnormal results of function studies of other organs and systems in the grouping Abnormal results not elsewhere classified

Ill-defined and unknown causes of mortality

## **3.15.22 Differences between ICD-10 and ICD-11 in Chapter 22**

The high level categories have only a few changes. Changes are mainly at the lower character level and include additions of more specific categories of injury types and body location of the injury. There are no longer separate codes for burns and for corrosions. They are all together under Burns. Additional dimensions are available from Chapter X Extension codes, for postcoordination to add further detail such as laterality, or depth of burn. Major changes have been made to the section for complications of medical and surgical care. The Quality and Safety TAG has revised the coding of health care related injuries and events. The concept of a mechanical complication of a device is now classified as an external cause of harm.

**Table 1: Comparison of ICD-10 block structure with ICD-11 equivalent structure**

<b>ICD-10 block heading</b>	<b>ICD-11 equivalent structure</b>
S00-S09 Injuries to the head	Injuries to the head
S10-S19 Injuries to the neck	Injuries to the neck
S20-S29 Injuries to the thorax	Injuries to the thorax
S30-S39 Injuries to the abdomen, lower back, lumbar spine and pelvis	Injuries to the abdomen, lower back, lumbar spine or pelvis
S40-S49 Injuries to the shoulder and upper arm	Injuries to the shoulder or upper arm
S50-S59 Injuries to the elbow and forearm	Injuries to the elbow or forearm
S60-S69 Injuries to the wrist and hand	Injuries to the wrist or hand
S70-S79 Injuries to the hip and thigh	Injuries to the hip or thigh
S80-S89 Injuries to the knee and lower leg	Injuries to the knee or lower leg
S90-S99 Injuries to the ankle and foot	Injuries to the ankle or foot
T00-T07 Injuries involving multiple body regions	Injuries involving multiple body regions
T08-T14 Injuries to unspecified part of trunk, limb or body region	Injuries to unspecified part of trunk, limb or body region
T15-T19 Effects of foreign body entering through natural orifice	Effects of foreign body entering through natural orifice
T20-T32 Burns and corrosions	Burns
T33-T35 Frostbite	Frostbite
T36-T50 Poisoning by drugs, medicaments and biological substances	Now included under the main grouping Harmful effects of substances
T51-T65 Toxic effects of substances chiefly nonmedicinal as to source	Now included under the main grouping Harmful effects of substances
T66-T78 Other and unspecified effects of external causes	Other or unspecified effects of external causes
T79 Certain early complications of trauma	Other or unspecified effects of external causes
	Now included under the main grouping



**ICD-10 block heading**

T80-T88 Complications of surgical and medical care, not elsewhere classified

T90-T98 Sequelae of injuries, of poisoning and of other consequences of external causes

**ICD-11 equivalent structure**

Injury or harm arising from surgical or medical care, not elsewhere classified

Redistributed to the specific body grouping as index terms. Sequelae will now be indicated by an cluster identifying the condition that is the sequelae, a code from Chapter 24 [QC50](#) and the original injury.

**3.15.23 Differences between ICD-10 and ICD-11 in Chapter 23**

The primary axis for all external causes except exposure to extreme forces of nature, maltreatment, legal intervention, armed conflict and health care related harm or injury is now based on 'intent'. The codes are a combination of intent, followed by mechanism and object or substance involved in occurrence of injury. There has been an expansion in the areas of vehicle types, places of occurrence, types of activities, legal/war codes, and substances. The areas of Complications of medical and surgical care and Maltreatment syndromes have been revised and improved. Additional dimensions are available from Chapter X Extension codes, for use in postcoordination. Further, the categories for sequelae of external causes have been removed and such cases are primarily coded to the appropriate categories describing the event, resulting in increases in the frequencies of the specific categories.

An extension code can be used in postcoordination where such sequelae need to be identified separately.

**Table 1: Comparison of ICD-10 block structure with ICD-11 equivalent structure**

<b>ICD-10 block heading</b>	<b>ICD-11 equivalent structure</b>
V01-X59 Accidents	Redistributed to the main groupings of Unintentional cause, Intentional self-harm, Assault and Unknown intent
X60-X84 Intentional self-harm	Intentional self-harm
X85-Y09 Assault	Assault
Y10-Y34 Event of undetermined intent	Undetermined intent
Y35-Y36 Legal intervention and operations of war	Split into two groups: Legal intervention; Armed conflict
Y40-Y84 Complications of medical and surgical care	Causes of health care related harm or injury
Y85-Y89 Sequelae of external causes of morbidity and mortality	Redistributed to the specific external cause grouping as index terms. Sequelae will now be indicated by a cluster identifying the condition that is the sequelae, a code from Chapter 24 <a href="#">QC50</a> and the original external cause code.
Y90-Y98 Supplementary factors related to causes of morbidity and mortality classified elsewhere	Entities from this block are now found in either Chapter 21 Symptoms, signs and clinical findings (e.g. blood alcohol level findings) or have been added to Section X 'Extension codes' (e.g. nosocomial condition)

### 3.15.24 Differences between ICD-10 and ICD-11 in Chapter 24

This chapter has undergone reorganisation and is divided into two main sections: Reasons for contact with the health system and Factors influencing health status. There has been an expansion of the section related to reproduction with the addition of a new section Contact with health services for reproductive management. There is also a new section for health care related adverse events that occur but do not result in any harm to the patient.

**Table 1: Comparison of ICD-10 block structure with ICD-11 equivalent structure**

**ICD-10 block heading**

Z00-Z13 Persons encountering health services for examination and investigation

Z20-Z29 Persons with potential health hazards related to communicable diseases

Z30-Z39 Persons encountering health services in circumstances related to reproduction

Z40-Z54 Persons encountering health services for specific procedures and health care

Z55-Z65 Persons with potential health hazards related to socioeconomic and psychosocial circumstances

Z70-Z76 Persons encountering health services in other circumstances

Z80-Z99 Persons with potential health hazards related to family and personal history and certain conditions influencing health status

**ICD-11 equivalent structure**

Contact with health systems for purposes of examination or investigation – a section under the grouping Reasons for contact with the health system

Contact with or exposure to communicable diseases – a section under the grouping Reasons for contact with the health system

Contact with health services for reasons associated with reproduction diseases – a section under the grouping Reasons for contact with the health system

Split into two new sections, under Reasons for contact with the health system: Contact with health services for specific surgical interventions; Contact with health services for nonsurgical interventions not involving devices

Reorganised and now appear under main grouping of Factors influencing health status

Reorganised and now appear under main grouping of Factors influencing health status

Reorganised and now appear under main grouping of Factors influencing health status

### 3.15.25 Differences between ICD-10 and ICD-11 in Chapter 25

Diseases formerly coded here have been moved to their primary places within ICD-11. New codes for use as international provisional codes have been included.

**Table 1: Comparison of ICD-10 block structure with ICD-11 equivalent structure**

### ICD-10 block heading

U00-U49 Provisional assignment of new diseases of uncertain aetiology or emergency use

U82-U85 Resistance to antimicrobial and antineoplastic drugs

### ICD-11 equivalent structure

Split into two new sections: International provisional assignment of new diseases of uncertain aetiology; National provisional assignment of new diseases of uncertain aetiology

Moved to Chapter 21 with the new title Finding of microorganism resistant to antimicrobial drugs

## 3.16 Annex E: Referred Value Sets

- Section [2.19.1.8 Hypertension due to other conditions](#) refers to 3 Value Sets:
  - [Endocrine neoplasms](#)
  - [Renal neoplasms](#)
  - [Carcinoid tumours](#)
- Section [2.19.2.3 Sepsis](#) refers to 6 Value Sets:
  - [Conditions that impair the immune system](#)
  - [Wasting Diseases](#)
  - [Diseases causing paralysis - sepsis](#)
  - [Serious respiratory conditions](#)
  - [Serious injuries](#)
  - [Diseases of infectious origin](#)
- Section [2.19.2.9 Embolism](#) refers to 6 Value Sets:
  - [Venous thrombosis](#)
  - [Phlebitis or thrombophlebitis](#)
  - [Valvular heart disease](#)
  - [Childbirth](#)
  - [Operation](#)
  - [Embolism](#)
- Section [2.19.2.11 Pneumonia](#) refers to 6 Value Sets:
  - [Conditions that impair the immune system](#)
  - [Wasting Diseases](#)
  - [Diseases causing paralysis](#)
  - [Serious respiratory conditions](#)
  - [Conditions that affect the process of swallowing](#)
  - [Serious injuries](#)
- Section [2.19.2.21 Common secondary conditions](#) refers to 3 Value Sets:
  - [Wasting Diseases](#)
  - [Diseases causing paralysis](#)

## Serious injuries

- Section [2.19.2.22 Secondary peritonitis](#) refers to 1 Value Set:  
[Secondary peritonitis and unspecified peritonitis](#)
- Section [3.14.10 List of conditions unlikely to cause death](#) refers to 1 Value Set:  
[Unlikely to cause death](#)
- Section [3.14.14 Target list of causes of death for verbal autopsy](#) refers to 65 Value Sets:  
[Sepsis](#)  
[Acute respiratory infection, including pneumonia](#)  
[HIV/AIDS related death](#)  
[Diarrheal diseases](#)  
[Malaria](#)  
[Measles](#)  
[Meningitis and encephalitis](#)  
[Tetanus](#)  
[Pulmonary tuberculosis](#)  
[Pertussis](#)  
[Haemorrhagic fever](#)  
[Dengue fever](#)  
[Coronavirus disease \(COVID-19\)](#)  
[Unspecified infectious disease](#)  
[Other and unspecified non-communicable disease](#)  
[Oral neoplasms](#)  
[Digestive neoplasms](#)  
[Respiratory neoplasms](#)  
[Breast neoplasms](#)  
[Female reproductive neoplasms](#)  
[Male reproductive neoplasms](#)  
[Other and unspecified neoplasms](#)  
[Severe anaemia](#)  
[Severe malnutrition](#)  
[Diabetes mellitus](#)  
[Acute cardiac disease](#)  
[Stroke](#)  
[Sickle cell with crisis](#)  
[Other and unspecified cardiac disease](#)  
[Chronic obstructive pulmonary disease \(COPD\)](#)  
[Asthma](#)  
[Acute abdomen](#)  
[Liver cirrhosis](#)  
[Renal failure](#)  
[Epilepsy](#)  
[Ectopic pregnancy](#)  
[Abortion-related death](#)

[Pregnancy-induced hypertension](#)  
[Obstetric haemorrhage](#)  
[Obstructed labour](#)  
[Pregnancy-related sepsis](#)  
[Anaemia of pregnancy](#)  
[Ruptured uterus](#)  
[Other and unspecified maternal cause](#)  
[Prematurity or low birth weight](#)  
[Birth asphyxia](#)  
[Neonatal pneumonia](#)  
[Neonatal sepsis](#)  
[Neonatal tetanus](#)  
[Congenital malformation](#)  
[Other and unspecified perinatal cause of death](#)  
[Fresh stillbirth](#)  
[Macerated stillbirth](#)  
[Road traffic accident](#)  
[Other transport accident](#)  
[Accidental fall](#)  
[Accidental drowning and submersion](#)  
[Accidental exposure to smoke, fire and flames](#)  
[Contact with venomous animals and plants](#)  
[Accidental poisoning and exposure to noxious substance](#)  
[Intentional self-harm](#)  
[Assault](#)  
[Exposure to force of nature](#)  
[Other and unspecified external cause of death](#)  
[Cause of death unknown](#)